

## FEATURES

- Output voltage: 3.3V, 5V, 12V and adjustable output version
- Adjustable version output voltage range, 1.23V to 18V+4%
- 150KHz +15% fixed switching frequency
- Voltage mode non-synchronous PWM control
- Thermal-shutdown and current-limit protection
- ON/OFF shutdown control input
- Operating voltage can be up to 26V
- Output load current: 2A
- SOP-8L packages
- Low power standby mode
- Built-in switching transistor on chip
- Moisture Sensitivity Level 3

## APPLICATIONS

- Simple High-efficiency step-down regulator
- On-card switching regulators
- Positive to negative converter
- Negative Step-Up Converters
- Power Supply for Battery Chargers

## DESCRIPTION

The TJ1509A series are monolithic IC designed for a step-down DC/DC converter, and own the ability of driving a 2A load without additional transistor component. Due to reducing the number of external component, the board space can be saved easily. The external shutdown function can be controlled by logic level and then come into standby mode.

The internal compensation makes feedback control have good line and load regulation without external design. Regarding protected function, thermal shutdown is to prevent over temperature operating from damage, and current limit is against over current operating of the output switch. If current limit function occurred and VFB is down to 0.5V below, the switching frequency will be reduced.

The TJ1509A series operates at a switching frequency of 150KHz thus allowing smaller sized filter components than what would be needed with lower frequency switching regulators. Other features include a guaranteed +4% tolerance on output voltage under specified input voltage and output load conditions, and +15% on the oscillator frequency.

The output version included fixed 3.3V, 5V, 12V, and an adjustable type.

The packages are available in a standard 8-lead SOP-8 package.

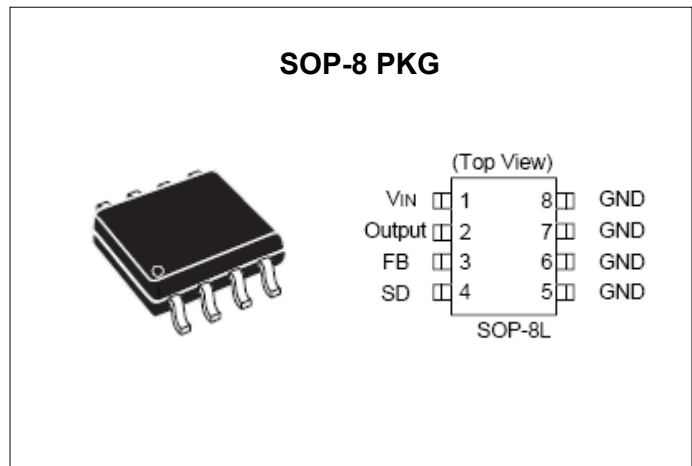

## PIN DESCRIPTION

Pin No	Function	Description
1	Vin	Operating voltage input
2	Vout	Switching output
3	FB	Output voltage feedback control
4	SD	ON/OFF Shutdown
5~8	Ground	Ground

## ORDERING INFORMATION

Device	Marking	Package
TJ1509A-ADJ	TJ1509A ADJ	SOP-8
TJ1509A-3.3	TJ1509A 3.3	
TJ1509A-5.0	TJ1509A 5.0	
TJ1509A-12	TJ1509A 12	

Typical Application Circuit

(1) Fixed Type Circuit

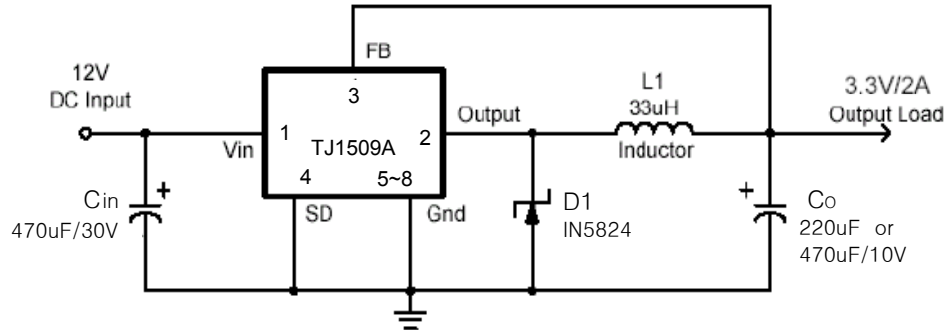

(2) Adjustable Type Circuit

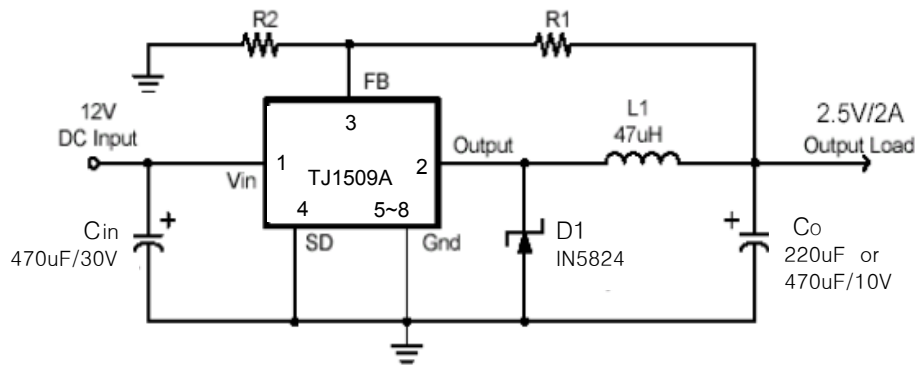

$$V_{out} = V_{FB} \times \left(1 + \frac{R1}{R2}\right)$$

$$V_{FB} = 1.23V$$

$$R2 = 1K \sim 3K$$

(3) Delay Start Circuit

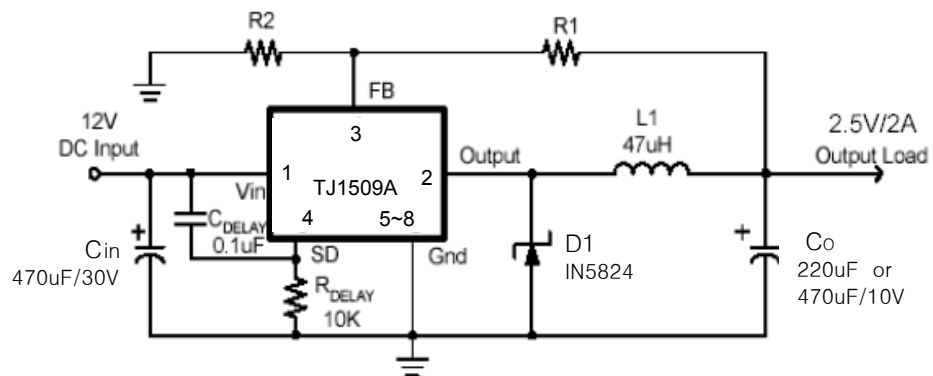

BLOCK DIAGRAM

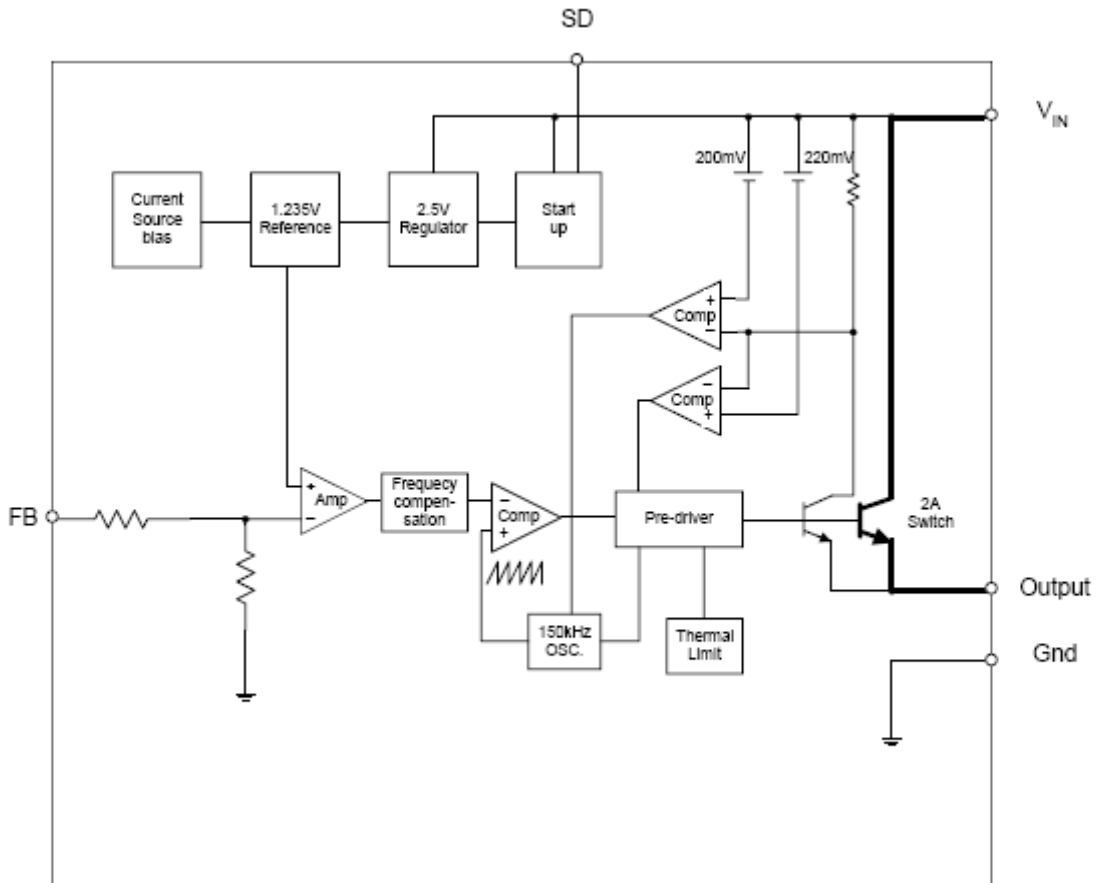

ABSOLUTE MAXIMUM RATINGS

SYMBOL	PARAMETER	RATING	UNIT
$V_{CC}$	Supply Voltage	30	V
$V_{SD}$	SD Pin Input Voltage	-0.3 to +18	V
$V_{FB}$	Feedback Pin Voltage	-0.3 to +18	V
$V_{OUT}$	Output Voltage to Ground	-1	V
$P_D$	Power Dissipation	Internally limited	W
$T_{ST}$	Storage Temperature	-65 to +150	°C
$T_{OP}$	Operating Temperature	-40 to +125	°C
$V_{OP}$	Operating Voltage	+4.5 to +22	V

**ELECTRICAL CHARACTERISTICS (All Output Voltage Versions)**

Unless otherwise specified,  $V_{IN}=12V$  for 3.3V, 5V, adjustable version and  $V_{IN}=18V$  for the 12V version.  $I_{LOAD} = 0.5A$

SYMBOL	PARAMETER		CONDITIONS	MIN.	TYP.	MAX.	UNIT
$I_{FB}$	Feedback Bias Current		$V_{FB}=1.3V$ (Adjustable version only)		-10	-50 -100	nA
$F_{OSC}$	Oscillator Frequency			127 <b>110</b>	150	173 <b>173</b>	KHz
$F_{SCP}$	Oscillator Frequency of Short Circuit Protect		When current limit occurred and $V_{FB} < 0.5V$ , $T_a=25^\circ C$	10	30	50	KHz
$V_{SAT}$	Saturation Voltage		$I_{OUT}=2A$ No outside circuit $V_{FB}=0V$ force driver on		1.25	1.4 <b>1.5</b>	V
DC	Max. Duty Cycle (ON)		$V_{FB}=0V$ force driver on		100		%
	Min. Duty Cycle (OFF)		$V_{FB}=12V$ force driver off		0		
$I_{CL}$	Current Limit		Peak current No outside circuit $V_{FB}=0$ force driver on	3			A
$I_L$	Output = 0V	Output Leakage Current	No outside circuit $V_{FB}=12$ force driver off			-200	$\mu A$
	Output = -1V		$V_{IN}=22V$		-5		mA
$I_Q$	Quiescent Current		$V_{FB}=12$ force driver off		5	10	mA
$I_{STBY}$	Standby Quiescent Current		SD pin=5V $V_{IN}=22V$		70	150 <b>200</b>	$\mu A$
$V_{IL}$	SD Pin Logic Input Threshold Voltage		Low (regulator ON)	-	1.3	0.6	V
$V_{IH}$			High (regulator OFF)	2.0		-	
$I_H$	SD Pin Logic Input Current		$V_{LOGIC}=2.5V$ (OFF)			-0.01	$\mu A$
$I_L$	SD Pin Input Current		$V_{LOGIC}=0.5V$ (ON)		-0.1	-1	
$\theta_{JC}$	Thermal Resistance		SOP-8L	Junction to case		15	$^\circ C / W$
$\theta_{JA}$	Thermal Resistance With copper area of approximately 3 in <sup>2</sup>		SOP-8L	Junction to ambient		70	$^\circ C / W$

Specifications with boldface type are for full operating temperature range, the other type are for  $T_J=25^\circ C$ .

**ELECTRICAL CHARACTERISTICS (Continued)**

	SYMBOL	PARAMETER	CONDITIONS	TYP.	LIMIT	UNIT
TJ1509A -ADJ	$V_{FB}$	Output Feedback	$4.5V \leq V_{IN} \leq 22V$ $0.2A \leq I_{LOAD} \leq 2A$ $V_{OUT}$ programmed for 3V	1.23	1.193/ <b>1.18</b> 1.267/ <b>1.28</b>	V $V_{MIN}$ $V_{MAX}$
	$\eta$	Efficiency	$V_{IN} = 12V, I_{LOAD}=2A$	76		%
TJ1509A -3.3V	$V_{OUT}$	Output voltage	$4.75V \leq V_{IN} \leq 22V$ $0.2A \leq I_{LOAD} \leq 2A$	3.3	3.168/ <b>3.135</b> 3.432/ <b>3.465</b>	V $V_{MIN}$ $V_{MAX}$
	$\eta$	Efficiency	$V_{IN} = 12V, I_{LOAD}=2A$	78		%
TJ1509A -5.0V	$V_{OUT}$	Output voltage	$7V \leq V_{IN} \leq 22V$ $0.2A \leq I_{LOAD} \leq 2A$	5	4.8/ <b>4.75</b> 5.2/ <b>5.25</b>	V $V_{MIN}$ $V_{MAX}$
	$\eta$	Efficiency	$V_{IN} = 12V, I_{LOAD}=2A$	83		%
TJ1509A -12V	$V_{OUT}$	Output voltage	$15V \leq V_{IN} \leq 22V$ $0.2A \leq I_{LOAD} \leq 2A$	12	11.52/ <b>11.4</b> 12.48/ <b>12.6</b>	V $V_{MIN}$ $V_{MAX}$
	$\eta$	Efficiency	$V_{IN} = 15V, I_{LOAD} = 2A$	90		%

Specifications with boldface type are for full operating temperature range, the other type are for  $T_J=25^\circ C$ .

TYPICAL PERFORMANCE CHARACTERISTICS

TJ1509A Output Voltage vs. Output Current  
(Vin=12V, Vout=5V, Io=2A)

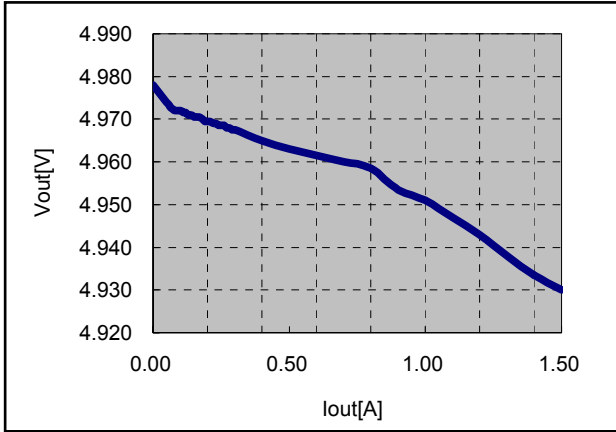

TJ1509A Efficiency vs. Output Current  
(Vin=12V, Vout=5V, Io=2A)

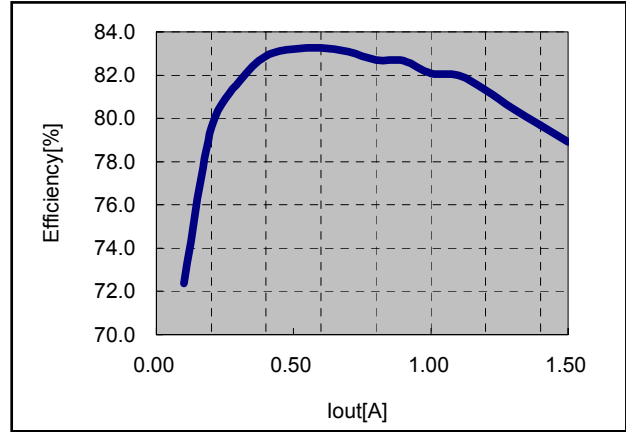

TJ1509A Output Voltage vs. Output Current  
(Vin=15V, Vout=5V, Io=2A)

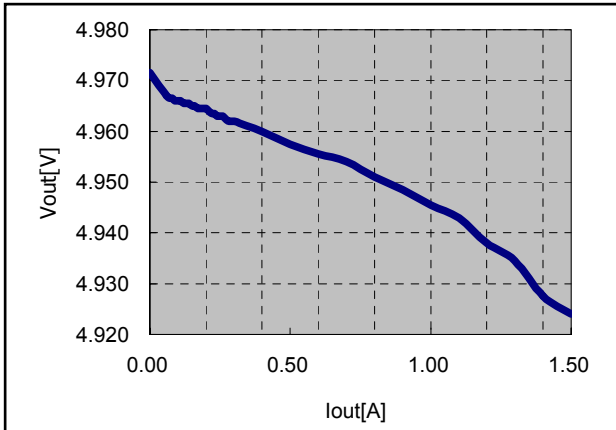

TJ1509A Efficiency vs. Output Current  
(Vin=15V, Vout=5V, Io=2A)

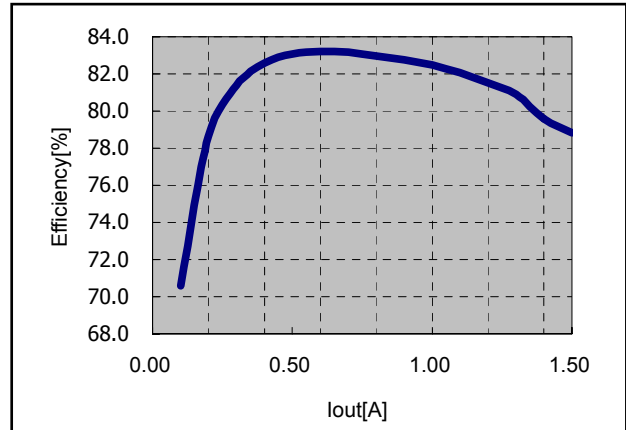

TJ1509A Input Current vs. Input Voltage  
(Io=0A)

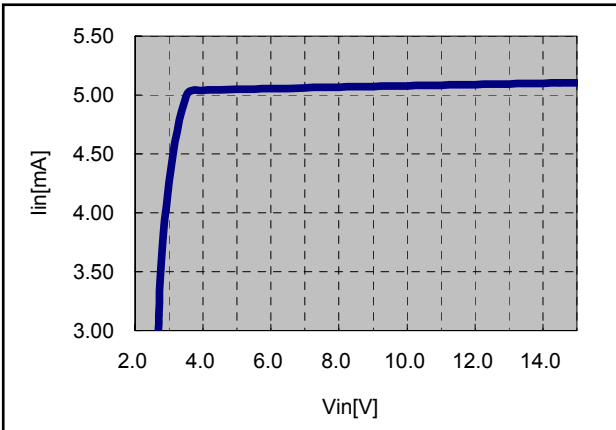

TJ1509A Feedback Voltage vs. Temperature  
(Vin=12V, Vout=5V)

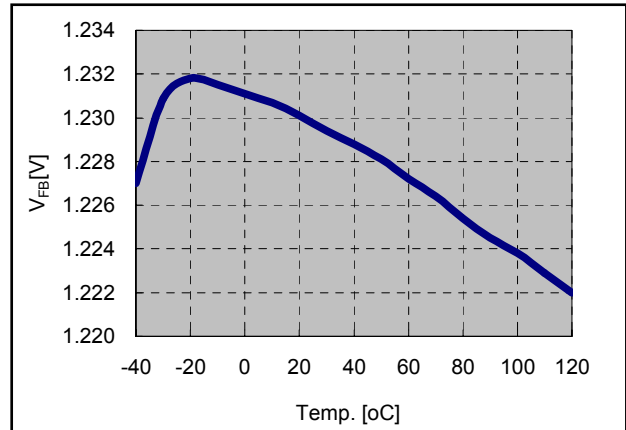

TYPICAL PERFORMANCE CHARACTERISTICS

TJ1509A Efficiency vs. Temperature

( $V_{in}=12V$ ,  $V_{out}=5V$ ,  $I_o=2A$ )

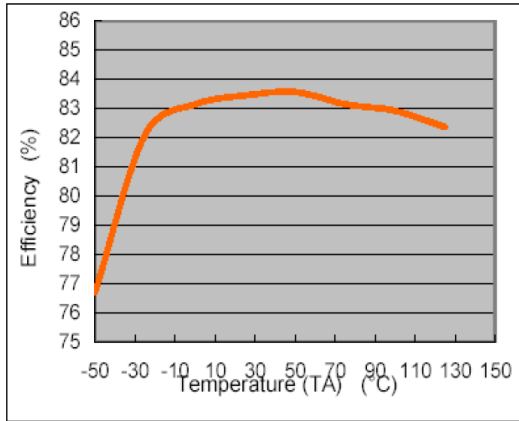

TJ1509A Efficiency vs. Temperature

( $V_{in}=12V$ ,  $V_{out}=3.3V$ ,  $I_o=2A$ )

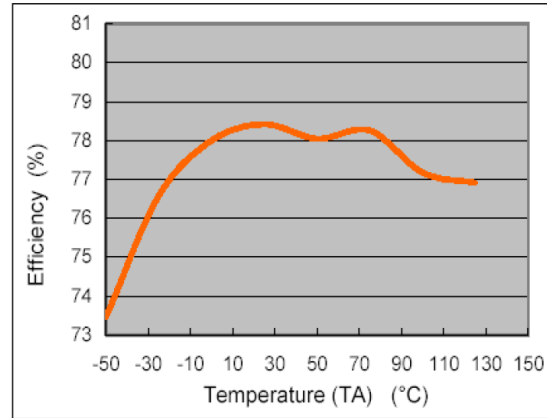

TJ1509A Saturation Voltage vs. Temperature

( $V_{cc}=12V$ ,  $V_{fb}=0V$ ,  $V_{SD}=0$ )

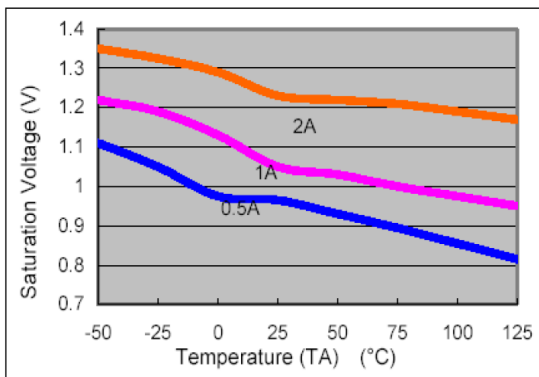

TJ1509A Switch Current Limit vs. Temperature

( $V_{cc}=12V$ ,  $V_{fb}=0V$ )

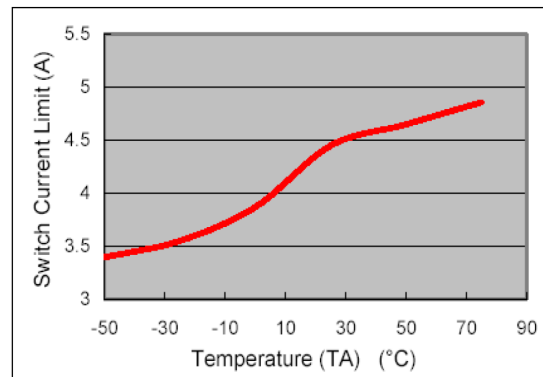

TJ1509A Supply Current vs. Temperature

( $V_{cc}=12V$ , No Load,  $V_{on/off}=0V$ (Switch ON),  $V_{on/off}=5V$ (Switch OFF))

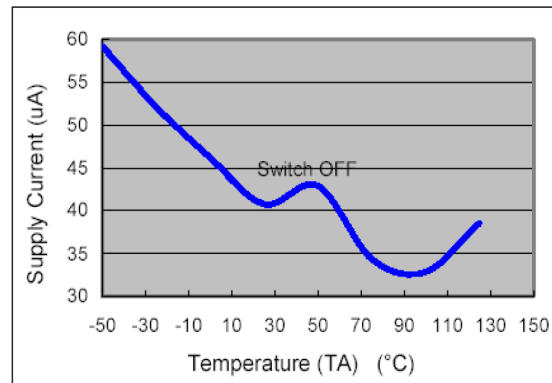
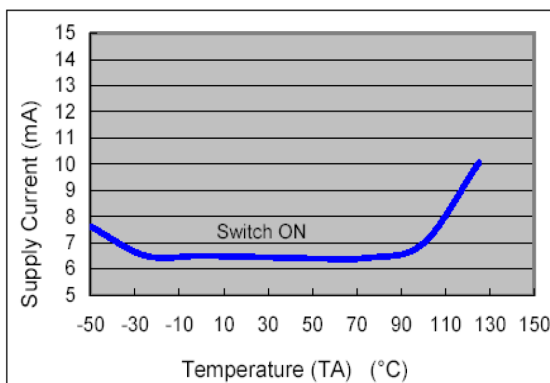

TYPICAL PERFORMANCE CHARACTERISTICS

TJ1509A Threshold Voltage vs. Temperature  
(V<sub>cc</sub>=12V, I<sub>o</sub>=100mA)

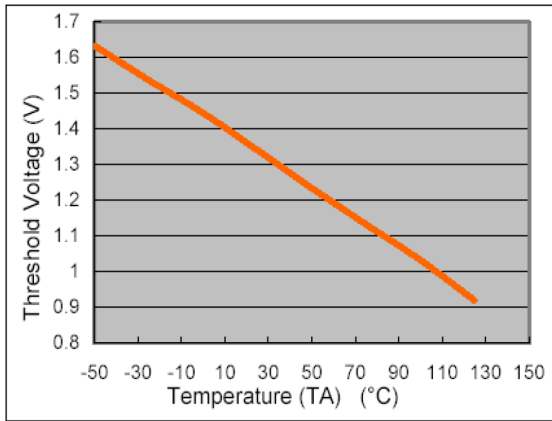

TJ1509A ON/OFF Current vs. ON/OFF Voltage  
(V<sub>in</sub>=12V)

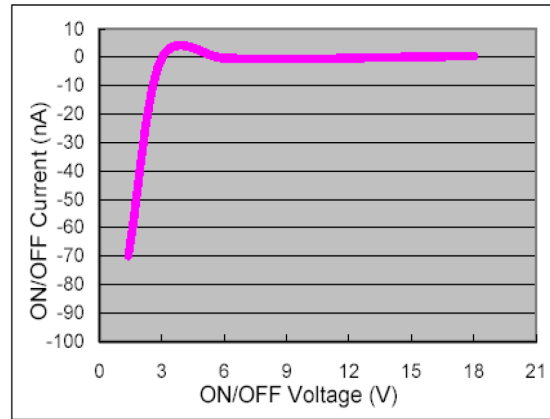

TJ1509A Frequency vs. Temperature  
(V<sub>cc</sub>=12V, I<sub>o</sub>=500mA, V<sub>out</sub>=5V)

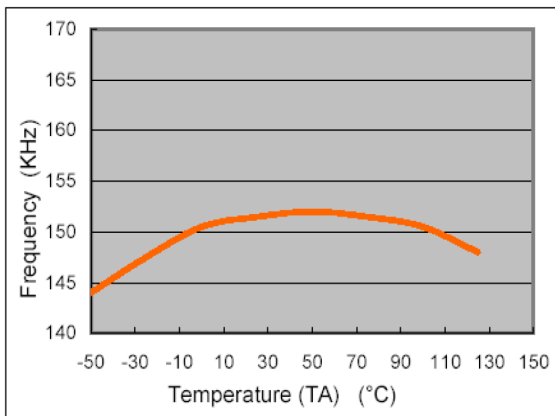

TJ1509A Feedback Current vs. Temperature  
(V<sub>cc</sub>=12V, V<sub>out</sub>=5V, V<sub>fb</sub>=1.3V)

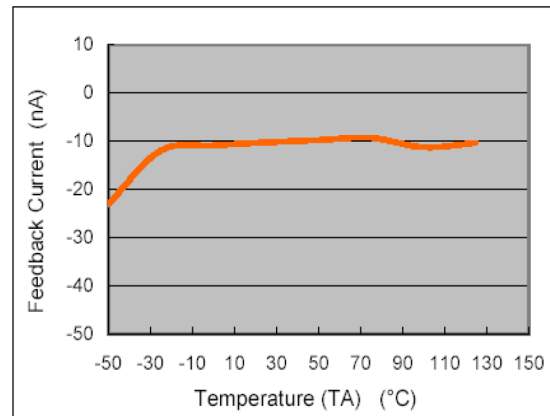

TJ1509A Output Voltage vs. Temperature  
(V<sub>in</sub>=12V, I<sub>o</sub>=2A)

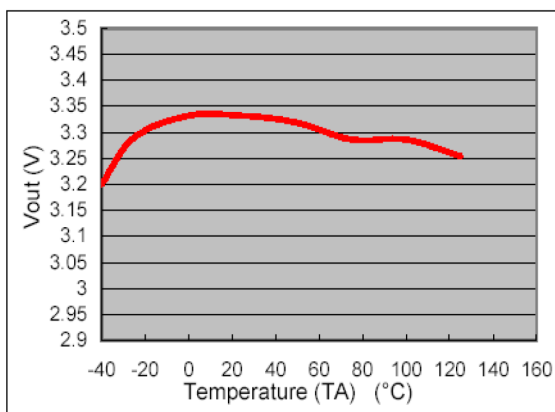

**FUNCTION DESCRIPTION****Pin Functions****+VIN**

This is the positive input supply for the IC switching regulator. A suitable input bypass capacitor must be present at this pin to minimize voltage transients and to supply the switching currents needed by the regulator.

**Ground**

Circuit ground.

**Output**

Internal switch. The voltage at this pin switches between (+VIN – VSAT) and approximately – 0.5V, with a duty cycle of approximately VOUT / VIN. To minimize coupling to sensitive circuitry, the PC board copper area connected to this pin should be kept a minimum.

**Feedback(FB)**

Senses the regulated output voltage to complete the feedback loop.

**ON/OFF (SD)**

Allows the switching regulator circuit to be shutdown using logic level signals thus dropping the total input supply current to approximately 150uA. Pulling this pin below a threshold voltage of approximately 1.3V turns the regulator on, and pulling this pin above 1.3V (up to a maximum of 18V) shuts the regulator down. If this shutdown feature is not needed, the SD pin can be wired to the ground pin or it can be left open, in either case the regulator will be in the ON condition.

**Thermal Considerations**

The SOP-8 package needs a heat sink under most conditions. The size of the heatsink depends on the input voltage, the output voltage, the load current and the ambient temperature. The TJ1509A junction temperature rises above ambient temperature for a 3A load and different input and output voltages. The data for these curves was taken with the TJ1509A (SOP-8 package) operating as a buck-switching regulator in an ambient temperature of 25 °C (still air). These temperature rise numbers are all approximate and there are many factors that can affect these temperatures. Higher ambient temperatures require more heat sinking.

For the best thermal performance, wide copper traces and generous amounts of printed circuit board copper should be used in the board layout. [Once exception to this is the output (switch) pin, which should not have large areas of copper.] Large areas of copper provide the best transfer of heat (lower thermal resistance) to the surrounding air, and moving air lowers the thermal resistance even further.

Package thermal resistance and junction temperature rise numbers are all approximate, and there are many factors that will affect these numbers. Some of these factors include board size, shape, thickness, position, location, and even board temperature. Other factors are, trace width, total printed circuit copper area, copper thickness, single or double-sided, multi-layer board and the amount of solder on the board.

The effectiveness of the PC board to dissipate heat also depends on the size, quantity and spacing of other components on the board, as well as whether the surrounding air is still or moving. Furthermore, some of these components such as the catch diode will add heat to the PC board and the heat can vary as the input voltage changes. For the inductor, depending on the physical size, type of core material and the DC resistance, it could either act as a heat sink taking heat away from the board, or it could add heat to the board.