

EXAMINED BY :	EMERGING DISPLAY TECHNOLOGIES CORPORATION	FILE NO . CAS-0008341
Lucica Lu		ISSUE : OCT.05, 2017
APPROVED BY:		TOTAL PAGE : 23
Vincent Wh		VERSION : 3

CUSTOMER ACCEPTANCE SPECIFICATIONS

MODEL NO. :

ET101002DB6

(GP)

FOR MESSRS :

CUSTOMER'S APPROVAL

DATE :

BY :

RECORDS OF REVISION

DOC . FIRST ISSUE

AUG.29, 2016

DATE	REVISED PAGE NO.	SUMMARY																																																																																																																																																																																							
JAN.10, 2017	1	2. MECHANICAL SPECIFICATIONS (3)MODULE SIZE : 5.8D mm→9.3D (MAX.)																																																																																																																																																																																							
	4	4. ELECTRICAL CHARACTERISTICS MODIFY NOTE (4), (6)																																																																																																																																																																																							
	9	MODIFY 6.2 THE TEST METHOD OF BRIGHTNESS AND UNIFORMITY																																																																																																																																																																																							
	10	7. OUTLINE DIMENSIONS MARK△: MODIFY MODULE THICKNESS & B/L FPC, ADD PCB DIMENSION																																																																																																																																																																																							
OCT.05, 2017	2	3.1 ELECTRICAL ABSOLUTE MAXIMUM RATINGS LED BACKLIGHT POWER DISSIPATION : MAX.=(5.580)→18.36 LED BACKLIGHT FORWARD CURRENT : MAX.=(300)→900 LED BACKLIGHT REVERSE VOLTAGE : MAX.=(20.4)→7.2																																																																																																																																																																																							
	3	4. ELECTRICAL CHARACTERISTICS VDD CURRENT : TYP.=(200)→150, MAX.=(250)→190 POWER SUPPLY CURRENT FOR LED DRIVER : TYP.=(550)→500, MAX.=(650)→625 LED LIFE TIME : MIN.=(50K)→50K																																																																																																																																																																																							
	5 , 6	5. TIMING CHARACTERISTICS REVISING THE ENTIRE PAGE																																																																																																																																																																																							
	8	6.1 OPTICAL CHARACTERISTICS <table border="1" style="width:100%; border-collapse: collapse;"> <thead> <tr> <th>ITEM</th> <th>SYMBOL</th> <th>CONDITION</th> <th>MIN.</th> <th>TYP.</th> <th>MAX.</th> <th>UNIT</th> <th>REMARK</th> </tr> </thead> <tbody> <tr> <td rowspan="4">VIEWING ANGLE</td> <td>θ_{+}</td> <td rowspan="4">CR ≥ 10</td> <td rowspan="4">0x=0°</td> <td>(60)</td> <td>(70)</td> <td>—</td> <td rowspan="4">deg. NOTE (2) NOTE (3)</td> </tr> <tr> <td>θ_{-}</td> <td>(70)</td> <td>(80)</td> <td>—</td> </tr> <tr> <td>θ_{+}</td> <td>(70)</td> <td>(80)</td> <td>—</td> </tr> <tr> <td>θ_{-}</td> <td>(70)</td> <td>(80)</td> <td>—</td> </tr> <tr> <td>CONTRAST RATIO</td> <td>CR</td> <td>0x=0° , 0y=0°</td> <td>(400)</td> <td>(500)</td> <td>—</td> <td>—</td> <td>NOTE (3)</td> </tr> <tr> <td>RESPONSE TIME</td> <td>T_r (rise)+ T_f (fall)</td> <td>0x=0° , 0y=0°</td> <td>—</td> <td>(16)</td> <td>(32)</td> <td>msec</td> <td>NOTE (4)</td> </tr> <tr> <td rowspan="8">COLOR OF CIE COORDINATE</td> <td rowspan="2">WHITE</td> <td>W_x</td> <td rowspan="8">0x=0° , 0y=0° NTSC : 45% VLED-VSS=12.0V</td> <td>(0.25)</td> <td>(0.30)</td> <td>(0.35)</td> <td rowspan="8">—</td> <td rowspan="8">NOTE (6)</td> </tr> <tr> <td>W_y</td> <td>(0.32)</td> <td>(0.37)</td> <td>(0.42)</td> </tr> <tr> <td>RED</td> <td>R_x</td> <td>(0.555)</td> <td>(0.605)</td> <td>(0.655)</td> </tr> <tr> <td>R_y</td> <td>(0.277)</td> <td>(0.327)</td> <td>(0.377)</td> </tr> <tr> <td>GREEN</td> <td>G_x</td> <td>(0.236)</td> <td>(0.286)</td> <td>(0.336)</td> </tr> <tr> <td>G_y</td> <td>(0.476)</td> <td>(0.526)</td> <td>(0.576)</td> </tr> <tr> <td>BLUE</td> <td>B_x</td> <td>(0.10)</td> <td>(0.15)</td> <td>(0.20)</td> </tr> <tr> <td>B_y</td> <td>(0.095)</td> <td>(0.145)</td> <td>(0.195)</td> </tr> <tr> <td>THE BRIGHTNESS OF MODULE</td> <td>B</td> <td>0x=0° , 0y=0° VLED-VSS=12.0V</td> <td>(800)</td> <td>(1000)</td> <td>—</td> <td>cd/m²</td> <td>NOTE (5)</td> </tr> </tbody> </table> <table border="1" style="width:100%; border-collapse: collapse;"> <thead> <tr> <th>ITEM</th> <th>SYMBOL</th> <th>CONDITION</th> <th>MIN.</th> <th>TYP.</th> <th>MAX.</th> <th>UNIT</th> <th>REMARK</th> </tr> </thead> <tbody> <tr> <td rowspan="4">VIEWING ANGLE</td> <td>θ_{+}</td> <td rowspan="4">CR ≥ 10</td> <td rowspan="4">0x=0°</td> <td>60</td> <td>70</td> <td>—</td> <td rowspan="4">deg. NOTE (2) NOTE (3)</td> </tr> <tr> <td>θ_{-}</td> <td>70</td> <td>80</td> <td>—</td> </tr> <tr> <td>θ_{+}</td> <td>70</td> <td>80</td> <td>—</td> </tr> <tr> <td>θ_{-}</td> <td>70</td> <td>80</td> <td>—</td> </tr> <tr> <td>CONTRAST RATIO</td> <td>CR</td> <td>0x=0° , 0y=0°</td> <td>510</td> <td>680</td> <td>—</td> <td>—</td> <td>NOTE (3)</td> </tr> <tr> <td>RESPONSE TIME</td> <td>T_r (rise)+ T_f (fall)</td> <td>0x=0° , 0y=0°</td> <td>—</td> <td>16</td> <td>32</td> <td>msec</td> <td>NOTE (4)</td> </tr> <tr> <td rowspan="8">COLOR OF CIE COORDINATE</td> <td rowspan="2">WHITE</td> <td>W_x</td> <td rowspan="8">0x=0° , 0y=0° NTSC : 45% VLED-VSS=12.0V</td> <td>0.25</td> <td>0.30</td> <td>0.35</td> <td rowspan="8">—</td> <td rowspan="8">NOTE (6)</td> </tr> <tr> <td>W_y</td> <td>0.30</td> <td>0.35</td> <td>0.40</td> </tr> <tr> <td>RED</td> <td>R_x</td> <td>0.54</td> <td>0.59</td> <td>0.64</td> </tr> <tr> <td>R_y</td> <td>0.31</td> <td>0.36</td> <td>0.41</td> </tr> <tr> <td>GREEN</td> <td>G_x</td> <td>0.25</td> <td>0.30</td> <td>0.35</td> </tr> <tr> <td>G_y</td> <td>0.52</td> <td>0.57</td> <td>0.62</td> </tr> <tr> <td>BLUE</td> <td>B_x</td> <td>0.10</td> <td>0.15</td> <td>0.20</td> </tr> <tr> <td>B_y</td> <td>0.07</td> <td>0.12</td> <td>0.17</td> </tr> <tr> <td>THE BRIGHTNESS OF MODULE</td> <td>B</td> <td>0x=0° , 0y=0° VLED-VSS=12.0V</td> <td>800</td> <td>1000</td> <td>—</td> <td>cd/m²</td> <td>NOTE (5)</td> </tr> </tbody> </table>	ITEM	SYMBOL	CONDITION	MIN.	TYP.	MAX.	UNIT	REMARK	VIEWING ANGLE	θ_{+}	CR ≥ 10	0x=0°	(60)	(70)	—	deg. NOTE (2) NOTE (3)	θ_{-}	(70)	(80)	—	θ_{+}	(70)	(80)	—	θ_{-}	(70)	(80)	—	CONTRAST RATIO	CR	0x=0° , 0y=0°	(400)	(500)	—	—	NOTE (3)	RESPONSE TIME	T _r (rise)+ T _f (fall)	0x=0° , 0y=0°	—	(16)	(32)	msec	NOTE (4)	COLOR OF CIE COORDINATE	WHITE	W _x	0x=0° , 0y=0° NTSC : 45% VLED-VSS=12.0V	(0.25)	(0.30)	(0.35)	—	NOTE (6)	W _y	(0.32)	(0.37)	(0.42)	RED	R _x	(0.555)	(0.605)	(0.655)	R _y	(0.277)	(0.327)	(0.377)	GREEN	G _x	(0.236)	(0.286)	(0.336)	G _y	(0.476)	(0.526)	(0.576)	BLUE	B _x	(0.10)	(0.15)	(0.20)	B _y	(0.095)	(0.145)	(0.195)	THE BRIGHTNESS OF MODULE	B	0x=0° , 0y=0° VLED-VSS=12.0V	(800)	(1000)	—	cd/m ²	NOTE (5)	ITEM	SYMBOL	CONDITION	MIN.	TYP.	MAX.	UNIT	REMARK	VIEWING ANGLE	θ_{+}	CR ≥ 10	0x=0°	60	70	—	deg. NOTE (2) NOTE (3)	θ_{-}	70	80	—	θ_{+}	70	80	—	θ_{-}	70	80	—	CONTRAST RATIO	CR	0x=0° , 0y=0°	510	680	—	—	NOTE (3)	RESPONSE TIME	T _r (rise)+ T _f (fall)	0x=0° , 0y=0°	—	16	32	msec	NOTE (4)	COLOR OF CIE COORDINATE	WHITE	W _x	0x=0° , 0y=0° NTSC : 45% VLED-VSS=12.0V	0.25	0.30	0.35	—	NOTE (6)	W _y	0.30	0.35	0.40	RED	R _x	0.54	0.59	0.64	R _y	0.31	0.36	0.41	GREEN	G _x	0.25	0.30	0.35	G _y	0.52	0.57	0.62	BLUE	B _x	0.10	0.15	0.20	B _y	0.07	0.12	0.17	THE BRIGHTNESS OF MODULE	B	0x=0° , 0y=0° VLED-VSS=12.0V	800	1000	—	cd/m ²
ITEM	SYMBOL	CONDITION	MIN.	TYP.	MAX.	UNIT	REMARK																																																																																																																																																																																		
VIEWING ANGLE	θ_{+}	CR ≥ 10	0x=0°	(60)	(70)	—	deg. NOTE (2) NOTE (3)																																																																																																																																																																																		
	θ_{-}			(70)	(80)	—																																																																																																																																																																																			
	θ_{+}			(70)	(80)	—																																																																																																																																																																																			
	θ_{-}			(70)	(80)	—																																																																																																																																																																																			
CONTRAST RATIO	CR	0x=0° , 0y=0°	(400)	(500)	—	—	NOTE (3)																																																																																																																																																																																		
RESPONSE TIME	T _r (rise)+ T _f (fall)	0x=0° , 0y=0°	—	(16)	(32)	msec	NOTE (4)																																																																																																																																																																																		
COLOR OF CIE COORDINATE	WHITE	W _x	0x=0° , 0y=0° NTSC : 45% VLED-VSS=12.0V	(0.25)	(0.30)	(0.35)	—	NOTE (6)																																																																																																																																																																																	
		W _y		(0.32)	(0.37)	(0.42)																																																																																																																																																																																			
	RED	R _x		(0.555)	(0.605)	(0.655)																																																																																																																																																																																			
	R _y	(0.277)		(0.327)	(0.377)																																																																																																																																																																																				
	GREEN	G _x		(0.236)	(0.286)	(0.336)																																																																																																																																																																																			
	G _y	(0.476)		(0.526)	(0.576)																																																																																																																																																																																				
	BLUE	B _x		(0.10)	(0.15)	(0.20)																																																																																																																																																																																			
	B _y	(0.095)		(0.145)	(0.195)																																																																																																																																																																																				
THE BRIGHTNESS OF MODULE	B	0x=0° , 0y=0° VLED-VSS=12.0V	(800)	(1000)	—	cd/m ²	NOTE (5)																																																																																																																																																																																		
ITEM	SYMBOL	CONDITION	MIN.	TYP.	MAX.	UNIT	REMARK																																																																																																																																																																																		
VIEWING ANGLE	θ_{+}	CR ≥ 10	0x=0°	60	70	—	deg. NOTE (2) NOTE (3)																																																																																																																																																																																		
	θ_{-}			70	80	—																																																																																																																																																																																			
	θ_{+}			70	80	—																																																																																																																																																																																			
	θ_{-}			70	80	—																																																																																																																																																																																			
CONTRAST RATIO	CR	0x=0° , 0y=0°	510	680	—	—	NOTE (3)																																																																																																																																																																																		
RESPONSE TIME	T _r (rise)+ T _f (fall)	0x=0° , 0y=0°	—	16	32	msec	NOTE (4)																																																																																																																																																																																		
COLOR OF CIE COORDINATE	WHITE	W _x	0x=0° , 0y=0° NTSC : 45% VLED-VSS=12.0V	0.25	0.30	0.35	—	NOTE (6)																																																																																																																																																																																	
		W _y		0.30	0.35	0.40																																																																																																																																																																																			
	RED	R _x		0.54	0.59	0.64																																																																																																																																																																																			
	R _y	0.31		0.36	0.41																																																																																																																																																																																				
	GREEN	G _x		0.25	0.30	0.35																																																																																																																																																																																			
	G _y	0.52		0.57	0.62																																																																																																																																																																																				
	BLUE	B _x		0.10	0.15	0.20																																																																																																																																																																																			
	B _y	0.07		0.12	0.17																																																																																																																																																																																				
THE BRIGHTNESS OF MODULE	B	0x=0° , 0y=0° VLED-VSS=12.0V	800	1000	—	cd/m ²	NOTE (5)																																																																																																																																																																																		
	13	11. POWER SUPPLY DELETE 11.2 POWER 、 SIGNAL SEQUENCE																																																																																																																																																																																							

TABLE OF CONTENTS

NO.	ITEM	PAGE
1.	GENERAL SPECIFICATIONS -----	1
2.	MECHANICAL SPECIFICATIONS -----	1
3.	ABSOLUTE MAXIMUM RATINGS -----	2
4.	ELECTRICAL CHARACTERISTICS -----	3, 4
5.	TIMING CHARACTERISTICS -----	5, 6
6.	OPTICAL CHARACTERISTICS -----	7, 8
7.	OUTLINE DIMENSIONS -----	9
8.	BLOCK DIAGRAM -----	10
9.	DETAIL DRAWING OF DOT MATRIX -----	11
10.	INTERFACE SIGNALS -----	12
11.	POWER SUPPLY -----	13
12.	INSPECTION CRITERION -----	14 ~ 23

CONFIDENTIAL
Authorized for
Emerging Display Technologies Corporation Only.
Do not distribute without authorization.

1. GENERAL SPECIFICATIONS

1.1 DATA SHEETS FOR CONTROLLER/DRIVER

PLEASE REFER TO :

SITRONIX ST5651CB

SITRONIX ST5021

1.2 MATERIAL SAFETY DESCRIPTION

ASSEMBLIES SHALL COMPLY WITH EDT GREEN PRODUCT (GP) REQUIREMENTS, INCLUDING PROHIBITED MATERIALS/COMPONENTS CONTAINING LEAD, MERCURY, CADMIUM, HEXAVALENT CHROMIUM, POLYBROMINATED BIPHENYLS (PBB), POLYBROMINATED DIPHENYL ETHERS (PBDE), POLYCHLORINATED BIPHENYLS (PCB) CATEGORY, POLYCHLORINATED NAPHTHALENE (PCN) CATEGORY, POLYCHLORINATED TERPHENYLS (PCT) CATEGORY, CHLORINATED PARAFFINS (CP) CATEGORY, TRIBUTHYL TIN CATEGORY / TRIPHENYL TIN CATEGORY, ASBESTOS, SPECIFIC AZO COMPOUNDS, FORMALDEHYDE, POLYVINYL CHLORIDE (PVC) AND PVC BLENDS, OTHER BROMINATED ORGANIC COMPOUNDS AND OTHER CHLORINATED ORGANIC COMPOUNDS.

2. MECHANICAL SPECIFICATIONS

(1) DISPLAY SIZE	-----	10.1 inch
(2) NUMBER OF DOTS	-----	1024W * (RGB) * 600H DOTS
(3) MODULE SIZE	-----	235.5W * 143H * 9.3D(MAX.) mm
(4) VIEWING AREA	-----	225.4W * 128H mm
(5) ACTIVE AREA	-----	222.72W * 125.28H mm
(6) DOT SIZE	-----	0.0725W * 0.2088H mm
(7) PIXEL SIZE	-----	0.2175W * 0.2088H mm
(8) LCD TYPE	-----	TFT , TRANSMISSIVE , ANTI-GLARE
(9) COLOR	-----	16.7 M
(10) VIEWING DIRECTION	-----	6 O'CLOCK (GRAY LEVEL INVERSION)
(11) BACK LIGHT	-----	LED , COLOR : WHITE
(12) INTERFACE MODE	-----	LVDS

3. ABSOLUTE MAXIMUM RATINGS

3.1 ELECTRICAL ABSOLUTE MAXIMUM RATINGS

ITEM	SYMBOL	MIN.	MAX.	UNIT	REMARK
POWER SUPPLY VOLTAGE	VDD-VSS	-0.5	5.0	V	
LED BACKLIGHT POWER DISSIPATION	PD	—	18.36	W	
LED BACKLIGHT FORWARD CURRENT	IF	—	900	mA	
LED BACKLIGHT REVERSE VOLTAGE	VR	—	7.2	V	

NOTE (1) : LCM SHOULD BE GROUND DURING HANDLING LCM.

3.2 ENVIRONMENTAL ABSOLUTE MAXIMUM RATINGS

ITEM	OPERATING		STORAGE		REMARK
	MIN.	MAX.	MIN.	MAX.	
AMBIENT TEMPERATURE	-30°C	80°C	-30°C	80°C	NOTE (1), (2)
HUMIDITY	NOTE (3)		NOTE (3)		WITHOUT CONDENSATION
VIBRATION	—	2.45 m/s ² (0.25 G)	—	11.76m/s ² (1.2 G)	10~55Hz X,Y,Z,EACH 2HRS
SHOCK	—	29.4 m/s ² (3 G)	—	490.0 m/s ² (50 G)	6 ms XYZ DIRECTIONS 3 TIMES EACH
CORROSIVE GAS	NOT ACCEPTABLE		NOT ACCEPTABLE		

NOTE (1) : Ta AT -30°C : WILL BE 48HRS MAX.

80°C : WILL BE 48HRS MAX.

NOTE (2) : BACKGROUND COLOR CHANGES SLIGHTLY DEPENDING ON AMBIENT TEMPERATURE THIS PHENOMENON IS REVERSIBLE.

NOTE (3) : Ta ≤ 60°C : 90%RH MAX. (96HRS MAX).

Ta > 60°C : ABSOLUTE HUMIDITY MUST BE LOWER THAN THE HUMIDITY OF 90%RH AT 60°C (96HRS MAX).

4. ELECTRICAL CHARACTERISTICS

ITEM	SYMBOL	CONDITION	MIN.	TYP.	MAX.	UNIT	REMARK
LOGIC/LCD DRIVE VOLTAGE	VDD-VSS	—	3.0	3.3	3.6	V	
VDD CURRENT	IDD	—	—	150	190	mA	
POWER SUPPLY VOLTAGE FOR LED DRIVER	VLED-VSS	—	11.7	12.0	12.3	V	
POWER SUPPLY CURRENT FOR LED DRIVER	IVLED	VLED-VSS=12.0V	—	500	625	mA	
DIFFERENTIAL INPUT HIGH THRESHOLD VOLTAGE	RxVTH	RxVCM=1.2V	—	—	0.1	V	
DIFFERENTIAL INPUT LOW THRESHOLD VOLTAGE	RxVTL		-0.1	—	—	V	
INPUT VOLTAGE RANGE (SINGLED-END)	RxVIN	—	0	—	2.4	V	
DIFFERENTIAL INPUT COMMON MODE VOLTAGE	RxVCM	—	VID /2	—	2.4- VID /2	V	
DIFFERENTIAL INPUT VOLTAGE	VID	—	0.2	—	0.6	V	
DIFFERENTIAL INPUT LEAKAGE CURRENT	RVxIiz	—	-10	—	+10	μA	
LVDS DIGITAL OPERATING CURRENT	Iddlvs	Fclk=65MHz, VDD-VSS=3.3V	—	40	50	mA	
LVDS DIGITAL STANDBY CURRENT	Istlvs	CLOCK & ALL FUNCTIONS ARE STOPPED	—	10	50	μA	
LED LIFE TIME		ILED=120mA (PER. LED)	50K	—	—	HRS	NOTE (5) NOTE (6)

NOTE (1) : A. INPUT SIGNALS SHALL BE LOW OR HI-Z STATE WHEN VDD IS OFF.

B. ALL ELECTRICAL CHARACTERISTICS FOR LVDS SIGNAL ARE DEFINED AND SHALL BE MEASURED AT THE INTERFACE CONNECTOR OF LCD.

NOTE (2) : LVDS INPUT CHARACTERISTICS ARE AS FOLLOWS

Single-end Signals

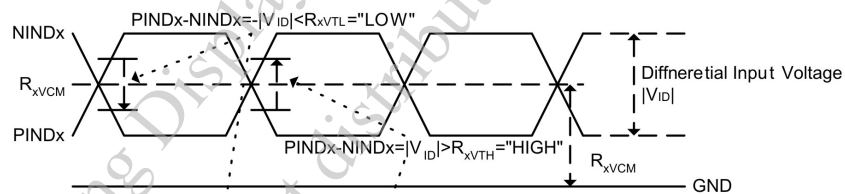

Differential Signal

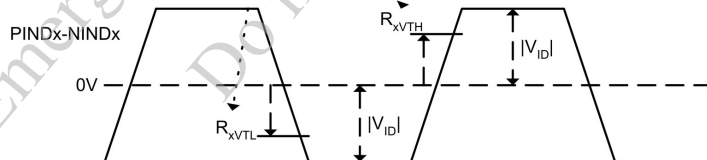

NOTE (3) : AMBIENT TEMP. VS. ALLOWABLE FORWARD CURRENT. (PER. LED)

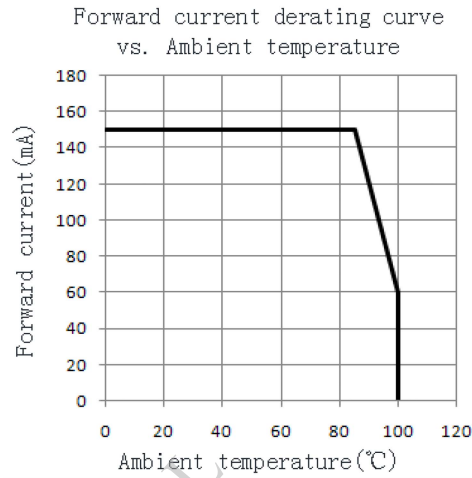

NOTE (4) : INTERNAL CIRCUIT DIAGRAM OF BACKLIGHT

$$VF = VBL1+(A1) - VBL1-(K1) = VBL2+(A2) - VBL2-(K2)$$

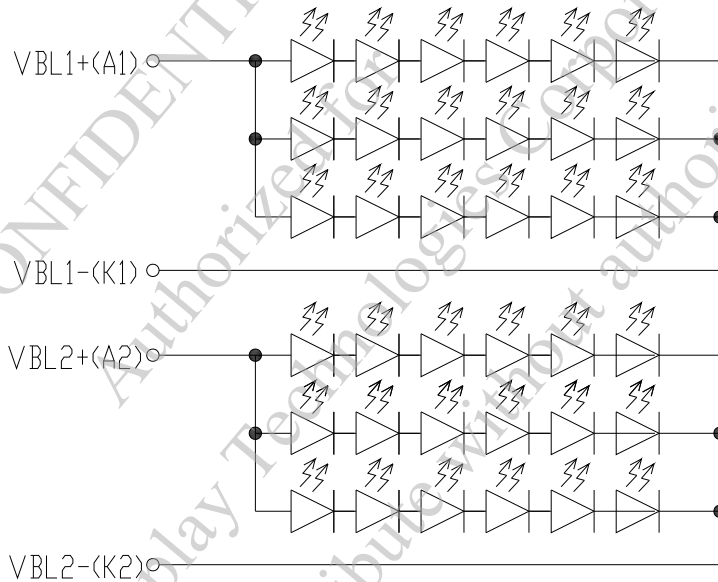

NOTE (5) : CONDITIONS; TA=25 °C, CONTINUOUS LIGHTING

NOTE (6) : DEFINITIONS OF LIFE TIME

LCM LUMINANCE BECOMES HALF OF THE INITIAL VALUE.

5. TIMING CHARACTERISTICS

5.1 DATA INPUT FORMAT

5.1.1 8 BIT LVDS INPUT(HSD='L')

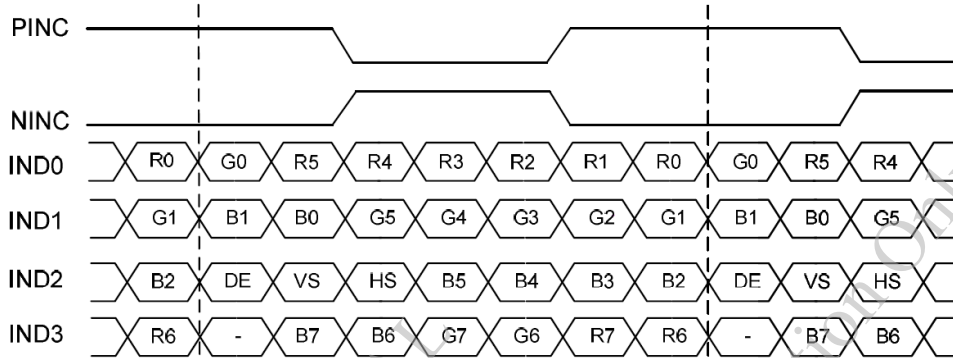

5.2 TIMING TABLE

5.2.1 MODE = "H" : DE MODE

ITEM	SYMBOL	MIN.	TYP.	MAX.	UNIT
CLKIN FREQUENCY@ FRAME RATE = 60Hz	fclk	40.8	51.2	67.2	MHz
HORIZONTAL DISPLAY AREA	thd	1024			CLKIN
1 HORIZONTAL LINE	th	1114	1344	1400	
HSD BLANKING	thb+thfp	90	320	376	
VERTICAL DISPLAY AREA	tvd	600			H
1 VERTICAL LINE	tv	610	635	800	
VSD BLANKING	tvb+tvfp	10	45	220	

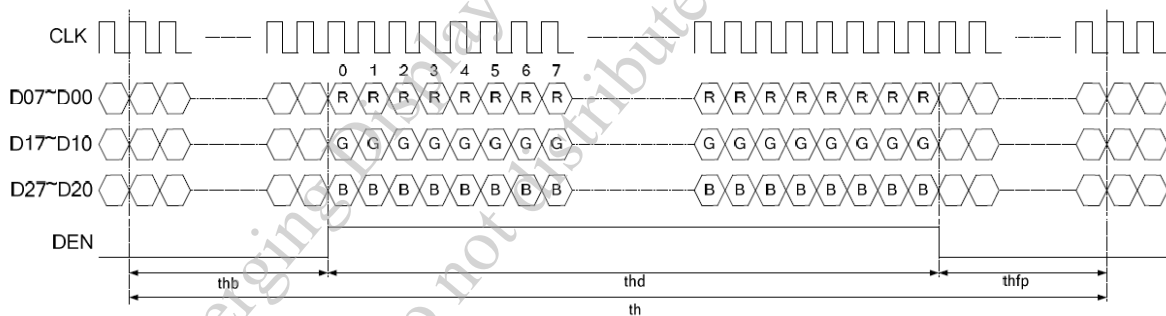

5.3 AC ELECTRICAL CHARACTERISTICS

LVDS MODE

ITEM	SYMBOL	MIN.	TYP.	MAX.	UNIT	CONDITION
CLOCK FREQUENCY	R _x FCLK	20	—	71	MHz	
INPUT DATA SKEW MARGIN	T _{RSKM}	500	—	—	pS	V _{ID} = 400mV R _x VCM = 1.2V R _x FCLK = 71 MHz
CLOCK HIGH TIME	T _{LVCH}	—	4/(7* R _x FCLK)	—	ns	
CLOCK LOW TIME	T _{LVCL}	—	3/(7* R _x FCLK)	—	ns	
PLL WAKE-UP TIME	T _{enPLL}		—	150	us	

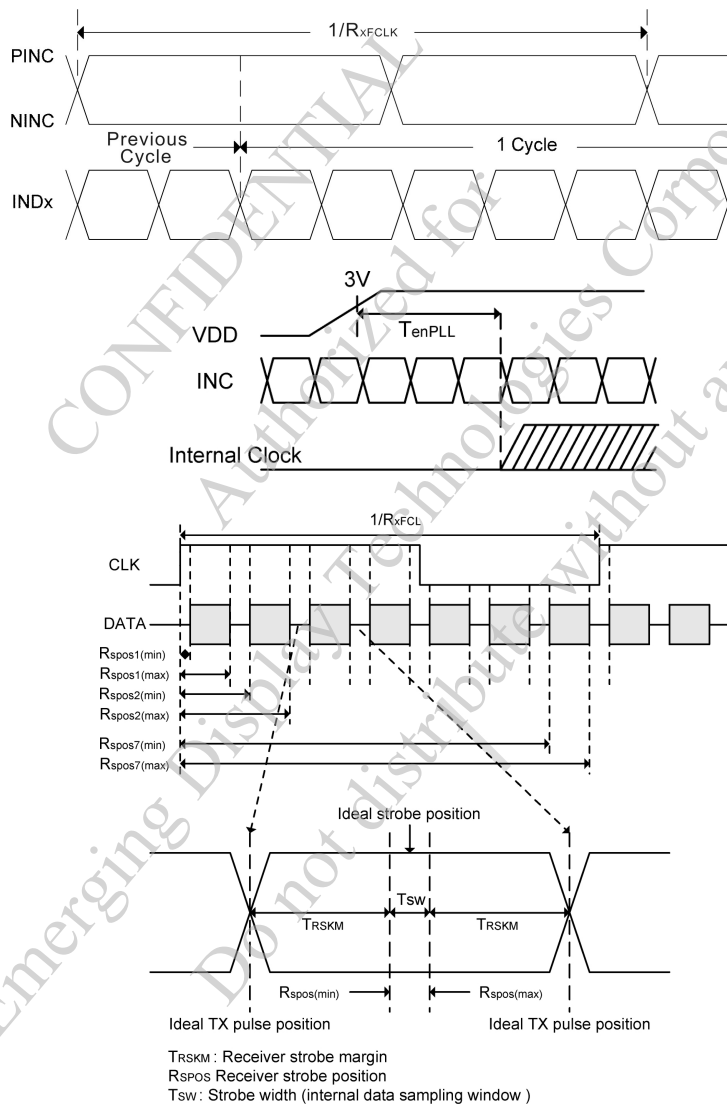

ITEM	SYMBOL	CONDITION	MIN.	TYP.	MAX.	UNIT
MODULATION FREQUENCY	SSCMF	—	23	—	93	KHz
MODULATION RATE	SSCMR	LVDS CLOCK=71MHz CENTER SPREAD	—	—	±3	%

6. OPTICAL CHARACTERISTICS (NOTE 1)

6.1 OPTICAL CHARACTERISTICS

Ta = 25 ± 2 °C

ITEM	SYMBOL	CONDITION	MIN.	TYP.	MAX.	UNIT	REMARK	
VIEWING ANGLE	θ_{y+}	CR ≥ 10	$\theta_x=0^\circ$	60	70	—	deg.	NOTE (2) NOTE (3)
	θ_{y-}			70	80	—		
	θ_{x+}		$\theta_y=0^\circ$	70	80	—		
	θ_{x-}			70	80	—		
CONTRAST RATIO	CR	$\theta_x=0^\circ, \theta_y=0^\circ$	510	680	—	—	NOTE (3)	
RESPONSE TIME	T _R (rise) + T _F (fall)	$\theta_x=0^\circ, \theta_y=0^\circ$	—	16	32	msec	NOTE (4)	
COLOR OF CIE COORDINATE	WHITE	W _x	$\theta_x=0^\circ, \theta_y=0^\circ$ NTSC : 45% VLED-VSS=12.0V	0.25	0.30	0.35	—	NOTE (6)
		W _y		0.30	0.35	0.40		
	RED	R _x		0.54	0.59	0.64		
		R _y		0.31	0.36	0.41		
	GREEN	G _x		0.25	0.30	0.35		
		G _y		0.52	0.57	0.62		
	BLUE	B _x		0.10	0.15	0.20		
		B _y		0.07	0.12	0.17		
THE BRIGHTNESS OF MODULE	B	$\theta_x=0^\circ, \theta_y=0^\circ$	800	1000	—	cd/m ²	NOTE (5)	
THE UNIFORMITY OF MODULE	—	VLED-VSS=12.0V	70	—	—	%	NOTE (5)	

NOTE (1) : TEST EQUIPMENT SETUP :

AFTER STABILIZING AND LEAVING THE PANEL ALONE AT A GIVEN TEMPERATURE FOR 30 MINUTES, THE MEASUREMENT SHOULD BE EXECUTED. MEASUREMENT SHOULD BE EXECUTED IN A STABLE, WINDLESS, AND DARK ROOM. OPTICAL SPECIFICATIONS ARE MEASURED BY TOPCON BM-7 (FAST) WITH A VIEWING ANGLE OF 1° AT A DISTANCE OF 50cm AND NORMAL DIRECTION.

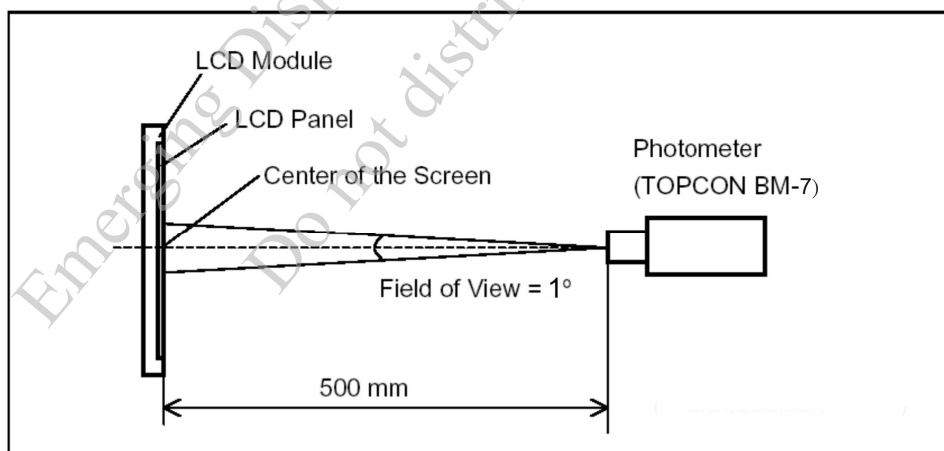

NOTE (2) : DEFINITION OF VIEWING ANGLE :

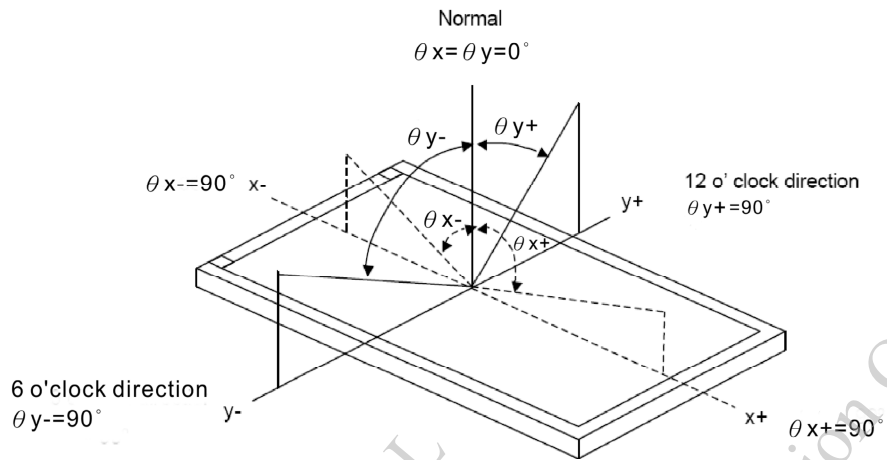

NOTE (3) : DEFINITION OF CONTRAST RATIO :

$$\text{CONTRAST RATIO (CR)} = \frac{\text{BRIGHTNESS MEASURED WHEN LCD IS AT "WHITE STATE"}}{\text{BRIGHTNESS MEASURED WHEN LCD IS AT "BLACK STATE"}}$$

NOTE (4) : DEFINITION OF RESPONSE TIME : T_R AND T_F

THE FIGURE BELOW IS THE OUTPUT SIGNAL OF THE PHOTO DETECTOR.

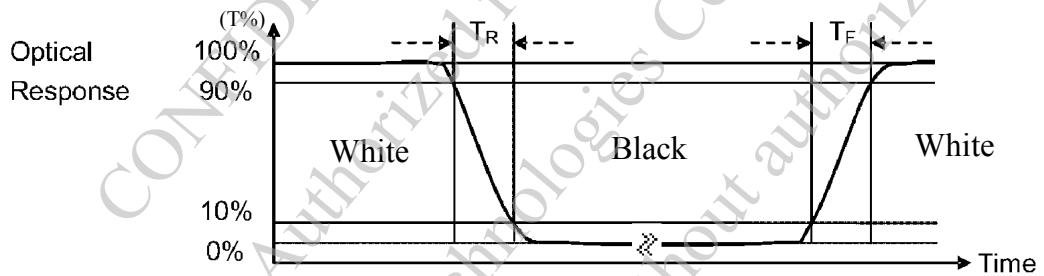

NOTE (5) : BRIGHTNESS MEASURED WHEN LCD IS AT "WHITE STATE"

NOTE (6) : THE 100% TRANSMISSION IS DEFINED AS THE TRANSMISSION OF LCD PANEL WHEN ALL THE INPUT TERMINALS OF MODULE ARE ELECTRICALLY OPENED.

6.2 THE TEST METHOD OF BRIGHTNESS AND UNIFORMITY

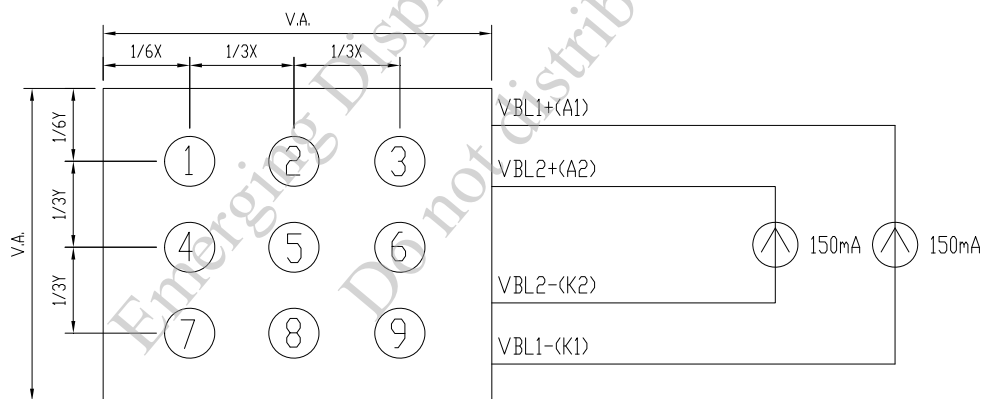

6.3 THE CALCULATING METHOD OF UNIFORMITY

$$\text{UNIFORMITY} : \left[1 - \frac{\text{MAXIMUM BRIGHTNESS} - \text{MINIMUM BRIGHTNESS}}{\text{AVERAGE BRIGHTNESS}} \right] \times 100\%$$

7. OUTLINE DIMENSIONS

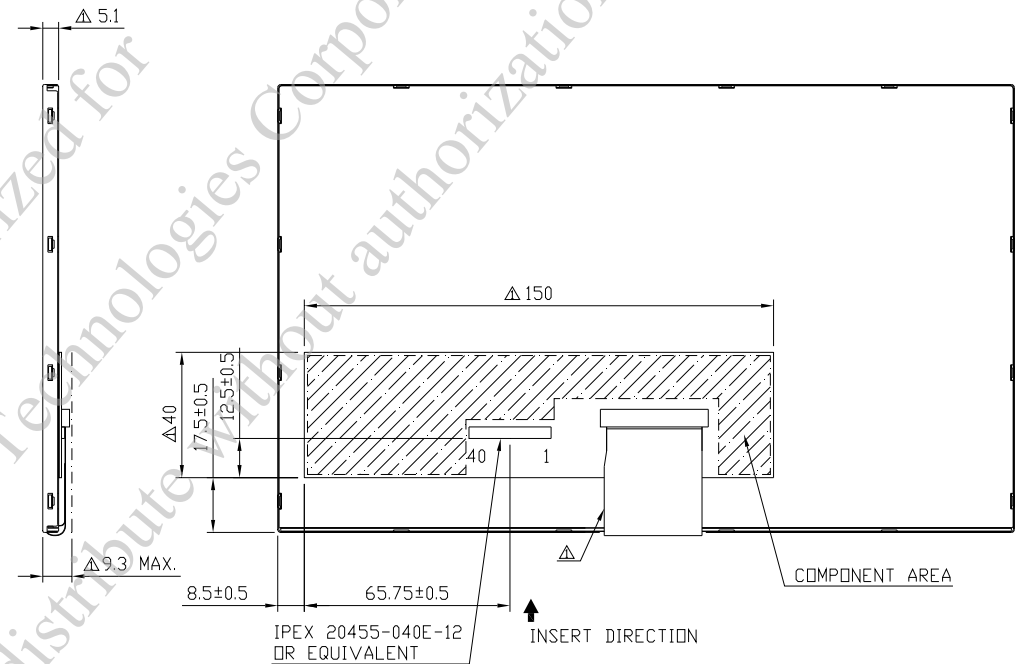
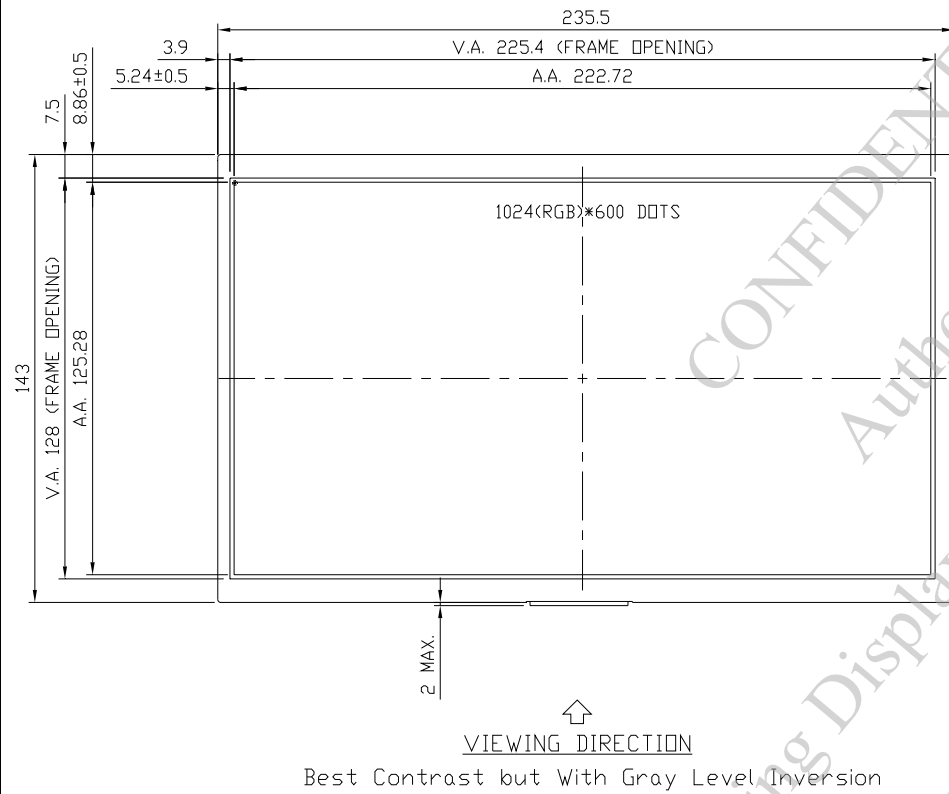

UNIT : mm

SCALE : NTS

NOT SPECIFIED TOLERANCE IS ± 0.3

NOTE : MARK △ MODIFY (NUMBER NOTE MODIFY VERSION)

8. BLOCK DIAGRAM

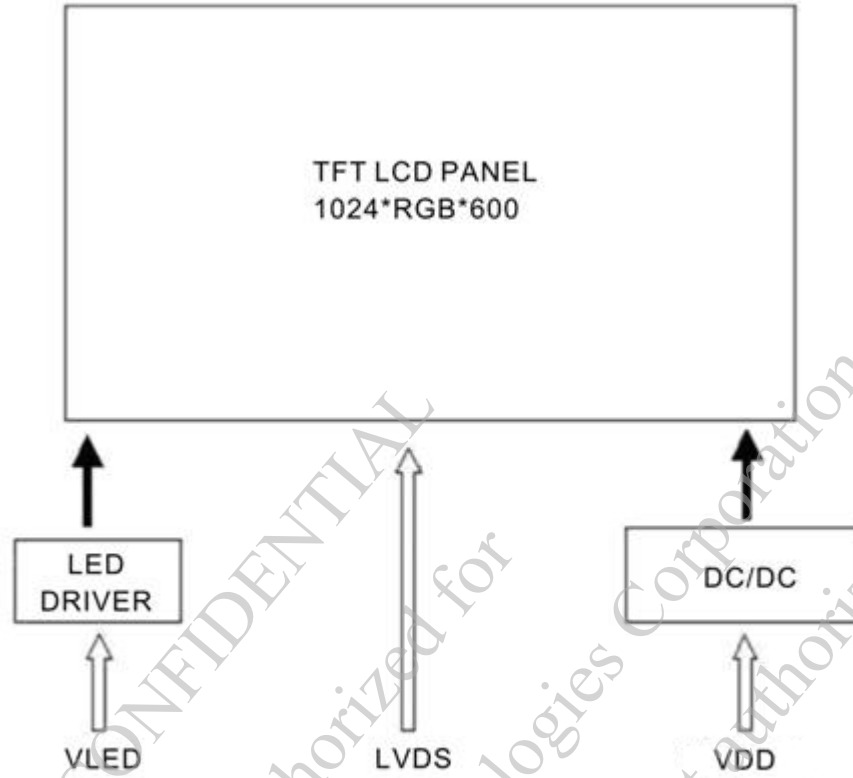

9. DETAIL DRAWING OF DOT MATRIX

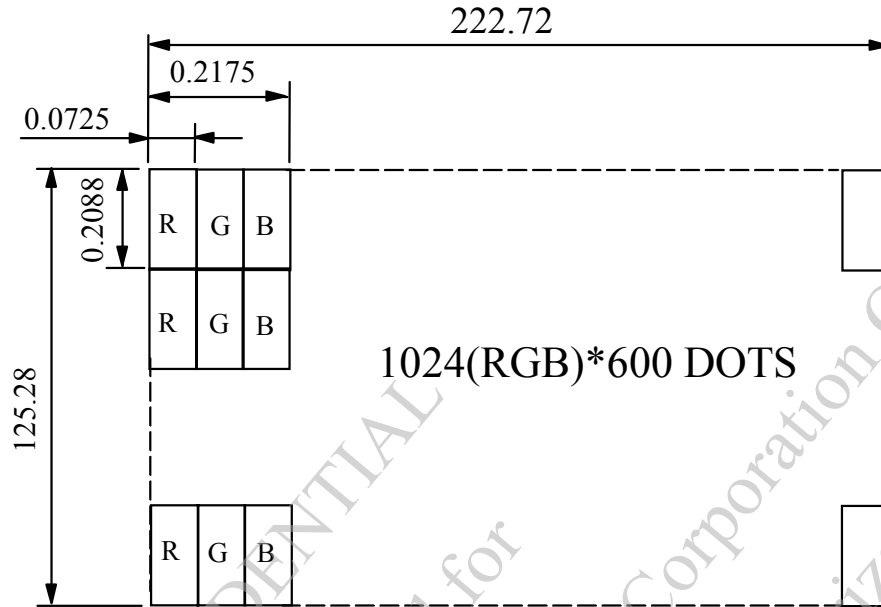

UNIT : mm

SCALE : NTS

NOT SPECIFIED TOLERANCE IS ± 0.1

DOTS MATRIX TOLERANCE IS ± 0.01

CONFIDENTIAL
Authorized for
Emerging Display Technologies Corporation Only.
Do not distribute without authorization.

10. INTERFACE SIGNALS

PIN NO.	SYMBOL	FUNCTION
1	NC	NON CONNECTION
2	VDD	POWER SUPPLY VOLTAGE
3	VDD	POWER SUPPLY VOLTAGE
4	NC	NON CONNECTION
5	NC	NON CONNECTION
6	NC	NON CONNECTION
7	NC	NON CONNECTION
8	IND0-	LVDS SIGNAL (-) — CHANNEL 0 (R0~R5,G0)
9	IND0+	LVDS SIGNAL (+) — CHANNEL 0 (R0~R5,G0)
10	VSS	GROUND
11	IND1-	LVDS SIGNAL (-) — CHANNEL 1 (G1~G5,B0~B1)
12	IND1+	LVDS SIGNAL (+) — CHANNEL 1 (G1~G5,B0~B1)
13	VSS	GROUND
14	IND2-	LVDS SIGNAL (-) — CHANNEL 2 (B2~B5,VS,HS,DE)
15	IND2+	LVDS SIGNAL (+) — CHANNEL 2 (B2~B5,VS,HS,DE)
16	VSS	GROUND
17	NINC	LVDS CLOCK SIGNAL (-)
18	PINC	LVDS CLOCK SIGNAL (+)
19	VSS	GROUND
20	IND3-	LVDS SIGNAL (-) — CHANNEL 3 (R6,R7,G6,G7,B6,B7)
21	IND3+	LVDS SIGNAL (+) — CHANNEL 3 (R6,R7,G6,G7,B6,B7)
22	VSS	GROUND
23	NC	NON CONNECTION
24	NC	NON CONNECTION
25	VSS	GROUND
26	NC	NON CONNECTION
27	NC	NON CONNECTION
28	VSS	GROUND
29	NC	NON CONNECTION
30	NC	NON CONNECTION
31	VSS	GROUND
32	VSS	GROUND
33	VSS	GROUND
34	NC	NON CONNECTION
35	PWM	ADJUST FOR LED BRIGHTNESS
36	LED-ENABLE	INTERNAL PULL UP TO +3.3V
37	NC	NON CONNECTION
38	VLED	POWER SUPPLY VOLTAGE FOR LED BACKLIGHT
39	VLED	POWER SUPPLY VOLTAGE FOR LED BACKLIGHT
40	VLED	POWER SUPPLY VOLTAGE FOR LED BACKLIGHT

11. POWER SUPPLY

11.1 POWER SUPPLY FOR LCM

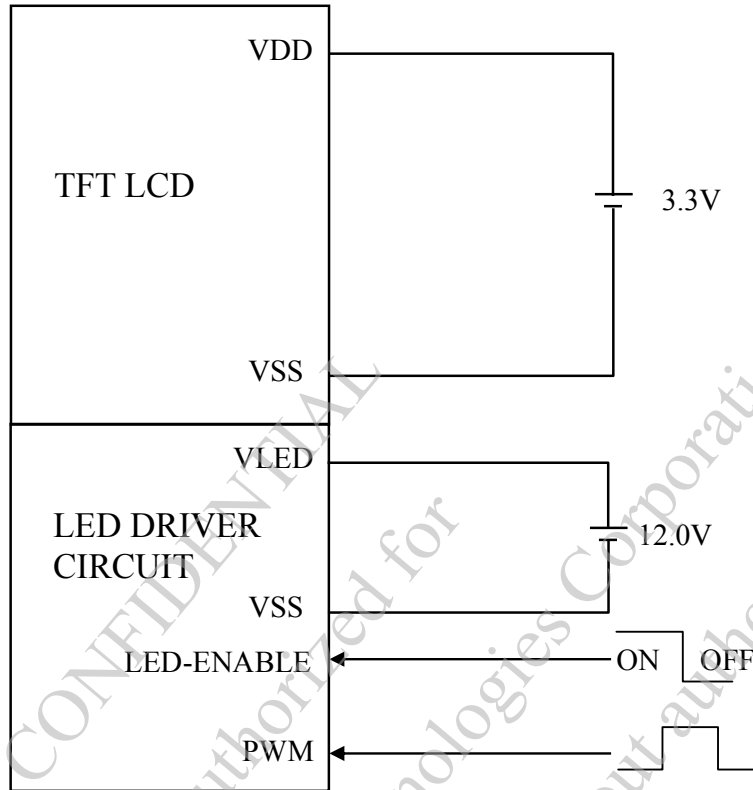

NOTE (1) : PWM ADJUST BRIGHTNESS TO CONTROL PIN, PULSE DUTY THE BIGGER THE BRIGHTER.

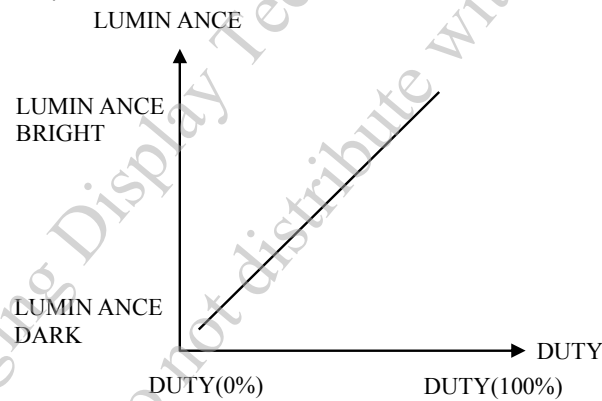

NOTE (2) : PWM SIGNAL=0~3.3V , OPERATION FREQUENCY : 20KHz±5KHz

$$F=20\text{KHz}\pm 5 \text{ KHz}$$

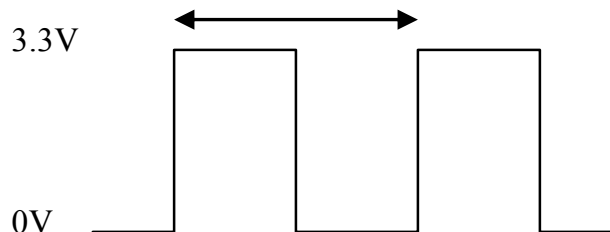

12. INSPECTION CRITERION

12.1 APPLICATION

THIS INSPECTION STANDARD IS TO BE APPLIED TO THE LCD MODULE DELIVERED FROM EMERGING DISPLAY TECHNOLOGIES CORP.(E.D.T) TO CUSTOMERS

12.2 INSPECTION CONDITIONS

12.2.1 (1)OBSERVATION DISTANCE : 35±5cm

(2)VIEW ANGLE :

NON-OPERATION CONDITION : ±5°

(PERPENDICULAR TO LCD PANEL SURFACE)

OPERATION CONDITION : ±45°

(PERPENDICULAR TO LCD PANEL SURFACE)

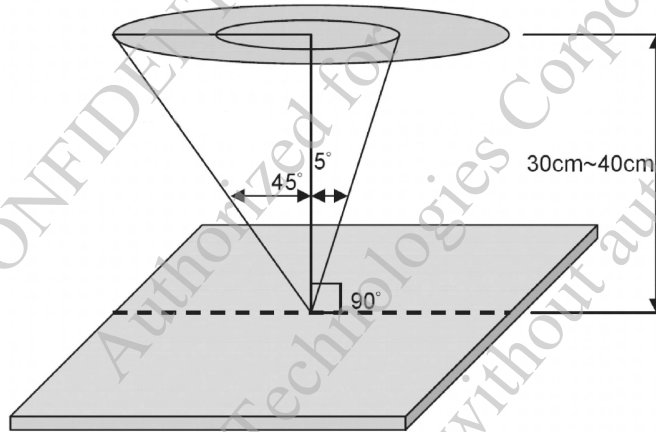

12.2.2 ENVIRONMENT CONDITIONS :

AMBIENT TEMPERATURE		25±5°C
AMBIENT HUMIDITY		65±20%RH
AMBIENT ILLUMINATION	COSMETIC INSPECTION	MORE THAN 600Lux
	FUNCTIONAL INSPECTION	300~500 Lux

12.2.3 INSPECTION LOT

QUANTITY PER DELIVERY LOT FOR EACH MODEL

12.2.4 INSPECTION METHOD

A SAMPLING INSPECTION SHALL BE MADE ACCORDING TO THE FOLLOWING PROVISIONS TO JUDGE THE ACCEPTABILITY

(a)APPLICABLE STANDARD :

MIL-STD-105E

NORMAL INSPECTION, SINGLE SAMPLING

Level II

(b)AQL : MAJOR DEFECT : AQL 0.65

MINOR DEFECT : AQL 1.0

12.3 INSPECTION STANDARDS

12.3.1 VISUAL DEFECTS CLASSIFICATION

TYPE OF DEFECT	INSPECTION ITEM	DEFECT FEATURE	AQL
MAJOR DEFECT	1.DISPLAY ON	<ul style="list-style-type: none"> • DEFECT TO MISS SPECIFIED DISPLAY FUNCTION, FOR ALL AND SPECIFIED DOTS EX: DISCONNECTION, SHORT CIRCUIT ETC 	0.65
	2.BACKLIGHT	<ul style="list-style-type: none"> • NO LIGHT • FLICKERING AND OTHER ABNORMAL ILLUMINATION 	
	3.DIMENSIONS	<ul style="list-style-type: none"> • SUBJECT TO INDIVIDUAL ACCEPTANCE SPECIFICATIONS 	
MINOR DEFECT	1.DISPLAY ZONE	<ul style="list-style-type: none"> • BLACK/WHITE SPOT • BUBBLES ON POLARIZER • NEWTON RING • BLACK/WHITE LINE • SCRATCH • CONTAMINATION • UNEVEN COLOR SPREAD 	1.0
	2.BEZEL ZONE	<ul style="list-style-type: none"> • STAINS • SCRATCHES • FOREIGN MATTER 	
	3.SOLDERING	<ul style="list-style-type: none"> • INSUFFICIENT SOLDER • SOLDERED IN INCORRECT POSITION • CONVEX SOLDERING SPOT • SOLDER BALLS • SOLDER SCRAPS 	
	4.DISPLAY ON (ALL ON)	<ul style="list-style-type: none"> • LIGHT LINE 	

12.3.2 MODULE DEFECTS CLASSIFICATION

NO.	ITEM	CRITERIA												
1	DISPLAY ON INSPECTION	(1)INCORRECT PATTERN (2)MISSING SEGMENT (3)DIM SEGMENT (4)OPERATING VOLTAGE BEYOND SPEC												
2	OVERALL DIMENSIONS	(1)OVERALL DIMENSION BEYOND SPEC												
3	DOT DEFECT	(1)INSPECTION PATTERN: FULL WHITE, FULL BLACK, RED, GREEN AND BLUE SCREENS. (2) <table border="1" style="margin-left: 20px;"> <thead> <tr> <th>ITEMS</th> <th>ACCEPTABLE COUNT</th> </tr> </thead> <tbody> <tr> <td>BRIGHT DOT</td> <td>$N \leq 3$</td> </tr> <tr> <td>DARK DOT</td> <td>$N \leq 4$</td> </tr> <tr> <td>TOTAL BRIGHT AND DARK DOTS</td> <td>$N \leq 5$</td> </tr> </tbody> </table> <p>NOTE :</p> <p>1. THE DEFINITION OF DOT : THE SIZE OF A DEFECTIVE DOT OVER 1/2 OF WHOLE DOT IS REGARDED AS ONE DEFECTIVE DOT.</p> <p>2. BRIGHT DOT : DOTS APPEAR BRIGHT AND UNCHANGED IN SIZE IN WHICH LCD PANEL IS DISPLAYING UNDER BLACK PATTERN.</p> <p>3. DARK DOT : DOTS APPEAR DARK AND UNCHANGED IN SIZE IN WHICH LCD PANEL IS DISPLAYING UNDER PURE RED, GREEN, BLUE PICTURE.</p>	ITEMS	ACCEPTABLE COUNT	BRIGHT DOT	$N \leq 3$	DARK DOT	$N \leq 4$	TOTAL BRIGHT AND DARK DOTS	$N \leq 5$				
ITEMS	ACCEPTABLE COUNT													
BRIGHT DOT	$N \leq 3$													
DARK DOT	$N \leq 4$													
TOTAL BRIGHT AND DARK DOTS	$N \leq 5$													
4	FOREIGN BLACK/WHITE/ BRIGHT LINE/ SCRATCH OF VIEWING AREA	<table border="1" style="margin-left: 20px;"> <thead> <tr> <th>LENGTH : L</th> <th>WIDTH : W</th> <th>PERMISSIBLE NO.</th> </tr> </thead> <tbody> <tr> <td>$L \leq 1.0$</td> <td>$W \leq 0.05$</td> <td>IGNORE</td> </tr> <tr> <td>$1.0 < L \leq 10$</td> <td>$0.05 < W \leq 0.1$</td> <td>4</td> </tr> <tr> <td>$10 < L$</td> <td>$0.1 < W$</td> <td>NONE</td> </tr> </tbody> </table> <p>WIDTH : W mm, LENGTH : L mm</p>	LENGTH : L	WIDTH : W	PERMISSIBLE NO.	$L \leq 1.0$	$W \leq 0.05$	IGNORE	$1.0 < L \leq 10$	$0.05 < W \leq 0.1$	4	$10 < L$	$0.1 < W$	NONE
LENGTH : L	WIDTH : W	PERMISSIBLE NO.												
$L \leq 1.0$	$W \leq 0.05$	IGNORE												
$1.0 < L \leq 10$	$0.05 < W \leq 0.1$	4												
$10 < L$	$0.1 < W$	NONE												
5	FOREIGN MATTER \ BLACK SPOTS \ WHITE SPOTS \ DENT (INCLUDING LIGHT LEAKAGE DUE TO POLARIZING PLATES PINHOLES, ETC.)	<table border="1" style="margin-left: 20px;"> <thead> <tr> <th>AVERAGE DIAMETER (mm): D</th> <th>NUMBER OF PIECES PERMITTED</th> </tr> </thead> <tbody> <tr> <td>$D \leq 0.15$</td> <td>IGNORE</td> </tr> <tr> <td>$0.15 < D \leq 0.5$</td> <td>4</td> </tr> <tr> <td>$0.5 < D$</td> <td>NONE</td> </tr> </tbody> </table> <p>NOTE : DIAMETER $D=(a+b)/2$</p> 	AVERAGE DIAMETER (mm): D	NUMBER OF PIECES PERMITTED	$D \leq 0.15$	IGNORE	$0.15 < D \leq 0.5$	4	$0.5 < D$	NONE				
AVERAGE DIAMETER (mm): D	NUMBER OF PIECES PERMITTED													
$D \leq 0.15$	IGNORE													
$0.15 < D \leq 0.5$	4													
$0.5 < D$	NONE													

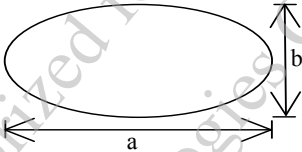
NO.	ITEM	CRITERIA		
			AVERAGE DIAMETER (mm) : D	NUMBER OF PIECES PERMITTED
6	BUBBLES OF POLARIZER /DIRT/CF FAIL /SURFACE STAINS	BUBBLE ON THE POLARIZER	$D \leq 0.15$	LGNORE
			$0.15 < D \leq 0.5$	$N \leq 4$
			$0.5 < D$	NONE
		SURFACE STAINS	$D < 0.1$	IGNORE
			$0.1 < D \leq 0.3$	$N \leq 3$
		CF FAIL / SPOT	$D < 0.1$	IGNORE
$0.1 < D \leq 0.3$	$N \leq 3$			
		<p>NOTE : (1)POLARIZER BUBBLE IS DEFINED AS THE BUBBLE APPEARS ON ACTIVE DISPLAY AREA. THE DEFECT OF POLARIZER BUBBLE SHALL BE IGNORED IF THE POLARIZER BUBBLE APPEARS ON THE OUTSIDE OF ACTIVE DISPLAY AREA.</p> <p>(2)THE EXTRANEIOUS SUBSTANCE IS DEFINED AS IT CAN BE OBSERVED WHEN THE MODULE IS POWER ON.</p> <p>(3)THE DEFINITION OF AVERAGE DIAMETER, D IS DEFINED AS FOLLOWING.</p> <p>AVERAGE DIAMETER (D)=(a+b)/2</p> 		
7	LINE DEFECT ON DISPLAY	OBVIOUS VERTICAL OR HORIZONTAL LINE DEFECT IS NOT ALLOWED		
8	MURA ON DISPLAY	IT'S OK IF MURA IS SLIGHT VISIBLE THROUGH 5% ND FILTER		
9	UNEVEN COLOR SPREAD, COLORATION	(1)TO BE DETERMINED BASED UPON THE STANDARD SAMPLE.		
10	BEZEL APPEARANCE	(1)BEZEL MAY NOT HAVE RUST, BE DEFORMED OR HAVE FINGER PRINTS STAINS OF OTHER CONTAMINATION. (2)BEZEL MUST COMPLY WITH JOB SPECIFICATIONS.		
11	PCB	<p>(1)THERE MAY NOT BE MORE THAN 2mm OF SEALANT OUTSIDE THE SEAL AREA ON THE PCB, AND THERE SHOULD BE NO MORE THAN THREE PLACES.</p> <p>(2)NO OXIDATION OR CONTAMINATION PCB TERMINALS.</p> <p>(3)PARTS ON PCB MUST BE THE SAME AS ON THE PRODUCTION CHARACTERISTIC CHART. THERE SHOULD BE NO WRONG PARTS, MISSING PARTS OR EXCESS PARTS.</p> <p>(4)THE JUMPER ON THE PCB SHOULD CONFORM TO THE PRODUCT CHARACTERISTIC CHART.</p> <p>(5)IF SOLDER GETS ON BEZEL TAB PADS, LED PAD, ZEBRA PAD OR SCREW HOLD PAD; MAKE SURE IT IS SMOOTHED DOWN.</p>		

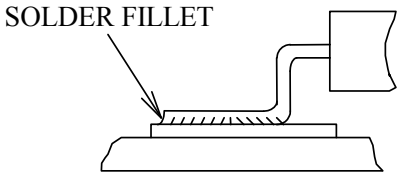
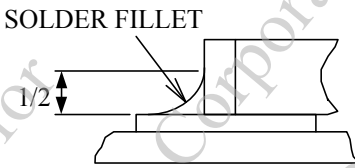
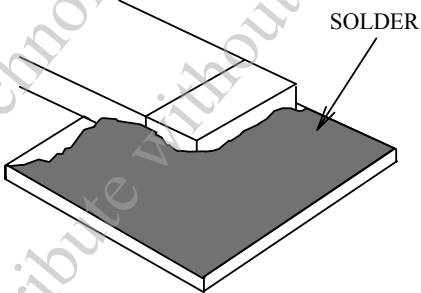
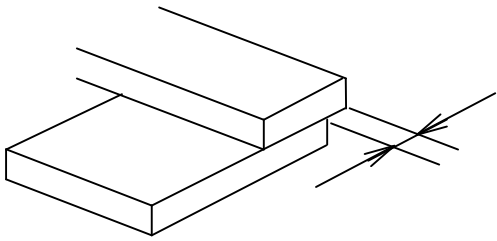
NO.	ITEM	CRITERIA
12	SOLDERING	<p>(1)NO SOLDERING FOUND ON THE SPECIFIED PLACE</p> <p>(2)INSUFFICIENT SOLDER</p> <p>(a)LSI, IC A POOR WETTING OF SOLDER IS BETWEEN LOWER BEND OR "HEEL" OF LEAD AND PAD</p>  <p>(b)CHIP COMPONENT</p> <ul style="list-style-type: none"> · SOLDER IS LESS THAN 50% OF SIDES AND FRONT FACE WETTING  <ul style="list-style-type: none"> · SOLDER WETS 3 SIDES OF TERMINAL, BUT LESS THAN 25% OF SIDES AND FRONT SURFACE AREA ARE COVERED  <p>(3)PARTS ALIGNMENT</p> <p>(a)LSI, IC LEAD WIDTH IS MORE THAN 50% BEYOND PAD OUTLINE</p> 

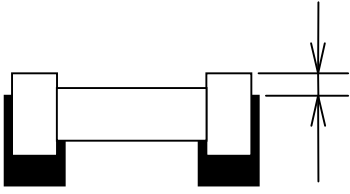
NO.	ITEM	CRITERIA
12	SOLDERING	<p>(b)CHIP COMPONENT COMPONENT IS OFF CENTER, AND MORE THAN 50% OF THE LEADS IS OFF THE PAD OUTLINE</p>  <p>(4)NO UNMELTED SOLDER PASTE MAY BE PRESENT ON THE PCB. (5)NO COLD SOLDER JOINTS, MISSING SOLDER CONNECTIONS, OXIDATION OR ICICLE. (6)NO RESIDUE OR SOLDER BALLS ON PCB. (7)NO SHORT CIRCUITS IN COMPONENTS ON PCB.</p>
13	BACKLIGHT	<p>(1)NO LIGHT (2)FLICKERING AND OTHER ABNORMAL ILLUMINATION (3)SPOTS OR SCRATCHES THAT APPEAR WHEN LIT MUST BE JUDGED USING LCD SPOT, LINES AND CONTAMINATION STANDARDS. (4)BACKLIGHT DOESN'T LIGHT OR COLOR IS WRONG.</p>
14	GENERAL APPEARANCE	<p>(1)NO OXIDATION, CONTAMINATION, CURVES OR, BENDS ON INTERFACE PIN (OLB) OF TCP. (2)NO CRACKS ON INTERFACE PIN (OLB) OF TCP. (3)NO CONTAMINATION, SOLDER RESIDUE OR SOLDER BALLS ON PRODUCT. (4)THE IC ON THE TCP MAY NOT BE DAMAGED, CIRCUITS. (5)THE UPPERMOST EDGE OF THE PROTECTIVE STRIP ON THE INTERFACE PIN MUST BE PRESENT OR LOOK AS IF IT CAUSE THE INTERFACE PIN TO SEVER. (6)THE RESIDUAL ROSIN OR TIN OIL OF SOLDERING (COMPONENT OR CHIP COMPONENT) IS NOT BURNED INTO BROWN OR BLACK COLOR. (7)SEALANT ON TOP OF THE ITO CIRCUIT HAS NOT HARDENED. (8)PIN TYPE MUST MATCH TYPE IN SPECIFICATION SHEET. (9)LCD PIN LOOSE OR MISSING PINS. (10)PRODUCT PACKAGING MUST THE SAME AS SPECIFIED ON PACKAGING SPECIFICATION SHEET. (11)PRODUCT DIMENSION AND STRUCTURE MUST CONFORM TO PRODUCT SPECIFICATION SHEET. (12)THE APPEARANCE OF HEAT SEAL SHOULD NOT ADMIT ANY DIRT AND BREAK.</p>

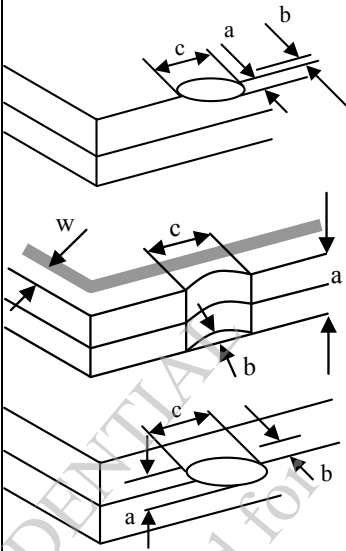
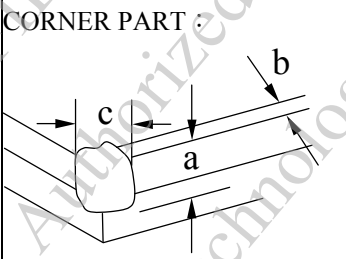
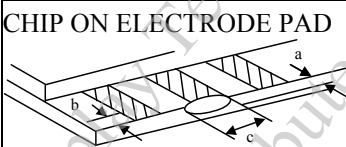
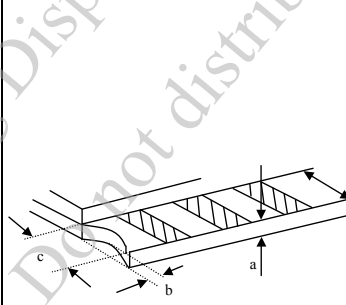
NO.	ITEM	CRITERIA									
15	CRACKED GLASS	<p>THE LCD WITH EXTENSIVE CRACK IS NOT ACCEPTABLE</p> <p>GENERAL GLASS CHIP :</p>  <table border="1"> <thead> <tr> <th>a</th> <th>b</th> <th>c</th> </tr> </thead> <tbody> <tr> <td>$\leq t/2$</td> <td>< VIEWING AREA</td> <td>$\leq 1/8X$</td> </tr> <tr> <td>$t/2 > , \leq 2t$</td> <td>$\leq W/2$</td> <td>$\leq 1/8X$</td> </tr> </tbody> </table> <p>*W=DISTANCE BETWEEN SEALANT AREA AND LCD PANEL EDGE X = LCD SIDE LENGTH t = GLASS THICKNESS</p>	a	b	c	$\leq t/2$	< VIEWING AREA	$\leq 1/8X$	$t/2 > , \leq 2t$	$\leq W/2$	$\leq 1/8X$
		a	b	c							
		$\leq t/2$	< VIEWING AREA	$\leq 1/8X$							
		$t/2 > , \leq 2t$	$\leq W/2$	$\leq 1/8X$							
<p>CORNER PART :</p>  <table border="1"> <thead> <tr> <th>a</th> <th>b</th> <th>c</th> </tr> </thead> <tbody> <tr> <td>$\leq t/2$</td> <td>< VIEWING AREA</td> <td>$\leq 1/8X$</td> </tr> <tr> <td>$> t/2 , \leq 2t$</td> <td>$\leq W/2$</td> <td>$\leq 1/8X$</td> </tr> </tbody> </table> <p>*W=DISTANCE BETWEEN SEALANT AREA AND LCD PANEL EDGE X = LCD SIDE LENGTH t = GLASS THICKNESS</p>	a	b	c	$\leq t/2$	< VIEWING AREA	$\leq 1/8X$	$> t/2 , \leq 2t$	$\leq W/2$	$\leq 1/8X$		
a	b	c									
$\leq t/2$	< VIEWING AREA	$\leq 1/8X$									
$> t/2 , \leq 2t$	$\leq W/2$	$\leq 1/8X$									
<p>CHIP ON ELECTRODE PAD</p>  <table border="1"> <thead> <tr> <th>a</th> <th>b</th> <th>c</th> </tr> </thead> <tbody> <tr> <td>$\leq t$</td> <td>$\leq 0.5\text{mm}$</td> <td>$\leq 1/8X$</td> </tr> </tbody> </table> <p>* X=LCD SIDE WIDTH t=GLASS THICKNESS</p>	a	b	c	$\leq t$	$\leq 0.5\text{mm}$	$\leq 1/8X$					
a	b	c									
$\leq t$	$\leq 0.5\text{mm}$	$\leq 1/8X$									
 <table border="1"> <thead> <tr> <th>a</th> <th>b</th> <th>c</th> </tr> </thead> <tbody> <tr> <td>$\leq t$</td> <td>$\leq 1/8X$</td> <td>$\leq L$</td> </tr> </tbody> </table> <p>*X=LCD SIDE WIDTH t = GLASS THICKNESS L=ELECTRODE PAD LENGTH ①IF GLASS CHIPPING THE ITO TERMINAL, OVER 2/3 OF THE ITO MUST REMAIN AND BE, INSPECTED ACCORDING TO ELECTRODE TERMINAL SPECIFICATIONS ②IF THE PRODUCT WILL BE HEAT SEALED BY THE CUSTOMER, THE ALIGNMENT MARK MUST NOT BE DAMAGED</p>	a	b	c	$\leq t$	$\leq 1/8X$	$\leq L$					
a	b	c									
$\leq t$	$\leq 1/8X$	$\leq L$									

12.4 RELIABILITY TEST

12.4.1 STANDARD SPECIFICATIONS FOR RELIABILITY OF LCD MODULE

NO.	ITEM	DESCRIPTION
1	HIGH TEMPERATURE OPERATION	THE SAMPLE SHOULD BE ALLOWED TO STAND AT +80°C FOR 240 HRS
2	LOW TEMPERATURE OPERATION	THE SAMPLE SHOULD BE ALLOWED TO STAND AT -30°C FOR 240 HRS
3	HIGH TEMPERATURE STORAGE	THE SAMPLE SHOULD BE ALLOWED TO STAND AT +80°C FOR 240 HRS
4	LOW TEMPERATURE STORAGE	THE SAMPLE SHOULD BE ALLOWED TO STAND AT -30°C FOR 240 HRS
5	HIGH TEMPERATURE / HUMIDITY TEST STORAGE	THE SAMPLE SHOULD BE ALLOWED TO STAND AT 60°C, 90% RH 240 HRS
6	THERMAL SHOCK (NOT OPERATED)	<p>THE SAMPLE SHOULD BE ALLOWED TO STAND THE FOLLOWING 10 CYCLES OF OPERATION:</p> <p>The diagram shows a temperature profile for one cycle of thermal shock testing. It starts at -30°C, ramps up to +80°C (30 min), stays at +80°C (3 min), ramps down to -30°C (30 min), and stays at -30°C (3 min). The total duration of one cycle is 108 minutes.</p>
7	ESD (ELECTROSTATIC DISCHARGE) (NOT OPERATED)	AIR DISCHARGE ± 12KV CONTACT DISCHARGE ± 8KV (ACCORDING TO IEC-61000-4-2)

NOTE (1) : THE TEST SAMPLES HAVE RECOVERY TIME FOR 2 HOURS AT ROOM TEMPERATURE BEFORE THE FUNCTION CHECK. IN THE STANDARD CONDITIONS, THERE IS NO DISPLAY FUNCTION NG ISSUE OCCURRED.

12.5 TESTING CONDITIONS AND INSPECTION CRITERIA

FOR THE FINAL TEST THE TESTING SAMPLE MUST BE STORED AT ROOM TEMPERATURE FOR 24 HOURS, AFTER THE TESTS LISTED IN TABLE 12.5, STANDARD SPECIFICATIONS FOR RELIABILITY HAVE BEEN EXECUTED IN ORDER TO ENSURE STABILITY.

NO.	ITEM	TEST MODEL	INSPECTION CRITERIA
1	CURRENT CONSUMPTION	REFER TO SPECIFICATION	THE CURRENT CONSUMPTION SHOULD CONFORM TO THE PRODUCT SPECIFICATION.
2	CONTRAST	REFER TO SPECIFICATION	AFTER THE TESTS HAVE BEEN EXECUTED, THE CONTRAST MUST BE LARGER THAN HALF OF ITS INITIAL VALUE PRIOR TO THE TESTS.
3	APPEARANCE	VISUAL INSPECTION	DEFECT FREE

12.6 OPERATION

- 12.6.1 DO NOT CONNECT OR DISCONNECT MODULES TO OR FROM THE MAIN SYSTEM WHILE POWER IS BEING SUPPLIED .
- 12.6.2 USE THE MODULE WITHIN SPECIFIED TEMPERATURE ; LOWER TEMPERATURE CAUSES THE RETARDATION OF BLINKING SPEED OF THE DISPLAY ; HIGHER TEMPERATURE MAKES OVERALL DISPLAY DISCOLOR . WHEN THE TEMPERATURE RETURNS TO NORMALITY, THE DISPLAY WILL OPERATE NORMALLY.
- 12.6.3 ADJUST THE LC DRIVING VOLTAGE TO OBTAIN THE OPTIMUM CONTRAST .
- 12.6.4 POWER ON SEQUENCE INPUT SIGNALS SHOULD NOT BE SUPPLIED TO LCD MODULE BEFORE POWER SUPPLY VOLTAGE IS APPLIED AND REACHES THE SPECIFIED VALUE.
IF ABOVE SEQUENCE IS NOT FOLLOWED , CMOS LSIS OF LCD MODULES MAY BE DAMAGED DUE TO LATCH - UP PROBLEM.
- 12.6.5 NOT ALLOWED TO INFLICT ANY EXTERNAL STRESS AND TO CAUSE ANY MECHANICAL INTERFERENCE ON THE BENDING AREA OF FPC DURING THE TAIL BENDING BACKWARDS!
DO NOT STRESS FPC AND IC ON THE MODULE!

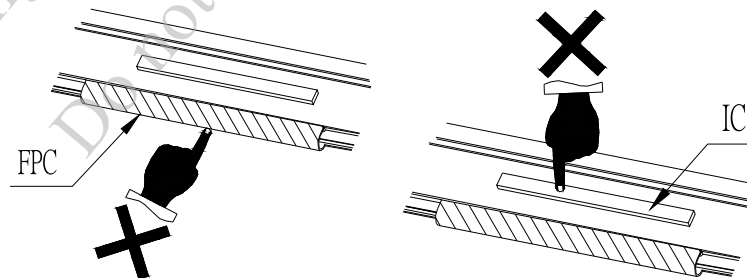

12.7 NOTICE

- 12.7.1 USE A GROUNDED SOLDERING IRON WHEN SOLDERING CONNECTOR I/O TERMINALS . FOR SOLDERING OR REPAIRING, TAKE PRECAUTION AGAINST THE TEMPERATURE OF THE SOLDERING IRON AND THE SOLDERING TIME TO PREVENT PEELING OFF THE THROUGH-HOLE-PAD .
- 12.7.2 DO NOT DISASSEMBLE . EDT SHALL NOT BE HELD RESPONSIBLE IF THE MODULE IS DISASSEMBLED AND UPON THE REASSEMBLY THE MODULE FAILED.
- 12.7.3 DO NOT CHARGE STATIC ELECTRICITY, AS THE CIRCUIT OF THIS MODULE CONTAINS CMOS LSIS. A WORKMAN'S BODY SHOULD ALWAYS BE STATIC-PROTECTED BY USE OF AN ESD STRAP. WORKING CLOTHES FOR SUCH PERSONNEL SHOULD BE OF STATIC-PROTECTED MATERIAL.
- 12.7.4 ALWAYS GROUND THE ELECTRICALLY-POWERED DRIVER BEFORE USING IT TO INSTALL THE LCD MODULE. WHILE CLEANING THE WORK STATION BY VACUUM CLEANER, DO NOT BRING THE SUCKING MOUTH NEAR THE MODULE ; STATIC ELECTRICITY OF THE ELECTRICALLY-POWERED DRIVER OR THE VACUUM CLEANER MAY DESTROY THE MODULE.
- 12.7.5 DON'T GIVE EXTERNAL SHOCK.
- 12.7.6 DON'T APPLY EXCESSIVE FORCE ON THE SURFACE.
- 12.7.7 LIQUID IN LCD IS HAZARDOUS SUBSTANCE. MUST NOT LICK AND SWALLOW.
WHEN THE LIQUID IS ATTACH TO YOUR, SKIN, CLOTH ETC. WASH IT OUT THOROUGHLY AND IMMEDIATELY
- 12.7.8 DON'T OPERATE IT ABOVE THE ABSOLUTE MAXIMUM RATING.
- 12.7.9 STORAGE IN A CLEAN ENVIRONMENT, FREE FROM DUST, ACTIVE GAS, AND SOLVENT.
- 12.7.10 STORE WITHOUT ANY PHYSICAL LOAD.
- 12.7.11 REWIRING: NO MORE THAN 3 TIMES.