

EXAMINED BY :	EMERGING DISPLAY TECHNOLOGIES CORPORATION	FILE NO . CAS-0008750
Sam Chou		ISSUE : JUN.25, 2019
APPROVED BY:		TOTAL PAGE : 32
<i>Chris Wu</i>		VERSION : 3

CUSTOMER ACCEPTANCE SPECIFICATIONS

MODEL NO. :

ETM035013EDHA

(RoHS)

FOR MESSRS : _____

CUSTOMER'S APPROVAL

DATE :

BY :

DOC . FIRST ISSUE

RECORDS OF REVISION

JAN.15, 2019

DATE	REVISED PAGE NO.	SUMMARY																																																																																																																																																																
APR.16, 2019	15	8.1 TFT MODIFY SCL→SCK, SDA→SDI, SDA→SDO																																																																																																																																																																
	17	10.1 LCD MODULE <table border="1"> <tr> <td>PIN NO.</td> <td>SYMBOL</td> <td>PIN NO.</td> <td>SYMBOL</td> </tr> <tr> <td>8</td> <td>SCL</td> <td>8</td> <td>SCK</td> </tr> <tr> <td>9</td> <td>SDA</td> <td>9</td> <td>SDI</td> </tr> <tr> <td>10</td> <td>SDA</td> <td>10</td> <td>SDO</td> </tr> </table>	PIN NO.	SYMBOL	PIN NO.	SYMBOL	8	SCL	8	SCK	9	SDA	9	SDI	10	SDA	10	SDO																																																																																																																																																
PIN NO.	SYMBOL	PIN NO.	SYMBOL																																																																																																																																																															
8	SCL	8	SCK																																																																																																																																																															
9	SDA	9	SDI																																																																																																																																																															
10	SDA	10	SDO																																																																																																																																																															
JUN.25, 2019	3	3.1 ELECTRICAL ABSOLUTE MAXIMUM RATINGS <table border="1"> <thead> <tr> <th>ITEM</th> <th>SYMBOL</th> <th>MIN.</th> <th>MAX.</th> <th>UNIT</th> <th>REMARK</th> </tr> </thead> <tbody> <tr> <td>POWER SUPPLY VOLTAGE</td> <td>VDD</td> <td>-0.3</td> <td>4</td> <td>V</td> <td>—</td> </tr> <tr> <td>IO SUPPLY VOLTAGE</td> <td>VDDI</td> <td>-0.3</td> <td>4</td> <td>V</td> <td>—</td> </tr> <tr> <td>STATIC ELECTRICITY</td> <td>—</td> <td>—</td> <td>—</td> <td>V</td> <td>NOTE (1)</td> </tr> <tr> <td>LED BACKLIGHT POWER DISSIPATION</td> <td>PD</td> <td>—</td> <td>465</td> <td>mW</td> <td>—</td> </tr> <tr> <td>LED BACKLIGHT FORWARD CURRENT</td> <td>ILED</td> <td>—</td> <td>30</td> <td>mA</td> <td>—</td> </tr> <tr> <td>LED BACKLIGHT REVERSE VOLTAGE</td> <td>VR</td> <td>—</td> <td>30</td> <td>V</td> <td>—</td> </tr> </tbody> </table> <table border="1"> <thead> <tr> <th>ITEM</th> <th>SYMBOL</th> <th>MIN.</th> <th>MAX.</th> <th>UNIT</th> <th>REMARK</th> </tr> </thead> <tbody> <tr> <td>POWER SUPPLY VOLTAGE</td> <td>VDD-VSS</td> <td>-0.3</td> <td>4</td> <td>V</td> <td>—</td> </tr> <tr> <td>STATIC ELECTRICITY</td> <td>—</td> <td>—</td> <td>—</td> <td>V</td> <td>NOTE (1)</td> </tr> <tr> <td>POWER DISSIPATION FOR LED BACKLIGHT</td> <td>PD</td> <td>—</td> <td>465</td> <td>mW</td> <td>—</td> </tr> <tr> <td>FORWARD CURRENT FOR LED BACKLIGHT</td> <td>ILED</td> <td>—</td> <td>30</td> <td>mA</td> <td>—</td> </tr> <tr> <td>REVERSE VOLTAGE FOR LED BACKLIGHT</td> <td>VR</td> <td>—</td> <td>30</td> <td>V</td> <td>—</td> </tr> </tbody> </table> <p>NOTE (1) : LCM SHOULD BE GROUND DURING HANDLING LCM.→ LCM SHOULD BE GROUND DURING LCM HANDLING.</p>	ITEM	SYMBOL	MIN.	MAX.	UNIT	REMARK	POWER SUPPLY VOLTAGE	VDD	-0.3	4	V	—	IO SUPPLY VOLTAGE	VDDI	-0.3	4	V	—	STATIC ELECTRICITY	—	—	—	V	NOTE (1)	LED BACKLIGHT POWER DISSIPATION	PD	—	465	mW	—	LED BACKLIGHT FORWARD CURRENT	ILED	—	30	mA	—	LED BACKLIGHT REVERSE VOLTAGE	VR	—	30	V	—	ITEM	SYMBOL	MIN.	MAX.	UNIT	REMARK	POWER SUPPLY VOLTAGE	VDD-VSS	-0.3	4	V	—	STATIC ELECTRICITY	—	—	—	V	NOTE (1)	POWER DISSIPATION FOR LED BACKLIGHT	PD	—	465	mW	—	FORWARD CURRENT FOR LED BACKLIGHT	ILED	—	30	mA	—	REVERSE VOLTAGE FOR LED BACKLIGHT	VR	—	30	V	—																																																																																		
		ITEM	SYMBOL	MIN.	MAX.	UNIT	REMARK																																																																																																																																																											
		POWER SUPPLY VOLTAGE	VDD	-0.3	4	V	—																																																																																																																																																											
IO SUPPLY VOLTAGE	VDDI	-0.3	4	V	—																																																																																																																																																													
STATIC ELECTRICITY	—	—	—	V	NOTE (1)																																																																																																																																																													
LED BACKLIGHT POWER DISSIPATION	PD	—	465	mW	—																																																																																																																																																													
LED BACKLIGHT FORWARD CURRENT	ILED	—	30	mA	—																																																																																																																																																													
LED BACKLIGHT REVERSE VOLTAGE	VR	—	30	V	—																																																																																																																																																													
ITEM	SYMBOL	MIN.	MAX.	UNIT	REMARK																																																																																																																																																													
POWER SUPPLY VOLTAGE	VDD-VSS	-0.3	4	V	—																																																																																																																																																													
STATIC ELECTRICITY	—	—	—	V	NOTE (1)																																																																																																																																																													
POWER DISSIPATION FOR LED BACKLIGHT	PD	—	465	mW	—																																																																																																																																																													
FORWARD CURRENT FOR LED BACKLIGHT	ILED	—	30	mA	—																																																																																																																																																													
REVERSE VOLTAGE FOR LED BACKLIGHT	VR	—	30	V	—																																																																																																																																																													
3.2 CAPACITIVE TOUCH PANEL ELECTRICAL ABSOLUTE MAXIMUM RATINGS PARAMETER: POWER SUPPLY FOR DRIVER→POWER SUPPLY VOLTAGE																																																																																																																																																																		
3.3 ENVIRONMENTAL ABSOLUTE MAXIMUM RATINGS <table border="1"> <thead> <tr> <th rowspan="2">ITEM</th> <th colspan="2">STORAGE</th> <th rowspan="2">REMARK</th> <th rowspan="2">ITEM</th> <th colspan="2">STORAGE</th> <th rowspan="2">REMARK</th> </tr> <tr> <th>MIN.</th> <th>MAX.</th> <th>MIN.</th> <th>MAX.</th> </tr> </thead> <tbody> <tr> <td>VIBRATION</td> <td>—</td> <td>11.76ms² (1.2G)</td> <td>5-20Hz : 1HR 20-500Hz(20Hz) : 1HR 20-500Hz(500Hz) : 1HR X,Y,Z.TOTAL : 3HRS</td> <td>VIBRATION</td> <td>—</td> <td>11.76ms² (1.2G)</td> <td>10-100 Hz XYZ DIRECTIONS 1HR EACH</td> </tr> <tr> <td>SHOCK</td> <td>—</td> <td>490ms² (50G)</td> <td>10 ms XYZ DIRECTIONS 1 TIME EACH</td> <td>SHOCK</td> <td>—</td> <td>490.0ms² (50G)</td> <td>10 ms XYZ DIRECTIONS 1 TIME EACH</td> </tr> </tbody> </table>	ITEM	STORAGE		REMARK	ITEM	STORAGE		REMARK	MIN.	MAX.	MIN.	MAX.	VIBRATION	—	11.76ms ² (1.2G)	5-20Hz : 1HR 20-500Hz(20Hz) : 1HR 20-500Hz(500Hz) : 1HR X,Y,Z.TOTAL : 3HRS	VIBRATION	—	11.76ms ² (1.2G)	10-100 Hz XYZ DIRECTIONS 1HR EACH	SHOCK	—	490ms ² (50G)	10 ms XYZ DIRECTIONS 1 TIME EACH	SHOCK	—	490.0ms ² (50G)	10 ms XYZ DIRECTIONS 1 TIME EACH																																																																																																																																						
ITEM		STORAGE				REMARK	ITEM		STORAGE		REMARK																																																																																																																																																							
	MIN.	MAX.	MIN.	MAX.																																																																																																																																																														
VIBRATION	—	11.76ms ² (1.2G)	5-20Hz : 1HR 20-500Hz(20Hz) : 1HR 20-500Hz(500Hz) : 1HR X,Y,Z.TOTAL : 3HRS	VIBRATION	—	11.76ms ² (1.2G)	10-100 Hz XYZ DIRECTIONS 1HR EACH																																																																																																																																																											
SHOCK	—	490ms ² (50G)	10 ms XYZ DIRECTIONS 1 TIME EACH	SHOCK	—	490.0ms ² (50G)	10 ms XYZ DIRECTIONS 1 TIME EACH																																																																																																																																																											
4	4	4.1 TFT MODULE ELECTRICAL CHARACTERISTICS <table border="1"> <thead> <tr> <th>ITEM</th> <th>SYMBOL</th> <th>CONDITION</th> <th>MIN.</th> <th>TYP.</th> <th>MAX.</th> <th>UNIT</th> <th>REMARK</th> </tr> </thead> <tbody> <tr> <td>ANALOG POWER SUPPLY</td> <td>VDD</td> <td>—</td> <td>3.0</td> <td>3.3</td> <td>3.6</td> <td>V</td> <td>—</td> </tr> <tr> <td>DIGITAL POWER SUPPLY</td> <td>VDDI</td> <td>—</td> <td>3.0</td> <td>3.3</td> <td>3.6</td> <td>V</td> <td>—</td> </tr> <tr> <td>LOGIC HIGH INPUT VOLTAGE</td> <td>V_{IH}</td> <td>H LEVEL</td> <td>0.7VDD</td> <td>—</td> <td>—</td> <td>V</td> <td>NOTE (1)</td> </tr> <tr> <td>LOGIC LOW INPUT VOLTAGE</td> <td>V_{IL}</td> <td>L LEVEL</td> <td>—</td> <td>—</td> <td>0.3VDD</td> <td>V</td> <td>NOTE (1)</td> </tr> <tr> <td>LOGIC HIGH OUTPUT VOLTAGE</td> <td>V_{OH}</td> <td>I_{OL}=-1.0mA</td> <td>VDDI-0.4</td> <td>—</td> <td>VDDI</td> <td>V</td> <td>—</td> </tr> <tr> <td>LOGIC LOW OUTPUT VOLTAGE</td> <td>V_{OL}</td> <td>I_{OL}=-1.0mA</td> <td>VSS</td> <td>—</td> <td>VSS+0.4</td> <td>V</td> <td>—</td> </tr> <tr> <td>ANALOG OPERATING CURRENT</td> <td>IDD</td> <td>VDD=3.3V</td> <td>—</td> <td>20</td> <td>30</td> <td>mA</td> <td>NOTE (2)</td> </tr> <tr> <td>DIGITAL OPERATING CURRENT</td> <td>IDDI</td> <td>VDDI=3.3V</td> <td>—</td> <td>1</td> <td>2</td> <td>mA</td> <td>NOTE (2)</td> </tr> <tr> <td>POWER SUPPLY FOR LED BACKLIGHT</td> <td>VLED-VLSS</td> <td>ILED=20mA</td> <td>—</td> <td>18.0</td> <td>18.6</td> <td>V</td> <td>NOTE (1)</td> </tr> <tr> <td>LED LIFE TIME</td> <td>—</td> <td>ILED=20mA</td> <td>30K</td> <td>40K</td> <td>—</td> <td>HRS</td> <td>NOTE (5) NOTE (6)</td> </tr> </tbody> </table> <table border="1"> <thead> <tr> <th>ITEM</th> <th>SYMBOL</th> <th>CONDITION</th> <th>MIN.</th> <th>TYP.</th> <th>MAX.</th> <th>UNIT</th> <th>REMARK</th> </tr> </thead> <tbody> <tr> <td>POWER SUPPLY VOLTAGE</td> <td>VDD-VSS</td> <td>—</td> <td>3.0</td> <td>3.3</td> <td>3.6</td> <td>V</td> <td>—</td> </tr> <tr> <td>LOGIC HIGH INPUT VOLTAGE</td> <td>V_{IH}</td> <td>—</td> <td>0.7VDD</td> <td>—</td> <td>—</td> <td>V</td> <td>NOTE (1)</td> </tr> <tr> <td>LOGIC LOW INPUT VOLTAGE</td> <td>V_{IL}</td> <td>—</td> <td>—</td> <td>—</td> <td>0.3VDD</td> <td>V</td> <td>NOTE (1)</td> </tr> <tr> <td>LOGIC HIGH OUTPUT VOLTAGE</td> <td>V_{OH}</td> <td>I_{OH}=-1.0mA</td> <td>VDD-0.4</td> <td>—</td> <td>VDD</td> <td>V</td> <td>—</td> </tr> <tr> <td>LOGIC LOW OUTPUT VOLTAGE</td> <td>V_{OL}</td> <td>I_{OL}=-1.0mA</td> <td>VSS</td> <td>—</td> <td>VSS+0.4</td> <td>V</td> <td>—</td> </tr> <tr> <td>POWER SUPPLY CURRENT</td> <td>IDD</td> <td>VDD-VSS=3.3V</td> <td>—</td> <td>20</td> <td>30</td> <td>mA</td> <td>NOTE (2)</td> </tr> <tr> <td>POWER SUPPLY VOLTAGE FOR LED BACKLIGHT</td> <td>VLED-VLSS</td> <td>ILED=20mA</td> <td>—</td> <td>18.0</td> <td>18.6</td> <td>V</td> <td>NOTE (1)</td> </tr> <tr> <td>LED LIFE TIME</td> <td>—</td> <td>IF=20mA (PER LED)</td> <td>30K</td> <td>40K</td> <td>—</td> <td>HRS</td> <td>NOTE (5) NOTE (6)</td> </tr> </tbody> </table> <p>NOTE (5) : TA=25 °C→Ta=25 °C</p>	ITEM	SYMBOL	CONDITION	MIN.	TYP.	MAX.	UNIT	REMARK	ANALOG POWER SUPPLY	VDD	—	3.0	3.3	3.6	V	—	DIGITAL POWER SUPPLY	VDDI	—	3.0	3.3	3.6	V	—	LOGIC HIGH INPUT VOLTAGE	V _{IH}	H LEVEL	0.7VDD	—	—	V	NOTE (1)	LOGIC LOW INPUT VOLTAGE	V _{IL}	L LEVEL	—	—	0.3VDD	V	NOTE (1)	LOGIC HIGH OUTPUT VOLTAGE	V _{OH}	I _{OL} =-1.0mA	VDDI-0.4	—	VDDI	V	—	LOGIC LOW OUTPUT VOLTAGE	V _{OL}	I _{OL} =-1.0mA	VSS	—	VSS+0.4	V	—	ANALOG OPERATING CURRENT	IDD	VDD=3.3V	—	20	30	mA	NOTE (2)	DIGITAL OPERATING CURRENT	IDDI	VDDI=3.3V	—	1	2	mA	NOTE (2)	POWER SUPPLY FOR LED BACKLIGHT	VLED-VLSS	ILED=20mA	—	18.0	18.6	V	NOTE (1)	LED LIFE TIME	—	ILED=20mA	30K	40K	—	HRS	NOTE (5) NOTE (6)	ITEM	SYMBOL	CONDITION	MIN.	TYP.	MAX.	UNIT	REMARK	POWER SUPPLY VOLTAGE	VDD-VSS	—	3.0	3.3	3.6	V	—	LOGIC HIGH INPUT VOLTAGE	V _{IH}	—	0.7VDD	—	—	V	NOTE (1)	LOGIC LOW INPUT VOLTAGE	V _{IL}	—	—	—	0.3VDD	V	NOTE (1)	LOGIC HIGH OUTPUT VOLTAGE	V _{OH}	I _{OH} =-1.0mA	VDD-0.4	—	VDD	V	—	LOGIC LOW OUTPUT VOLTAGE	V _{OL}	I _{OL} =-1.0mA	VSS	—	VSS+0.4	V	—	POWER SUPPLY CURRENT	IDD	VDD-VSS=3.3V	—	20	30	mA	NOTE (2)	POWER SUPPLY VOLTAGE FOR LED BACKLIGHT	VLED-VLSS	ILED=20mA	—	18.0	18.6	V	NOTE (1)	LED LIFE TIME	—	IF=20mA (PER LED)	30K	40K	—	HRS	NOTE (5) NOTE (6)
		ITEM	SYMBOL	CONDITION	MIN.	TYP.	MAX.	UNIT	REMARK																																																																																																																																																									
ANALOG POWER SUPPLY	VDD	—	3.0	3.3	3.6	V	—																																																																																																																																																											
DIGITAL POWER SUPPLY	VDDI	—	3.0	3.3	3.6	V	—																																																																																																																																																											
LOGIC HIGH INPUT VOLTAGE	V _{IH}	H LEVEL	0.7VDD	—	—	V	NOTE (1)																																																																																																																																																											
LOGIC LOW INPUT VOLTAGE	V _{IL}	L LEVEL	—	—	0.3VDD	V	NOTE (1)																																																																																																																																																											
LOGIC HIGH OUTPUT VOLTAGE	V _{OH}	I _{OL} =-1.0mA	VDDI-0.4	—	VDDI	V	—																																																																																																																																																											
LOGIC LOW OUTPUT VOLTAGE	V _{OL}	I _{OL} =-1.0mA	VSS	—	VSS+0.4	V	—																																																																																																																																																											
ANALOG OPERATING CURRENT	IDD	VDD=3.3V	—	20	30	mA	NOTE (2)																																																																																																																																																											
DIGITAL OPERATING CURRENT	IDDI	VDDI=3.3V	—	1	2	mA	NOTE (2)																																																																																																																																																											
POWER SUPPLY FOR LED BACKLIGHT	VLED-VLSS	ILED=20mA	—	18.0	18.6	V	NOTE (1)																																																																																																																																																											
LED LIFE TIME	—	ILED=20mA	30K	40K	—	HRS	NOTE (5) NOTE (6)																																																																																																																																																											
ITEM	SYMBOL	CONDITION	MIN.	TYP.	MAX.	UNIT	REMARK																																																																																																																																																											
POWER SUPPLY VOLTAGE	VDD-VSS	—	3.0	3.3	3.6	V	—																																																																																																																																																											
LOGIC HIGH INPUT VOLTAGE	V _{IH}	—	0.7VDD	—	—	V	NOTE (1)																																																																																																																																																											
LOGIC LOW INPUT VOLTAGE	V _{IL}	—	—	—	0.3VDD	V	NOTE (1)																																																																																																																																																											
LOGIC HIGH OUTPUT VOLTAGE	V _{OH}	I _{OH} =-1.0mA	VDD-0.4	—	VDD	V	—																																																																																																																																																											
LOGIC LOW OUTPUT VOLTAGE	V _{OL}	I _{OL} =-1.0mA	VSS	—	VSS+0.4	V	—																																																																																																																																																											
POWER SUPPLY CURRENT	IDD	VDD-VSS=3.3V	—	20	30	mA	NOTE (2)																																																																																																																																																											
POWER SUPPLY VOLTAGE FOR LED BACKLIGHT	VLED-VLSS	ILED=20mA	—	18.0	18.6	V	NOTE (1)																																																																																																																																																											
LED LIFE TIME	—	IF=20mA (PER LED)	30K	40K	—	HRS	NOTE (5) NOTE (6)																																																																																																																																																											
5	5	4.2 CAPACITIVE TOUCH PANEL ELECTRICAL CHARACTERISTICS <table border="1"> <thead> <tr> <th>ITEM</th> <th>ITEM</th> </tr> </thead> <tbody> <tr> <td>POWER SUPPLY FOR DRIVER</td> <td>POWER SUPPLY VOLTAGE</td> </tr> <tr> <td>INPUT HIGH LEVEL VOLTAGE</td> <td>LOGIC HIGH INPUT VOLTAGE</td> </tr> <tr> <td>INPUT LOW LEVEL VOLTAGE</td> <td>LOGIC LOW INPUT VOLTAGE</td> </tr> <tr> <td>OUTPUT HIGH LEVEL VOLTAGE</td> <td>LOGIC HIGH OUTPUT VOLTAGE</td> </tr> <tr> <td>OUTPUT LOW LEVEL VOLTAGE</td> <td>LOGIC LOW OUTPUT VOLTAGE</td> </tr> <tr> <td>POWER SUPPLY CURRENT CONSUMPTION FOR OPERATION</td> <td>POWER SUPPLY CURRENT</td> </tr> </tbody> </table>	ITEM	ITEM	POWER SUPPLY FOR DRIVER	POWER SUPPLY VOLTAGE	INPUT HIGH LEVEL VOLTAGE	LOGIC HIGH INPUT VOLTAGE	INPUT LOW LEVEL VOLTAGE	LOGIC LOW INPUT VOLTAGE	OUTPUT HIGH LEVEL VOLTAGE	LOGIC HIGH OUTPUT VOLTAGE	OUTPUT LOW LEVEL VOLTAGE	LOGIC LOW OUTPUT VOLTAGE	POWER SUPPLY CURRENT CONSUMPTION FOR OPERATION	POWER SUPPLY CURRENT																																																																																																																																																		
ITEM	ITEM																																																																																																																																																																	
POWER SUPPLY FOR DRIVER	POWER SUPPLY VOLTAGE																																																																																																																																																																	
INPUT HIGH LEVEL VOLTAGE	LOGIC HIGH INPUT VOLTAGE																																																																																																																																																																	
INPUT LOW LEVEL VOLTAGE	LOGIC LOW INPUT VOLTAGE																																																																																																																																																																	
OUTPUT HIGH LEVEL VOLTAGE	LOGIC HIGH OUTPUT VOLTAGE																																																																																																																																																																	
OUTPUT LOW LEVEL VOLTAGE	LOGIC LOW OUTPUT VOLTAGE																																																																																																																																																																	
POWER SUPPLY CURRENT CONSUMPTION FOR OPERATION	POWER SUPPLY CURRENT																																																																																																																																																																	

RECORDS OF REVISION	DOC . FIRST ISSUE	JAN.15, 2019
---------------------	-------------------	--------------

DATE	REVISED PAGE NO.	SUMMARY																															
JUN.25, 2019	12	6.1 OPTICAL CHARACTERISTICS <table border="1"> <thead> <tr> <th>ITEM</th> <th>MIN.</th> <th>TYP.</th> <th>MAX.</th> </tr> </thead> <tbody> <tr> <td>COLOR OF CIE COORDINATE (CENTER)</td> <td>0.28</td> <td>0.33</td> <td>0.38</td> </tr> <tr> <td>WHITE</td> <td>0.30</td> <td>0.35</td> <td>0.40</td> </tr> </tbody> </table> <table border="1"> <thead> <tr> <th>ITEM</th> <th>MIN.</th> <th>TYP.</th> <th>MAX.</th> </tr> </thead> <tbody> <tr> <td>COLOR OF CIE COORDINATE (CENTER)</td> <td>0.25</td> <td>0.30</td> <td>0.35</td> </tr> <tr> <td>WHITE</td> <td>0.26</td> <td>0.31</td> <td>0.36</td> </tr> </tbody> </table>	ITEM	MIN.	TYP.	MAX.	COLOR OF CIE COORDINATE (CENTER)	0.28	0.33	0.38	WHITE	0.30	0.35	0.40	ITEM	MIN.	TYP.	MAX.	COLOR OF CIE COORDINATE (CENTER)	0.25	0.30	0.35	WHITE	0.26	0.31	0.36							
	ITEM	MIN.	TYP.	MAX.																													
	COLOR OF CIE COORDINATE (CENTER)	0.28	0.33	0.38																													
	WHITE	0.30	0.35	0.40																													
ITEM	MIN.	TYP.	MAX.																														
COLOR OF CIE COORDINATE (CENTER)	0.25	0.30	0.35																														
WHITE	0.26	0.31	0.36																														
13	NOTE(7) : IF=200mA→ILED=20mA																																
15	8.1 TFT MODIFY SCK→SCL, SDI→SDA, SDO→SDA																																
17	10.1 LCD MODULE <table border="1"> <thead> <tr> <th>PIN NO.</th> <th>SYMBOL</th> <th>I/O</th> <th>FUNCTION</th> </tr> </thead> <tbody> <tr> <td>8</td> <td>SCK</td> <td>I</td> <td>SPI INTERFACE DATA CLOCK</td> </tr> <tr> <td>9</td> <td>SDI</td> <td>I</td> <td>SPI INTERFACE DATA</td> </tr> <tr> <td>10</td> <td>SDO</td> <td>O</td> <td>SPI INTERFACE DATA</td> </tr> </tbody> </table> <table border="1"> <thead> <tr> <th>PIN NO.</th> <th>SYMBOL</th> <th>I/O</th> <th>FUNCTION</th> </tr> </thead> <tbody> <tr> <td>8</td> <td>SCL</td> <td>I</td> <td>SPI INTERFACE DATA CLOCK</td> </tr> <tr> <td>9</td> <td>SDA</td> <td>I/O</td> <td>SPI INTERFACE DATA INPUT AND OUTPUT</td> </tr> <tr> <td>10</td> <td>SDA</td> <td>I/O</td> <td>SPI INTERFACE DATA INPUT AND OUTPUT</td> </tr> </tbody> </table>	PIN NO.	SYMBOL	I/O	FUNCTION	8	SCK	I	SPI INTERFACE DATA CLOCK	9	SDI	I	SPI INTERFACE DATA	10	SDO	O	SPI INTERFACE DATA	PIN NO.	SYMBOL	I/O	FUNCTION	8	SCL	I	SPI INTERFACE DATA CLOCK	9	SDA	I/O	SPI INTERFACE DATA INPUT AND OUTPUT	10	SDA	I/O	SPI INTERFACE DATA INPUT AND OUTPUT
PIN NO.	SYMBOL	I/O	FUNCTION																														
8	SCK	I	SPI INTERFACE DATA CLOCK																														
9	SDI	I	SPI INTERFACE DATA																														
10	SDO	O	SPI INTERFACE DATA																														
PIN NO.	SYMBOL	I/O	FUNCTION																														
8	SCL	I	SPI INTERFACE DATA CLOCK																														
9	SDA	I/O	SPI INTERFACE DATA INPUT AND OUTPUT																														
10	SDA	I/O	SPI INTERFACE DATA INPUT AND OUTPUT																														

CONFIDENTIAL
 Authorized for
 Emerging Display Technologies Corporation Only.
 Do not distribute without authorization.

TABLE OF CONTENTS

NO.	ITEM	PAGE
1.	GENERAL SPECIFICATIONS -----	1
2.	MECHANICAL SPECIFICATIONS -----	1, 2
3.	ABSOLUTE MAXIMUM RATINGS -----	3
4.	ELECTRICAL CHARACTERISTICS -----	4, 5
5.	TIMING CHARACTERISTICS -----	6 ~ 11
6.	OPTICAL CHARACTERISTICS -----	12, 13
7.	OUTLINE DIMENSIONS -----	14
8.	BLOCK DIMENSION -----	15
9.	DETAIL DRAWING OF DOT MATRIX -----	16
10.	INTERFACE SIGNALS -----	17, 18
11.	POWER SUPPLY -----	19
12.	CAPACITIVE TOUCH PANEL SPECIFICATION -----	20 ~ 23
13.	INSPECTION CRITERION -----	24 ~ 29
14.	RELIABILITY TEST -----	30
15.	CAUTION -----	31, 32

CONFIDENTIAL
Authorized for
Emerging Display Technologies Corporation Only.
Do not distribute without authorization.

1. GENERAL SPECIFICATIONS

1.1 DATA SHEET FOR CONTROLLER/DRIVER
PLEASE REFER TO :

SITRONIX ST7272A-G4

1.2 DATA SHEET FOR CAPACITIVE TOUCH PANEL CONTROLLER/DRIVER
PLEASE REFER TO :

HYCON HY4614

1.3 MATERIAL SAFETY DESCRIPTION

ASSEMBLIES SHALL COMPLY WITH EUROPEAN ROHS REQUIREMENTS, INCLUDING PROHIBITED MATERIALS/COMPONENTS CONTAINING LEAD, MERCURY, CADMIUM, HEXAVALENT CHROMIUM, POLYBROMINATED BIPHENYLS (PBB) AND POLYBROMINATED DIPHENYL ETHERS (PBDE), BIS(2-ETHYLHEXYL) PHTHALATE (DEHP), BUTYL BENZYL PHTHALATE (BBP), DIBUTYL PHTHALATE (DBP), DIISOBUTYL PHTHALATE (DIBP).

2. MECHANICAL SPECIFICATIONS

2.1 TFT MODULE MECHANICAL SPECIFICATIONS

(1) DISPLAY SIZE	-----	3.5 inch
(2) NUMBER OF DOTS	-----	320W * (RGB) * 240H DOTS
(3) MODULE SIZE	-----	76.8W * 63.8H * 4.86D mm (NOT INCLUDED FPC)
(4) VIEWING AREA	-----	71.6W * 54H mm
(5) ACTIVE AREA	-----	70.08W * 52.56H mm
(6) DOT SIZE	-----	0.073W * 0.219H mm
(7) PIXEL SIZE	-----	0.219W * 0.219H mm
(8) LCD TYPE	-----	TFT , TRANSMISSIVE, NORMALLY BLACK
(9) COLOR	-----	16.7M
(10) VIEWING DIRECTION	-----	SUPER WIDE VIEW
(11) BACK LIGHT	-----	LED , COLOR : WHITE
(12) INTERFACE MODE	-----	RGB 24BIT PARALLEL (DE/SYNC MODE)

MODEL NO.	VERSION	PAGE
ETM035013EDHA	3	2

2.2 CAPACITIVE TOUCH PANEL MECHANICAL SPECIFICATIONS

- (1) TOUCH PANEL SIZE ----- 3.5 inch
- (2) OUTER DIMENSION ----- 76.4W * 63H * 1.4D mm
(NOT INCLUDED FPC)
- (3) VIEWING AREA ----- 71.812W * 54.27H mm
- (4) ACTIVE AREA ----- 70.8W * 53.27H mm
- (5) INPUT TYPE ----- MULTI TOUCH
- (6) NUMBER OF TOUCH SENSOR ----- 14*10 SENSORS
- (7) RESOLUTION ----- 896*640
- (8) INTERFACE MODE ----- I2C

CONFIDENTIAL
Authorized for
Emerging Display Technologies Corporation Only.
Do not distribute without authorization.

3. ABSOLUTE MAXIMUM RATINGS

3.1 ELECTRICAL ABSOLUTE MAXIMUM RATINGS

ITEM	SYMBOL	MIN.	MAX.	UNIT	REMARK
POWER SUPPLY VOLTAGE	VDD-VSS	-0.3	4	V	—
STATIC ELECTRICITY	—	—	—	V	NOTE (1)
POWER DISSIPATION FOR LED BACKLIGHT	PD	—	465	mW	—
FORWARD CURRENT FOR LED BACKLIGHT	ILED	—	30	mA	—
REVERSE VOLTAGE FOR LED BACKLIGHT	VR	—	30	V	—

NOTE (1) : LCM SHOULD BE GROUND DURING LCM HANDLING.

3.2 CAPACITIVE TOUCH PANEL ELECTRICAL ABSOLUTE MAXIMUM RATINGS

ITEM	SYMBOL	MIN.	MAX.	UNIT	REMARK
POWER SUPPLY VOLTAGE	VDD1-VSS1	-0.2	4.0	V	—
INPUT VOLTAGE	VIN	-0.2	4.0	V	—

3.3 ENVIRONMENTAL ABSOLUTE MAXIMUM RATINGS

ITEM	OPERATING		STORAGE		REMARK
	MIN.	MAX.	MIN.	MAX.	
AMBIENT TEMPERATURE	-20°C	70°C	-30°C	80°C	NOTE (1) , (2)
HUMIDITY	NOTE (3)		NOTE (3)		WITHOUT CONDENSATION
VIBRATION	—	2.45m/s ² (0.25G)	—	11.76m/s ² (1.2G)	10~100 Hz XYZ DIRECTIONS 1 HR EACH
SHOCK	—	29.4m/s ² (3G)	—	490.0m/s ² (50G)	10 ms XYZ DIRECTIONS 1 TIME EACH
CORROSIVE GAS	NOT ACCEPTABLE		NOT ACCEPTABLE		

NOTE (1) : Ta AT -30°C : WILL BE 48HRS MAX .

80°C : WILL BE 168HRS MAX .

NOTE (2) : BACKGROUND COLOR CHANGES SLIGHTLY DEPENDING ON AMBIENT TEMPERATURE THIS PHENOMENON IS REVERSIBLE .

NOTE (3) : Ta ≤ 60°C : 90%RH MAX (96HRS MAX).

Ta > 60°C : ABSOLUTE HUMIDITY MUST BE LOWER THAN THE HUMIDITY OF 90%RH AT 60°C(96HRS MAX).

4. ELECTRICAL CHARACTERISTICS

4.1 TFT MODULE ELECTRICAL CHARACTERISTICS

Ta = 25 °C

ITEM	SYMBOL	CONDITION	MIN.	TYP.	MAX.	UNIT	REMARK
POWER SUPPLY VOLTAGE	VDD-VSS	—	3.0	3.3	3.6	V	
LOGIC HIGH INPUT VOLTAGE	V _{IH}	—	0.7VDD	—	—	V	NOTE (1)
LOGIC LOW INPUT VOLTAGE	V _{IL}	—	—	—	0.3VDD	V	NOTE (1)
LOGIC HIGH OUTPUT VOLTAGE	V _{OH}	I _{OH} =-1.0mA	VDD-0.4	—	VDD	V	
LOGIC LOW OUTPUT VOLTAGE	V _{OL}	I _{OL} =+1.0mA	VSS	—	VSS+0.4	V	
POWER SUPPLY CURRENT	IDD	VDD-VSS =3.3V	—	20	30	mA	NOTE (2)
POWER SUPPLY VOLTAGE FOR LED BACKLIGHT	VLED-VLSS	I _{LED} =20mA	—	18.0	18.6	V	NOTE (1)
LED LIFE TIME	—	I _F =20mA (PER LED)	30K	40K	—	HRS	NOTE (5) NOTE (6)

NOTE (1) : APPLIED TO TERMINALS /RESET, B7~B0, G7~G0, R7~R0, DCLK, HSYNC, VSYNC, ENB, SHUT.

NOTE (2) : THE DISPLAY PATTERN IS ALL "WHITE".

NOTE (3) : INTERNAL CIRCUIT DIAGRAM OF BACKLIGHT

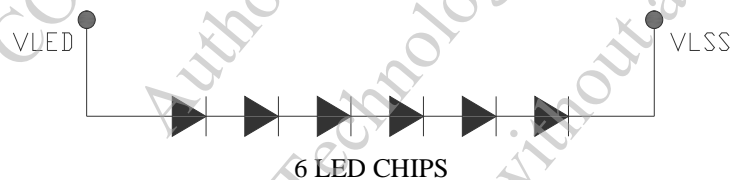

6 LED CHIPS

NOTE (4) : AMBIENT TEMP .VS. ALLOWABLE FORWARD CURRENT.(PER LED)

Forward current derating curve VS.Ambient temperature

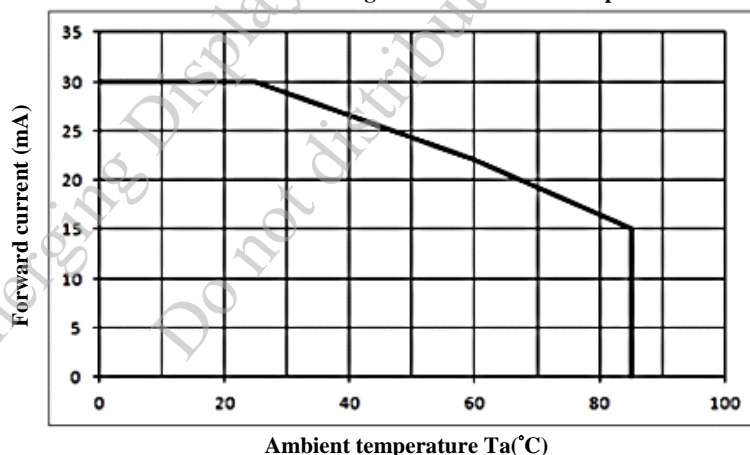

NOTE (5) : CONDITIONS; Ta=25 °C, CONTINUOUS LIGHTING.

NOTE (6) : DEFINITIONS OF LIFE TIME :

LCM LUMINANCE BECOMES HALF OF THE INITIAL VALUE.

4.2 CAPACITIVE TOUCH PANEL ELECTRICAL CHARACTERISTICS

Ta=25°C

ITEM	SYMBOL	CONDITION	MIN.	TYP.	MAX.	UNIT
POWER SUPPLY VOLTAGE	VDD1-VSS1	—	2.8	3.3	3.6	V
LOGIC HIGH INPUT VOLTAGE	VIH	—	—	0.7*VDD1	—	V
LOGIC LOW INPUT VOLTAGE	VIL	—	—	0.3*VDD1	—	V
LOGIC HIGH OUTPUT VOLTAGE	VOH	IOH=10mA	VDD1-0.3	—	—	V
LOGIC LOW OUTPUT VOLTAGE	VOL	IOH=-10mA	—	—	VSS1+0.3	V
POWER SUPPLY CURRENT	IDD1	VDD1-VSS1 =3.30V	—	15	23	mA

CONFIDENTIAL
Authorized for
Emerging Display Technologies Corporation Only.
Do not distribute without authorization.

5. TIMING CHARACTERISTICS

5.1 FOR LCD MODULE

5.1.1 PIXEL TIMING

ITEM	SYMBOL	MIN.	TYP.	MAX.	UNIT
CLK PULSE DUTY	Tclk	40	50	60	%
HSYNC WIDTH	Thw	2	—	—	DCLK
HSYNC PERIOD	Th	55	60	65	us
VSYNC SETUP TIME	Tvst	12	—	—	ns
VSYNC HOLD TIME	Tvhd	12	—	—	ns
HSYNC SETUP TIME	Thst	12	—	—	ns
HSYNC HOLD TIME	Thhd	12	—	—	ns
DATA SETUP TIME	Tdsu	12	—	—	ns
DATA HOLD TIME	Tdhd	12	—	—	ns
DE SETUP TIME	Tdest	12	—	—	ns
DE HOLD TIME	Tdehd	12	—	—	ns

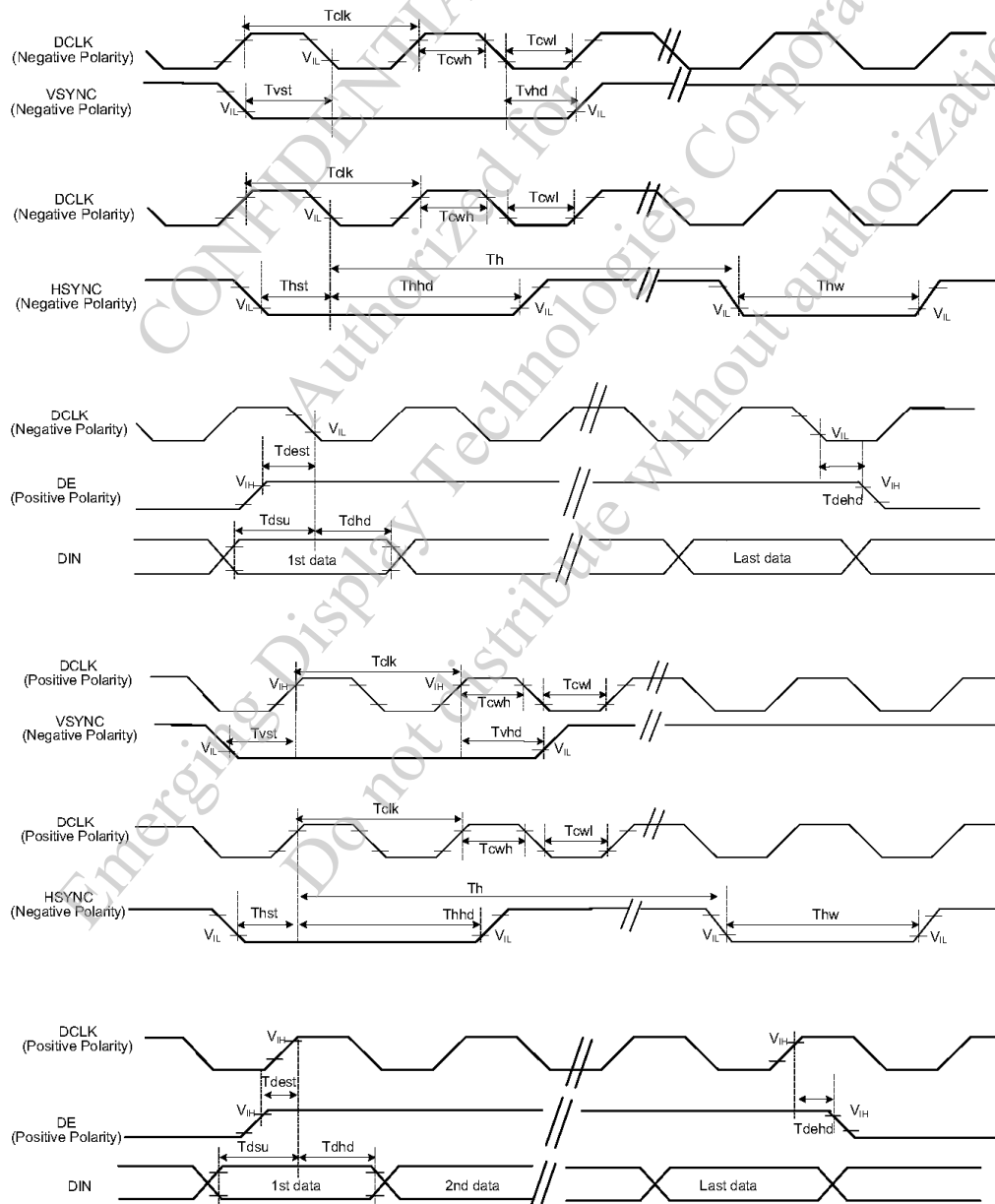

5.1.2 PARALLEL 24-BIT RGB INPUT TIMING TABLE

ITEM	SYMBOL	MIN.	TYP.	MAX.	UNIT	NOTE	
DCLK FREQUENCY	Fclk	5	6	8	MHz		
DCLK PERIOD	Tclk	125	167	200	ns		
HSYNC	PERIOD TIME	Th	325	371	438	DCLK	
	DISPLAY PERIOD	Thdisp	—	320	—	DCLK	
	BACK PORCH	Thbp	3	43	43	DCLK	SYNC MODE BACK PORCH CONTROL BY H_BLANKING[7:0] SETTING Thbp=H_BLANKING[7:0]
	FRONT PORCH	Thfp	2	8	75	DCLK	
	PULSE WIDTH	Thw	2	4	43	DCLK	
VSYNC	PERIOD TIME	Tv	244	260	289	HSYNC	
	DISPLAY PERIOD	Tvdisp	—	240	—	HSYNC	
	BACK PORCH	Tvbp	2	12	12	HSYNC	SYNC MODE BACK PORCH CONTROL BY V_BLANKING[7:0] SETTING Tvbp=V_BLANKING[7:0]
	FRONT PORCH	Tvfp	2	8	37	HSYNC	
	PULSE WIDTH	Tvw	2	4	12	HSYNC	

NOTE: IT IS NECESSARY TO KEEP Tvbp =12 AND Thbp =43 IN SYNC MODE. DE MODE IS UNNECESSARY TO KEEP IT.

5.1.3 PARALLEL RGB INTERFACE (SYNC MODE)

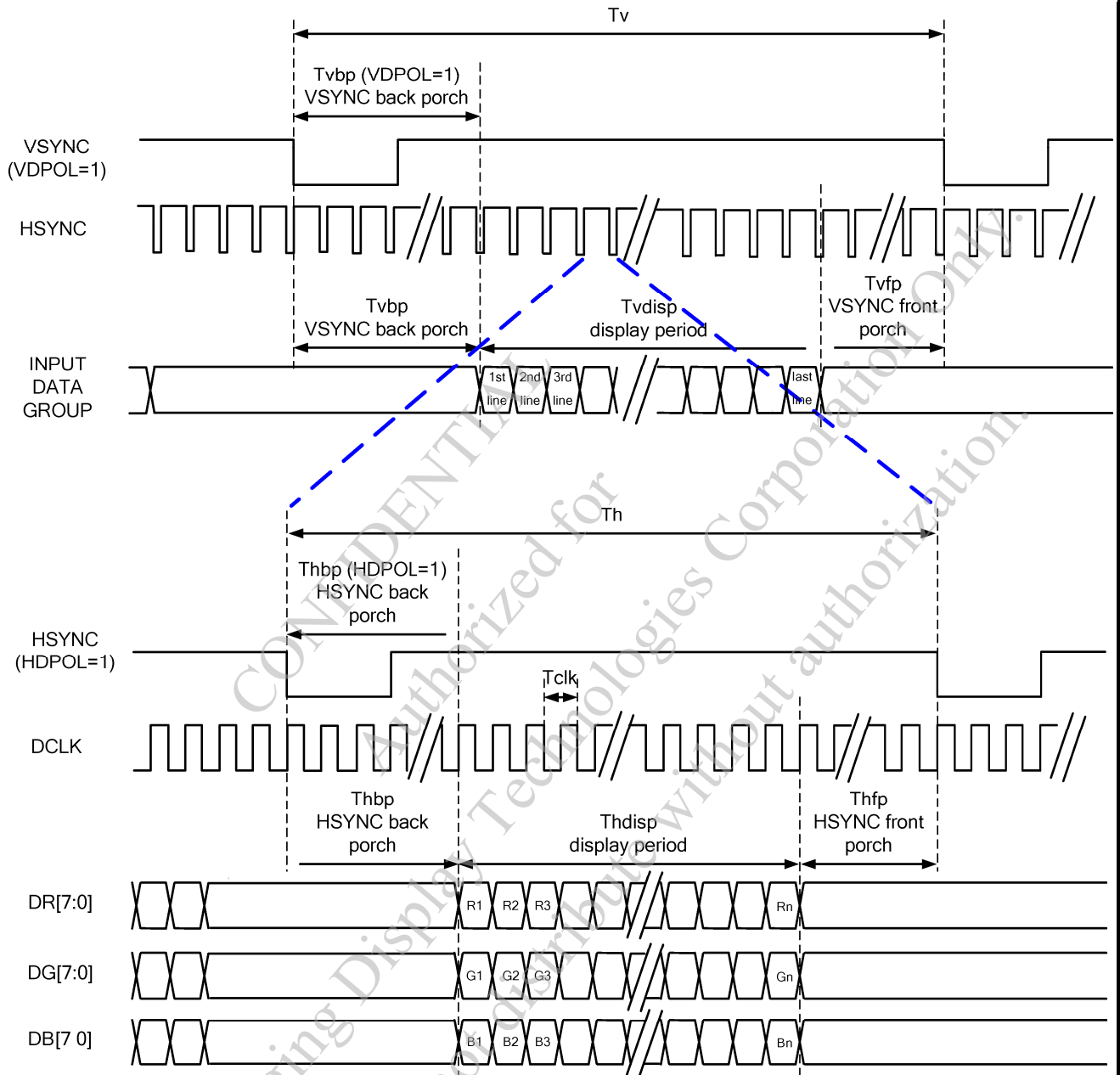

5.1.4 PARALLEL RGB INTERFACE (DE MODE)

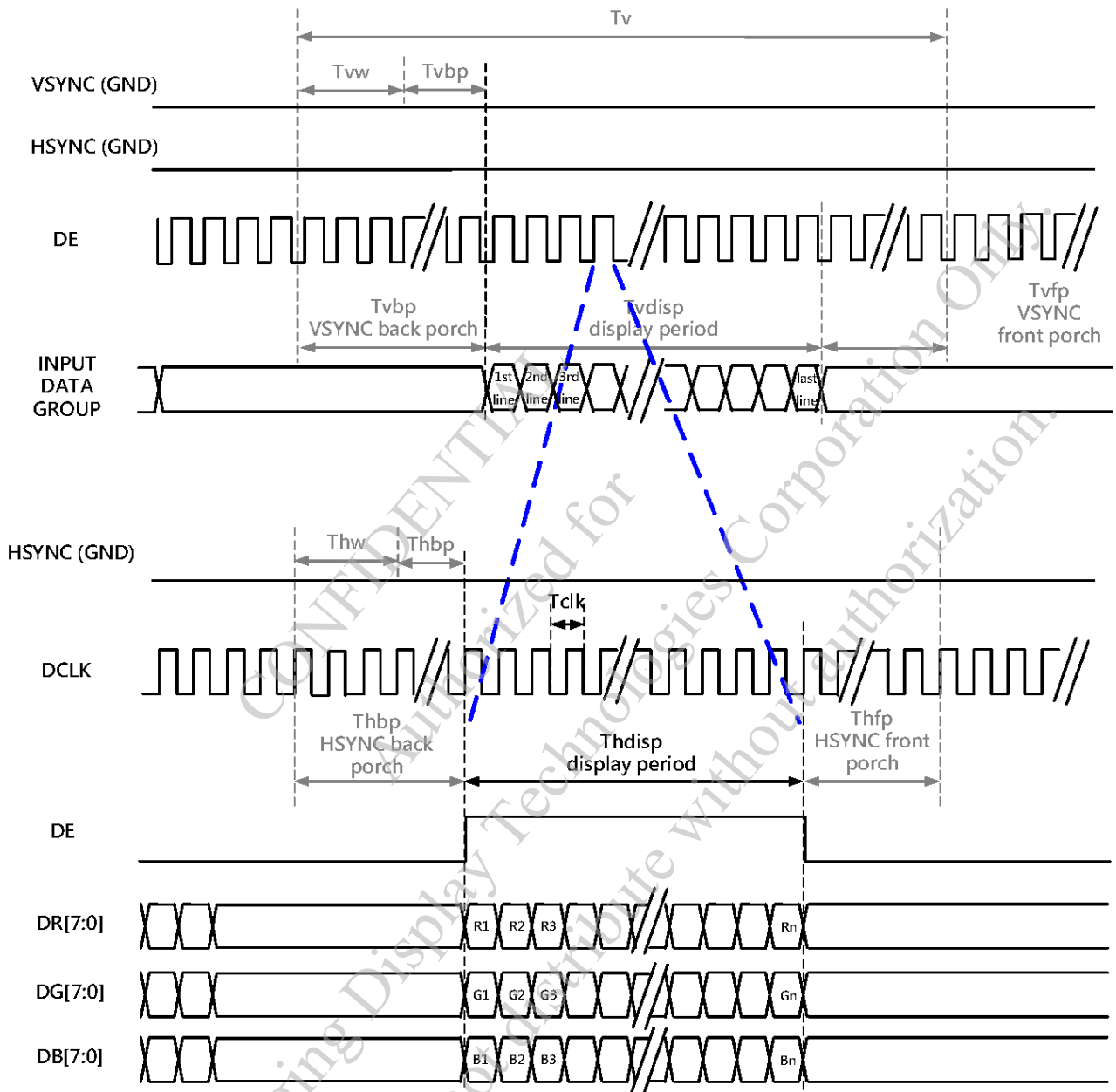

5.2 FOR CTP MODULE

5.2.1 I2C INTERFACE TIMING CHARACTERISTICS

ITEM	MIN.	TYP.	MAX.	UNIT
SCL FREQUENCY	—	—	400	KHz
BUS FREE TIME BETWEEN A STOP AND START CONDITION	1.3	—	—	us
HOLD TIME (REPEATED) START CONDITION	0.6	—	—	us
DATA SETUP TIME	100	—	—	ns
SETUP TIME FOR A REPEATED START CONDITION	0.6	—	—	us
SETUP TIME FOR STOP CONDITION	0.6	—	—	us

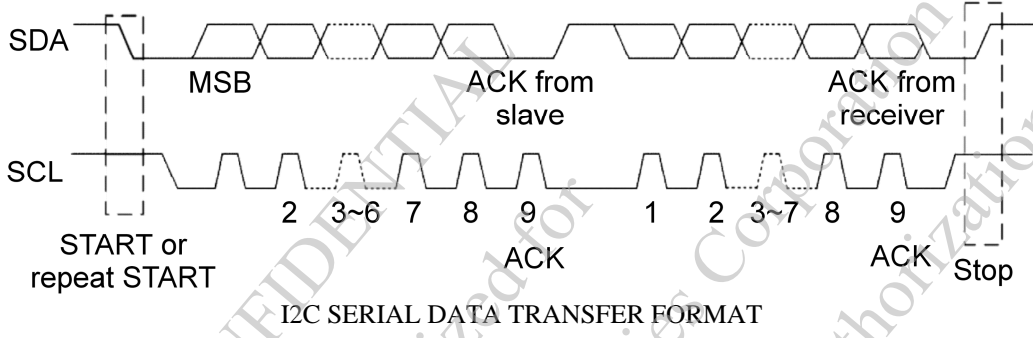

CONFIDENTIAL
 Authorized for
 Emerging Display Technologies Corporation Only.
 Do not distribute without authorization.

5.2.2 POWER SEQUENCE

ITEM	SYMBOL	MIN.	TYP.	MAX.	UNIT
RISE TIME FROM 0.1VDD TO 0.9VDD	Tris	—	—	5	ms
TIME OF RESETTING TO BE LOW BEFORE POWERING ON	Trtp	100	—	—	us
TIME OF STARTING TO REPORT POINT AFTER POWERING ON	Tpon	200	—	—	ms
RESET TIME AFTER VDD POWERING ON	Tvdr	1	—	—	ms
TIME OF STARTING TO REPORT POINT AFTER RESETTING	Trsi	200	—	—	ms
RESET TIME	Trst	2	—	—	ms

POWER RISE TIMING

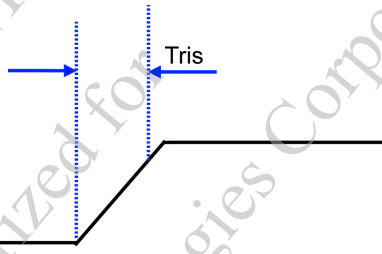

POWER ON / OFF TIMING

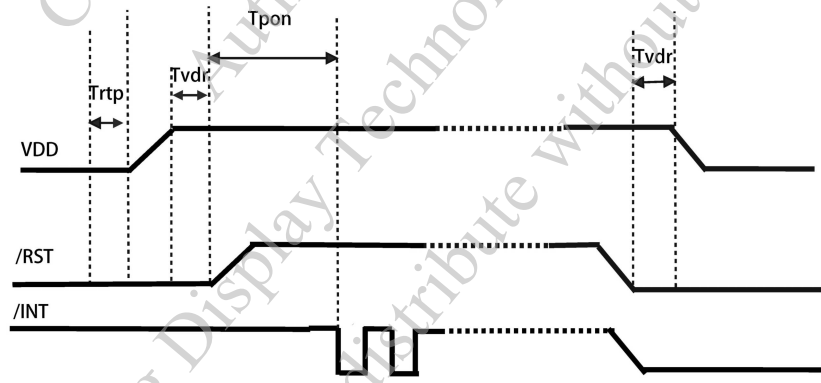

RESET SEQUENCE

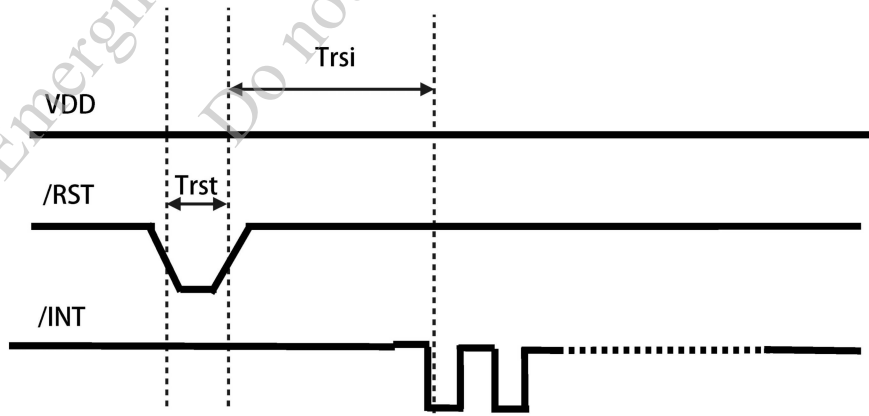

6. OPTICAL CHARACTERISTICS (NOTE 1)

6.1 OPTICAL CHARACTERISTICS

Ta=25±2°C

ITEM	SYMBOL	CONDITION	MIN.	TYP.	MAX.	UNIT	REMARK	
VIEWING ANGLE	θ_{y+}	CR≥10	$\theta_x=0^\circ$	70	80	—	deg	NOTE (2)
	θ_{y-}			70	80	—	deg	
	θ_{x+}		$\theta_y=0^\circ$	70	80	—	deg	NOTE (3)
	θ_{x-}			70	80	—	deg	
CONTRAST RATIO (CENTER)	CR	$\theta_x=0^\circ, \theta_y=0^\circ$	600	800	—	—	NOTE (3)	
RESPONSE TIME	T _R (rise)		—	10	20	msec	NOTE (4)	
	T _F (fall)		—	15	30	msec	NOTE (4)	
COLOR OF CIE COORDINATE (CENTER)	WHITE	W _x	$\theta_x=0^\circ, \theta_y=0^\circ$ VDD=3.3V VDD1=3.3V ILED=20mA	0.25	0.30	0.35	—	NOTE (5)
		W _y		0.26	0.31	0.36		
	RED	R _x		0.57	0.62	0.67		
		R _y		0.30	0.35	0.40		
	GREEN	G _x		0.32	0.37	0.42		
		G _y		0.54	0.59	0.64		
	BLUE	B _x		0.09	0.14	0.19		
		B _y		0.03	0.08	0.13		
THE BRIGHTNESS OF MODULE(CENTER)	B		380	420	—	cd/m ²	NOTE (6)	
THE UNIFORMITY OF MODULE	—		70	—	—	%	NOTE (7)	

NOTE (1) : TEST EQUIPMENT SETUP :

AFTER STABILIZING AND LEAVING THE PANEL ALONE AT A GIVEN TEMPERATURE FOR 30 MINUTES, MEASUREMENT SHOULD BE EXECUTED IN A STABLE, WINDLESS, AND DARK ROOM.

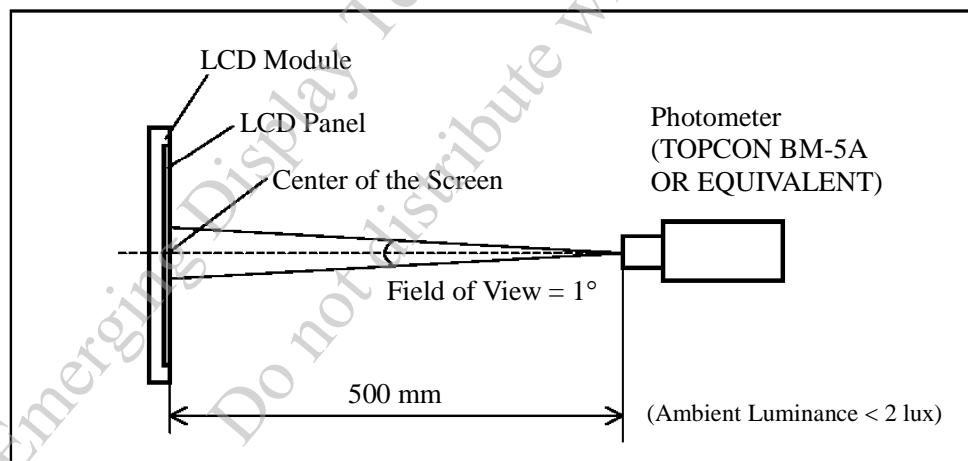

NOTE (2) : DEFINITION OF VIEWING ANGLE :

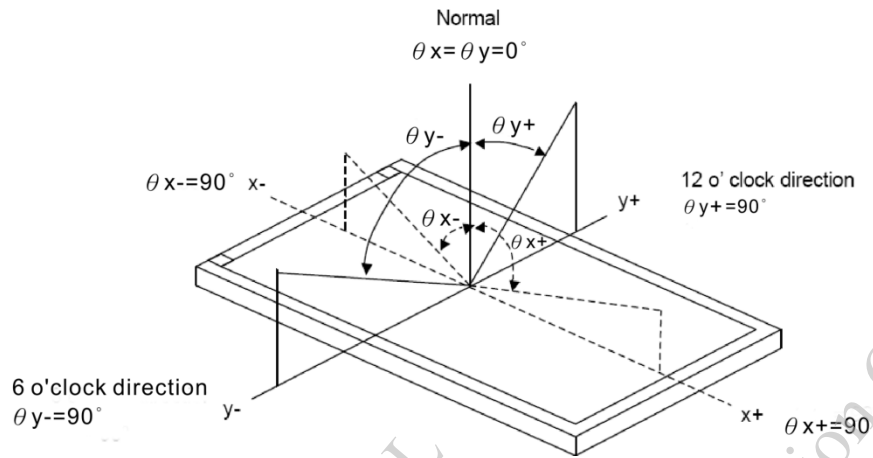

NOTE (3) : DEFINITION OF CONTRAST RATIO (CR) :

MEASURED AT THE CENTER POINT OF MODULE

$$\text{CONTRAST RATIO (CR)} = \frac{\text{BRIGHTNESS MEASURED WHEN LCD IS AT "WHITE STATE"}}{\text{BRIGHTNESS MEASURED WHEN LCD IS AT "BLACK STATE"}}$$

NOTE (4) : DEFINITION OF RESPONSE TIME : T_R AND T_F

THE FIGURE BELOW IS THE OUTPUT SIGNAL OF THE PHOTO DETECTOR.

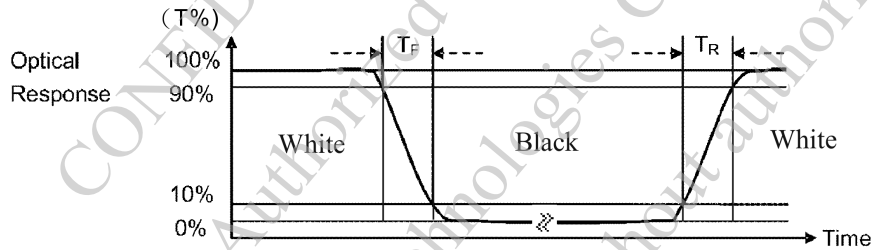

NOTE (5) : DEFINITION OF COLOR CHROMATICITY

- (a) THE 100% TRANSMISSION IS DEFINED AS THE TRANSMISSION OF LCD PANEL WHEN ALL THE INPUT TERMINALS OF MODULE ARE ELECTRICALLY POWERED ON.
- (b) MEASURED AT THE CENTER POINT OF MODULE

NOTE (6) : MEASURED THE BRIGHTNESS OF WHITE STATE AT CENTER POINT.

NOTE (7) : (a) DEFINITION OF BRIGHTNESS UNIFORMITY

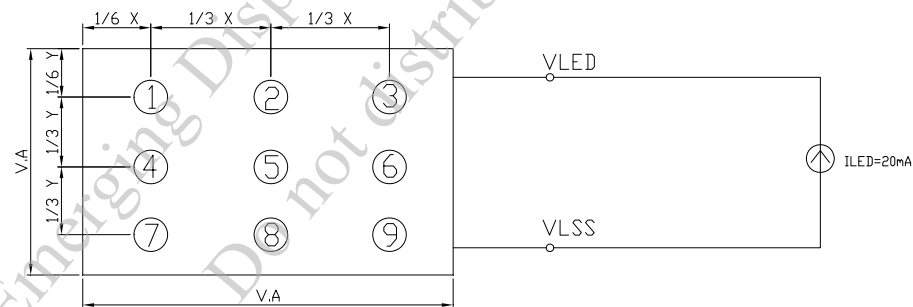

UNIT : mm

(b) THE BRIGHTNESS UNIFORMITY CALCULATING METHOD

$$\text{UNIFORMITY} : \frac{\text{MINIMUM BRIGHTNESS}}{\text{MAXIMUM BRIGHTNESS}} * 100\%$$

7. OUTLINE DIMENSIONS

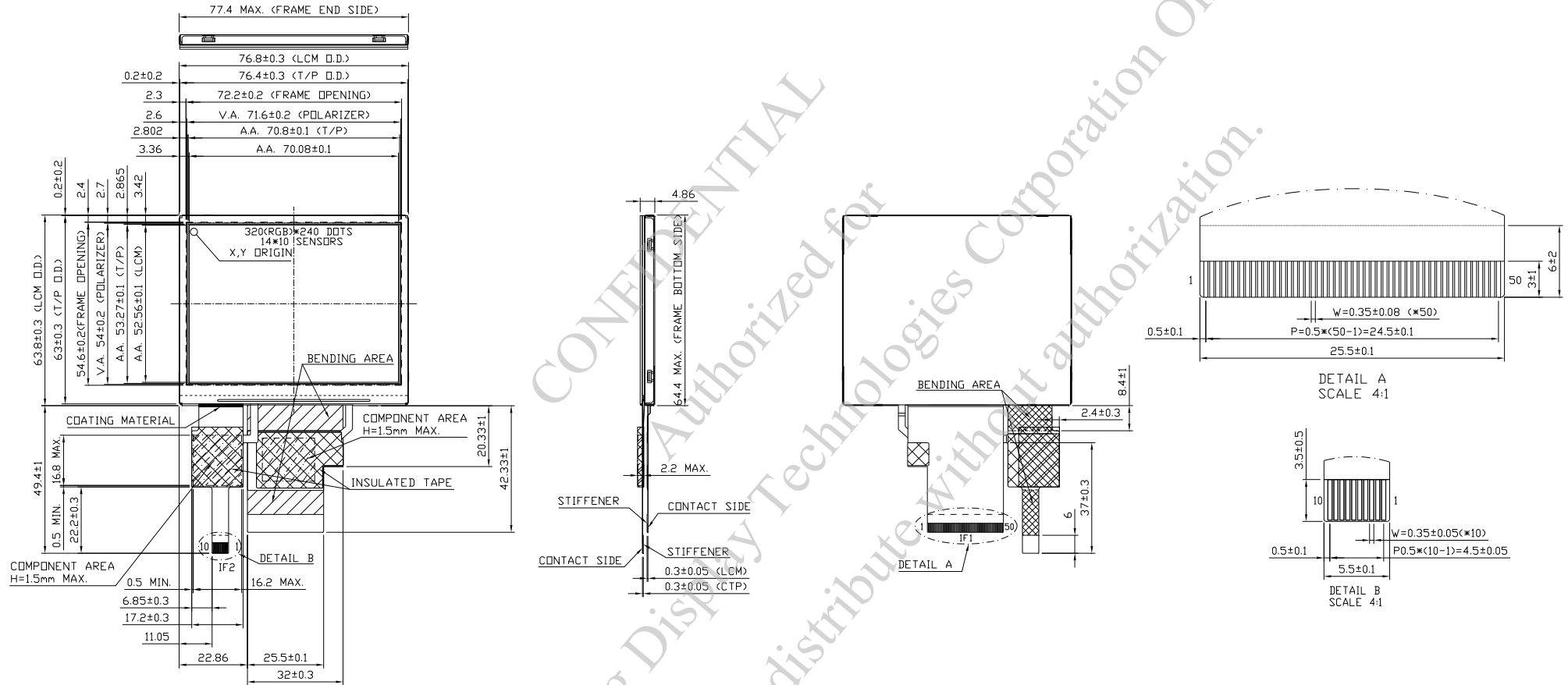

UNIT : mm

SCALE : NTS

NOT SPECIFIED LENGTH TOLERANCE IS ± 0.5

NOTE :

IF1 RECOMMEND MATCH CONNECTOR KYOCERA : 04 6299 050 SERIES

IF2 RECOMMEND MATCH CONNECTOR KYOCERA : 04 6240 010 SERIES

8. BLOCK DIMENSION

8.1 TFT

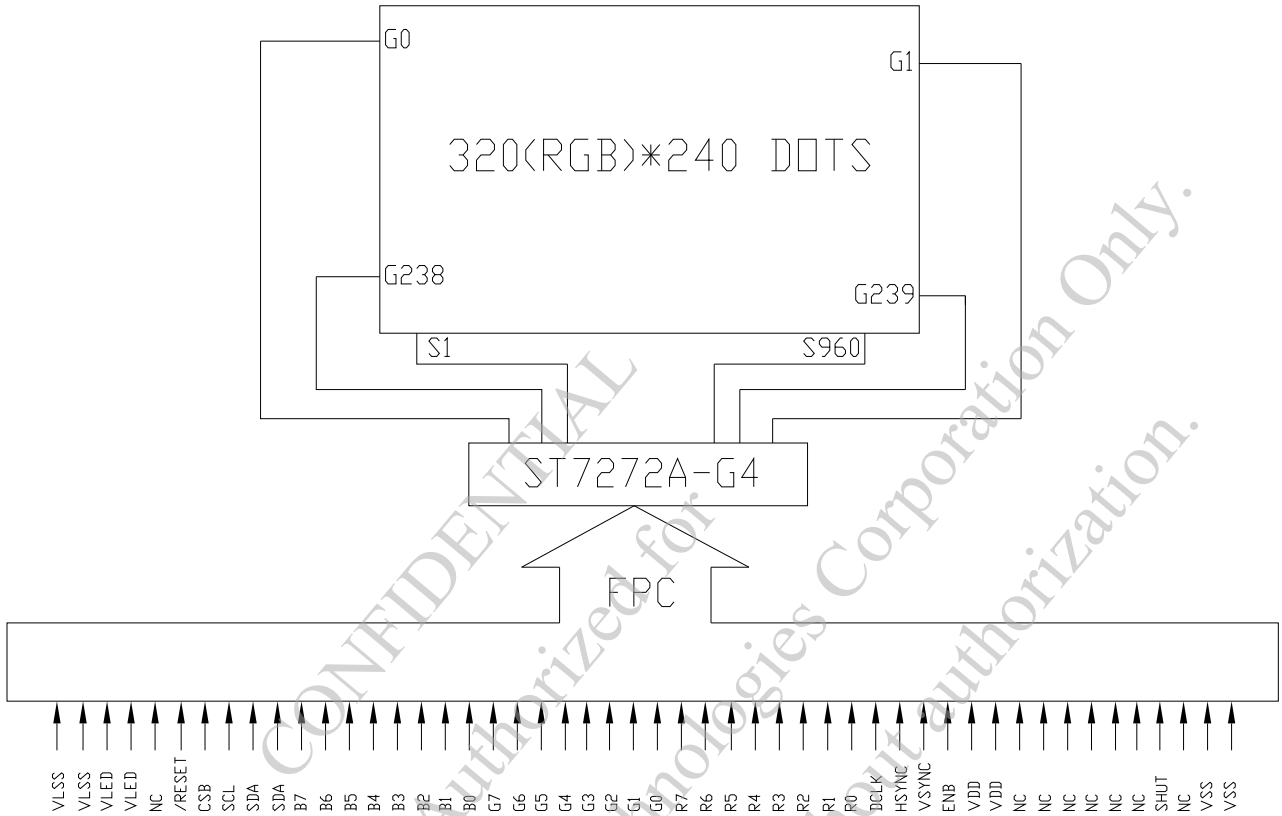

8.2 CTP

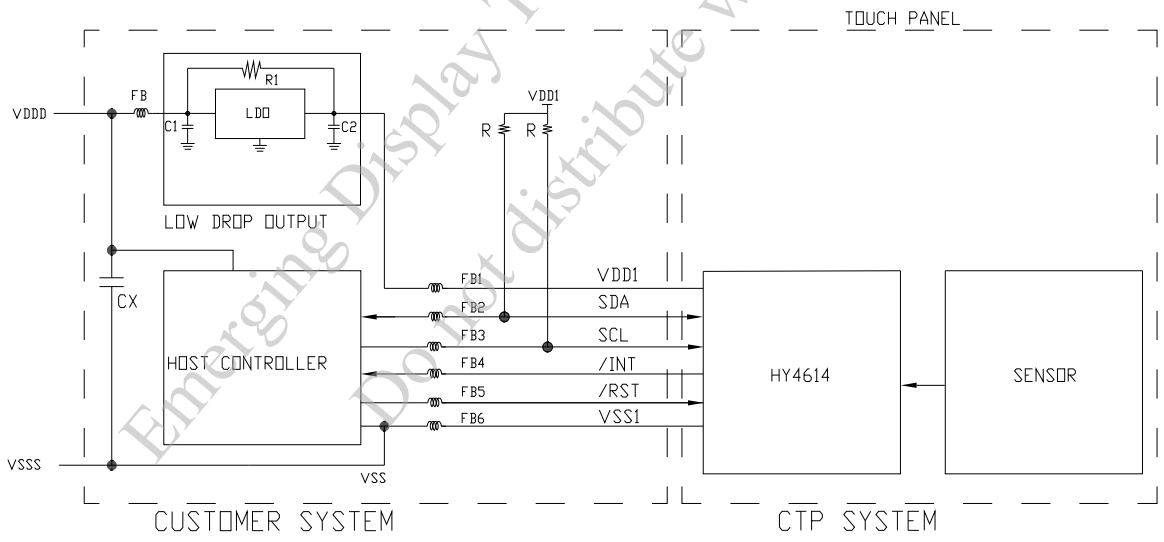

- NOTE (1) : THE STANDARD IIC COMMUNICATION INTERFACE, SUPREME SCL CLOCK IS 400 KHZ, SLAVE ADDRESS CAN BE SET UP, SUPPORTS VDD LEVEL POWER, NEEDS PULL HIGH RESISTANCE AND WE RECOMMEND THE PULL HIGH RESISTANCE IS 2.0K OHM.
- NOTE (2) : POWER SUPPLY SHALL BE CLEAN AND NOISE FREE. ADDITIONAL FILTERING OR A SEPARATE LDO (LOW DROP OUT) REGULATOR CAN BE REQUIRED. C1 AND C2 CAPACITORS RECOMMENDATION : 4.7μF OR 10 μF

9. DETAIL DRAWING OF DOT MATRIX

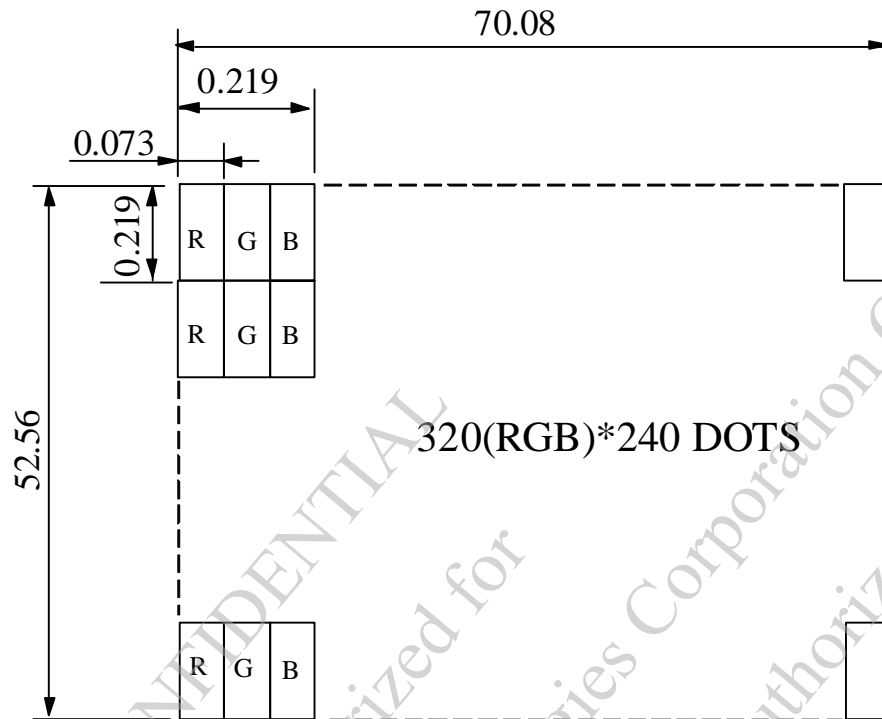

UNIT : mm
SCALE : NTS
NOT SPECIFIED TOLERANCE IS ± 0.1
DOTS MATRIX TOLERANCE IS ± 0.01

CONFIDENTIAL
Authorized for Emerging Display Technologies Corporation Only.
Do not distribute without authorization.

10. INTERFACE SIGNALS

10.1 LCD MODULE

PIN NO.	SYMBOL	I/O/P	FUNCTION
1	VLSS	P	POWER SUPPLY FOR LED BACKLIGHT (CATHODE)
2	VLSS	P	POWER SUPPLY FOR LED BACKLIGHT (CATHODE)
3	VLED	P	POWER SUPPLY FOR LED BACKLIGHT (ANODE)
4	VLED	P	POWER SUPPLY FOR LED BACKLIGHT (ANODE)
5	NC	—	NON CONNECTION
6	/RESET	I	HARDWARE RESET
7	CSB	I	SPI INTERFACE CHIP SELECT BAR
8	SCL	I	SPI INTERFACE DATA CLOCK
9	SDA	I/O	SPI INTERFACE DATA INPUT AND OUTPUT
10	SDA	I/O	SPI INTERFACE DATA INPUT AND OUTPUT
11	B7	I	BLUE DATA BIT 7
12	B6	I	BLUE DATA BIT 6
13	B5	I	BLUE DATA BIT 5
14	B4	I	BLUE DATA BIT 4
15	B3	I	BLUE DATA BIT 3
16	B2	I	BLUE DATA BIT 2
17	B1	I	BLUE DATA BIT 1
18	B0	I	BLUE DATA BIT 0
19	G7	I	GREEN DATA BIT 7
20	G6	I	GREEN DATA BIT 6
21	G5	I	GREEN DATA BIT 5
22	G4	I	GREEN DATA BIT 4
23	G3	I	GREEN DATA BIT 3
24	G2	I	GREEN DATA BIT 2
25	G1	I	GREEN DATA BIT 1
26	G0	I	GREEN DATA BIT 0
27	R7	I	RED DATA BIT 7
28	R6	I	RED DATA BIT 6
29	R5	I	RED DATA BIT 5
30	R4	I	RED DATA BIT 4
31	R3	I	RED DATA BIT 3
32	R2	I	RED DATA BIT 2
33	R1	I	RED DATA BIT 1
34	R0	I	RED DATA BIT 0
35	DCLK	I	DOT DATA CLOCK

PIN NO.	SYMBOL	I/O/P	FUNCTION	
36	HSYNC	I	HORIZONTAL SYNC INPUT	DE MODE : HSYNC, VSYNC FLOATING SYNC MODE : ENB FLOATING
37	VSYNC	I	VERTICAL SYNC INPUT	
38	ENB	I	DATA ENABLE INPUT	
39	VDD	P	ANALOG POWER SUPPLY	
40	VDD	P	ANALOG POWER SUPPLY	
41	NC	—	NON CONNECTION	
42	NC	—	NON CONNECTION	
43	NC	—	NON CONNECTION	
44	NC	—	NON CONNECTION	
45	NC	—	NON CONNECTION	
46	NC	—	NON CONNECTION	
47	SHUT	I	DISPLAY SHUT DOWN PIN TO PUT THE DRIVER INTO SLEEP MODE. CONNECT TO VCC FOR SLEEP MODE. CONNECT TO VSS FOR NORMAL OPERATING MODE.	
48	NC	—	NON CONNECTION	
49	VSS	P	GROUND	
50	VSS	P	GROUND	

10.2 CTP MODULE

PIN NO.	SYMBOL	FUNCTION
1	VSS1	GROUND
2	VDD1	POWER SUPPLY VOLTAGE
3	SCL	I2C CLOCK INPUT
4	NC	NON CONNECTION
5	SDA	I2C DATA INPUT AND OUTPUT
6	NC	NON CONNECTION
7	/RST	EXTERNAL RESET, LOW IS ACTIVE
8	NC	NON CONNECTION
9	/INT	EXTERNAL INTERRUPT TO THE HOST
10	VSS1	GROUND

11. POWER SUPPLY

11.1 POWER SUPPLY FOR LCM

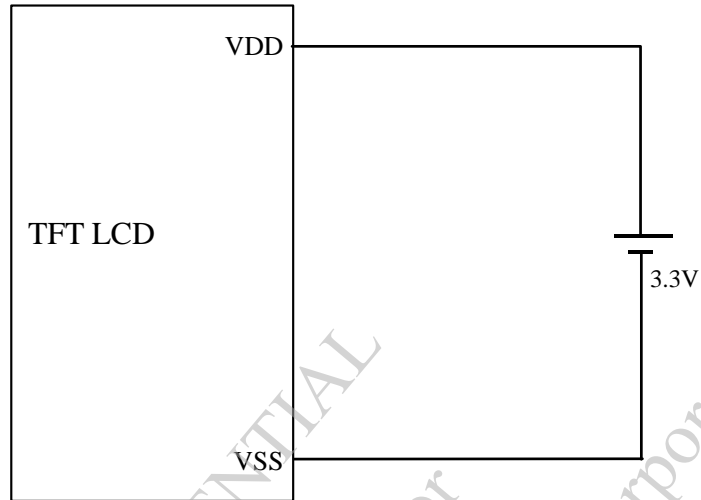

11.2 POWER SUPPLY FOR LED BACKLIGHT

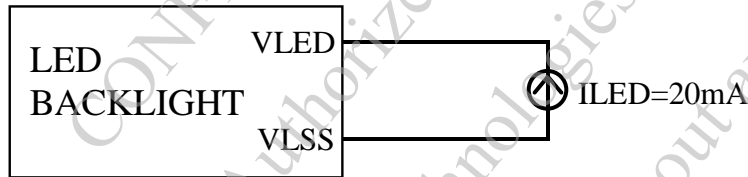

11.3 POWER SUPPLY FOR TOUCH PANEL

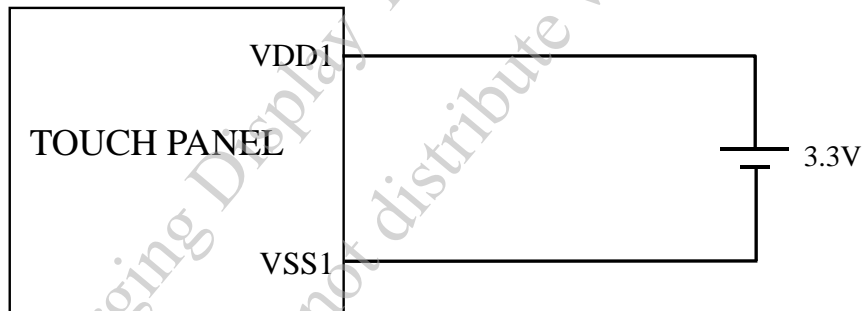

12. CAPACITIVE TOUCH PANEL SPECIFICATION

12.1 OPTICAL CHARACTERISTICS

ITEM	CONDITION	MIN.	TYP.	MAX.	UNIT
TRANSPARENCY NOTE (1)	Ta = 25°C λ = 550nm	85	—	—	%

NOTE (1) : OPTICAL MEASUREMENT SHOULD BE EXECUTED AFTER PANEL IS SECURED.
MEASUREMENT PROCESS SHOULD BE EXECUTED IN A STABLE, WINDLESS, AND DARK ROOM.
OPTICAL SPECIFICATIONS SHOULD BE MEASURED BY SPECTROPHOTOMETER.

12.2 HARDNESS

ITEM	DESCRIPTION
SURFACE HARDNESS	7H (MIN.)

12.3 DURABILITY

USING STEEL BALL AND FALLING ON TOUCH PANEL SURFACE, FROM THE HEIGHT MUST PASS BELOW CONDITIONS :

ITEM	CONDITION	INSPECTION METHOD	DESCRIPTION
STEEL BALL DROP TEST	WEIGHT : 67g HEIGHT OF FALL : 30 cm	VISUAL INSPECTION	SIGN OF FRACTURE OR DAMAGE IS NOT ACCEPTABLE 3 TIMES/ 1 POINTS, 25°C(CENTER TEST)

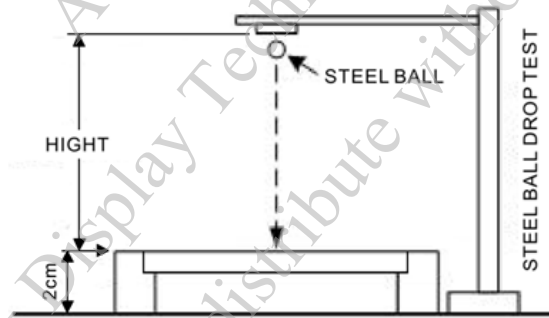

12.4 PROTOCOL

12.4.1 I2C READ

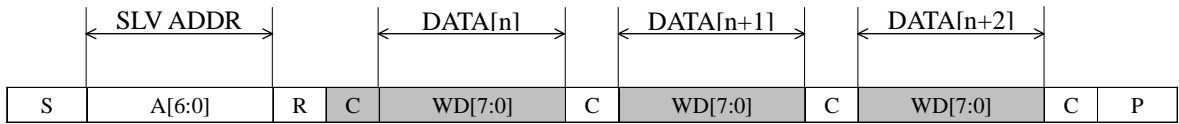

CHARACTER	DESCRIPTION
S	I2C START OR I2C RESTART
A[6:0]	SLAVE ADDRESS, THE VALUE CAN BE CUSTOMIZED
R	OPERATOR BYTE, SHOULD BE 1'b1, STANDS FOR READ
C	ACK SIGNAL
P	STOP SIGNAL (STOP SIGNAL IS OPTIONAL, RESTART SIGNAL IS ALSO OK FOR NEXT PACKET)

SLAVE ADDRESS=0x38

12.4.2 INTERRUPT SIGNAL FOR CTPM TO HOST
AS FOR STANDARD CTPM, HOST NEED TO USE BOTH INTERRUPT CONTROL SIGNAL AND SERIAL DATA INTERFACE TO GET THE TOUCH DATA.
HERE IS THE TIMING TO GET TOUCH DATA

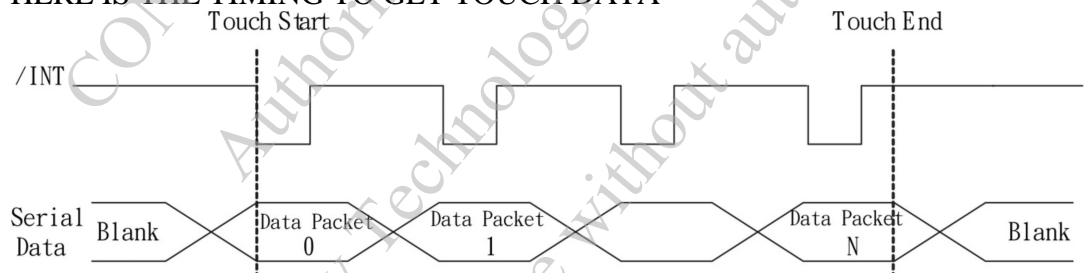

12.4.3 READ TOUCH DATA PACKET

WE DEFINED A CTPM PERIOD AS EACH CAPACITANCE DATA GATHERING AND DATA PROCESS, IN EACH CTPM, IF THERE IS A TOUCH DETECTS, THERE WILL WE A FAME OF TOUCH DATA. HOST CAN GET THE SPECIFIED FORMAT TOUCH DATA BY SERIAL DATA INTERFACE.

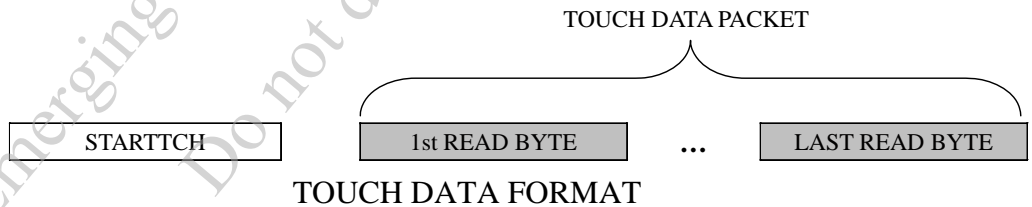

TOUCH DATA READ PROTOCOL

IN THIS MODE THE CTP IS FULLY FUNCTIONAL AS A TOUCH SCREEN CONTROLLER. READ AND WRITE ACCESS ADDRESS IS JUST LOGICAL ADDRESS WHICH IS NOT ENFORCED BY HARDWARE OR FIRMWARE. HERE IS THE OPERATING MODE REGISTER MAP.

ADDRESS	NAME	BIT7	BIT6	BIT5	BIT4	BIT3	BIT2	BIT1	BIT0	HOST ACCESS	
02h	TD_STATUS					NUMBER OF TOUCH POINTS[3:0]				R	
03h	TOUCH1_XH	1 st EVENT FLAG				1 st TOUCH X POSITION[11:8]				R	
04h	TOUCH1_XL	1 st TOUCH X POSITION[7:0]								R	
05h	TOUCH1_YH	1 st TOUCH ID[3:0]					1 st TOUCH Y POSITION[11:8]				R
06h	TOUCH1_YL	1 st TOUCH Y POSITION[7:0]								R	
07h											
08h											
09h	TOUCH2_XH	2 nd EVENT FLAG				2 nd TOUCH X POSITION[11:8]				R	
0Ah	TOUCH2_XL	2 nd TOUCH X POSITION[7:0]								R	
0Bh	TOUCH2_YH	2 nd TOUCH ID[3:0]					2 nd TOUCH Y POSITION[11:8]				R
0Ch	TOUCH2_YL	2 nd TOUCH Y POSITION[7:0]								R	
0Dh										R	
0Eh										R	
0Fh	TOUCH3_XH	3 rd EVENT FLAG				3 rd TOUCH X POSITION[11:8]				R	
10h	TOUCH3_XL	3 rd TOUCH X POSITION[7:0]								R	
11h	TOUCH3_YH	3 rd TOUCH ID[3:0]					3 rd TOUCH Y POSITION[11:8]				R
12h	TOUCH3_YL	3 rd TOUCH Y POSITION[7:0]								R	
13h										R	
14h										R	
15h	TOUCH4_XH	4 th EVENT FLAG				4 th TOUCH X POSITION[11:8]				R	
16h	TOUCH4_XL	4 th TOUCH X POSITION[7:0]								R	
17h	TOUCH4_YH	4 th TOUCH ID[3:0]					4 th TOUCH Y POSITION[11:8]				R
18h	TOUCH4_YL	4 th TOUCH Y POSITION[7:0]								R	
19h										R	
1Ah										R	
1Bh	TOUCH5_XH	5 th EVENT FLAG				5 th TOUCH X POSITION[11:8]				R	
1Ch	TOUCH5_XL	5 th TOUCH X POSITION[7:0]								R	
1Dh	TOUCH5_YH	5 th TOUCH ID[3:0]					5 th TOUCH Y POSITION[11:8]				R
1Eh	TOUCH5_YL	5 th TOUCH Y POSITION[7:0]								R	
1Fh										R	
20h										R	
A6h	ID_G_FIRMID	FIRMWARE ID								R	

TD_STATUS

THIS REGISTER IS THE TOUCH DATA STATUS REGISTER.

ADDRESS	BIT ADDRESS	REGISTER NAME	DESCRIPTION
02h	3:0	NUMBER OF TOUCH POINTS [3:0]	HOW MANY POINTS DETECTED. 1-5 IS VALID.
	7:4	NONE	NONE

TOUCHn_XH (n:1-5)

THIS REGISTER DESCRIBES MSB OF THE X COORDINATE OF THE NTH TOUCH POINT AND THE CORRESPONDING EVENT FLAG.

ADDRESS	BIT ADDRESS	REGISTER NAME	DESCRIPTION
03h ~ 1Bh	7:6	EVENT FLAG	00b: PUT DOWN 01b: PUT UP 10b: CONTACT 11b: RESERVED
	5:4	NONE	RESERVED
	3:0	TOUCH X POSITION [11:8]	MSB OF TOUCH X POSITION IN PIXELS

TOUCHn_XL (n:1-5)

THIS REGISTER DESCRIBES LSB OF THE X COORDINATE OF THE NTH TOUCH POINT.

ADDRESS	BIT ADDRESS	REGISTER NAME	DESCRIPTION
04h ~ 1Ch	7:0	TOUCH X POSITION [7:0]	LSB OF THE TOUCH X POSITION IN PIXELS

TOUCHn_YH (n:1-5)

THIS REGISTER DESCRIBES MSB OF THE Y COORDINATE OF THE NTH TOUCH POINT AND CORRESPONDING TOUCH ID.

ADDRESS	BIT ADDRESS	REGISTER NAME	DESCRIPTION
05h ~ 1Dh	7:4	TOUCH ID [3:0]	TOUCH ID OF TOUCH POINT
	3:0	TOUCH X POSITION [11:8]	MSB OF TOUCH Y POSITION IN PIXELS

TOUCHn_YL (n:1-5)

THIS REGISTER DESCRIBES LSB OF THE Y COORDINATE OF THE NTH TOUCH POINT.

ADDRESS	BIT ADDRESS	REGISTER NAME	DESCRIPTION
06h ~ 1Eh	7:0	TOUCH X POSITION [7:0]	LSB OF THE TOUCH Y POSITION IN PIXELS

ID_G_FIRMWARE_ID

THIS REGISTER DESCRIBES THE FIRMWARE ID OF THE APPLICATION

ADDRESS	BIT ADDRESS	REGISTER NAME	DESCRIPTION
A6h	7:0	ID_G_FIRMWARE_ID	FIRMWARE VERSION

13. INSPECTION CRITERION

13.1 APPLICATION

THIS INSPECTION STANDARD IS TO BE APPLIED TO THE LCD MODULE DELIVERED FROM EMERGING DISPLAY TECHNOLOGIES CORP.(E.D.T) TO CUSTOMERS

13.2 INSPECTION CONDITIONS

13.2.1 (1)OBSERVATION DISTANCE : 45±5cm

(2)VIEWING ANGLE : ±45°

±15° (FOR SECTION WITHIN VIEWING AREA), REFER TO FIG.A

90° (FOR SECTION OUTSIDE OF VIEWING AREA), REF TO FIG.B

PERPENDICULAR TO MODULE SURFACE

VIEWING ANGLE SHOULD BE SMALLER THAN 45°



THE INSPECTION CRITERIA IS ACCORDING TO LINE OF SIGHT. INSPECTION SHALL BE MADE WITHIN THE HALF SECTION OF THE VIEWING CONE GENERATED BY LINE SEGMENT OF 45° WITH RESPECTS TO THE VERTICAL AXIS FROM CENTER VERTEX OF LCD, THE FLUORESCENT LAMP AND THE CONE AXIS MUST BE PERPENDICULAR TO THE LCD SURFACE.

IF THE DEFECTS ARE OUTSIDE OF VIEWING AREA, IT SHALL BE INSPECTED BY 90° WITH RESPECTS TO THE VERTICAL AXIS FROM EDGE OF VIEWING AREA.

13.2.2 ENVIRONMENT CONDITIONS :

AMBIENT TEMPERATURE		25±5°C
AMBIENT HUMIDITY		65±20%RH
AMBIENT ILLUMINATION	COSMETIC INSPECTION	600~800 Lux
	FUNCTIONAL INSPECTION	300~500 Lux
INSPECTION TIME		10 secs

13.2.3 INSPECTION LOT

QUANTITY PER DELIVERY LOT FOR EACH MODEL

13.2.4 INSPECTION METHOD

A SAMPLING INSPECTION SHALL BE MADE ACCORDING TO THE FOLLOWING PROVISIONS TO JUDGE THE ACCEPTABILITY

(a)APPLICABLE STANDARD :

ANSI/ ASQ Z1.4 NORMAL INSPECTION LEVEL II

(b)AQL : MAJOR DEFECT : AQL 0.65

MINOR DEFECT : AQL 1.0

13.3 DEFECTS CLASSIFICATION

TYPE OF DEFECT	INSPECTION ITEM	DEFECT FEATURE	AQL
MAJOR DEFECT	1.DISPLAY ON	<ul style="list-style-type: none"> • DEFECT TO MISS SPECIFIED DISPLAY FUNCTION, FOR ALL AND SPECIFIED DOTS EX: DISCONNECTION, SHORT CIRCUIT ETC 	0.65
	2.CTP FUNCTION	<ul style="list-style-type: none"> • NO FUNCTION • BROKEN LINE • FALSE TOUCH 	
	3.BACKLIGHT	<ul style="list-style-type: none"> • NO LIGHT • FLICKERING AND OTHER ABNORMAL ILLUMINATION 	
	4.DIMENSIONS	<ul style="list-style-type: none"> • SUBJECT TO INDIVIDUAL ACCEPTANCE SPECIFICATIONS 	
MINOR DEFECT	1.DISPLAY ZONE (VIEWING AREA)	<ul style="list-style-type: none"> • BLACK/WHITE SPOT / CIRCULAR TYPE • BUBBLES ON POLARIZER • NEWTON RING • BLACK/WHITE LINE / LINEAR TYPE • SCRATCH • CONTAMINATION • UNEVEN COLOR SPREAD 	1.0
	2.BEZEL ZONE	<ul style="list-style-type: none"> • STAINS • SCRATCHES • FOREIGN MATTER 	
	3.SOLDERING	<ul style="list-style-type: none"> • INSUFFICIENT SOLDER • SOLDERED IN INCORRECT POSITION • CONVEX SOLDERING SPOT • SOLDER BALLS • SOLDER SCRAPS 	
	4.DISPLAY ON (ALL ON)	<ul style="list-style-type: none"> • LIGHT LINE 	

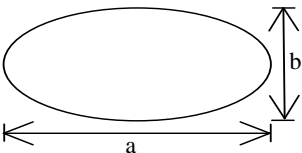
NO.	ITEM	CRITERIA																									
1	DISPLAY ON INSPECTION	1. INCORRECT PATTERN 2. MISSING SEGMENT 3. DIM SEGMENT 4. OPERATING VOLTAGE BEYOND SPEC																									
2	OVERALL DIMENSIONS	1. OVERALL DIMENSION BEYOND SPEC																									
3	DOT DEFECT	<p>1. INSPECTION PATTERN: FULL WHITE, FULL BLACK, RED, GREEN AND BLUE SCREENS.</p> <p>2.</p> <table border="1"> <thead> <tr> <th>ITEMS</th> <th>PERMISSIBLE NO.</th> </tr> </thead> <tbody> <tr> <td>BRIGHT DOT</td> <td>$N \leq 2$</td> </tr> <tr> <td>DARK DOT</td> <td>$N \leq 3$</td> </tr> <tr> <td>TOTAL BRIGHT AND DARK DOTS</td> <td>$N \leq 4$</td> </tr> </tbody> </table> <p>NOTE :</p> <p>(1)THE DEFINITION OF DOT : THE SIZE OF A DEFECTIVE DOT OVER 1/2 OF WHOLE DOT IS REGARDED AS ONE DEFECTIVE DOT.</p> <p>(2)BRIGHT DOT : DOTS APPEAR BRIGHT AND UNCHANGED IN SIZE IN WHICH LCD PANEL IS DISPLAYING UNDER BLACK PATTERN, THE BRIGHT DOT DEFECT MUST BE VISIBLE THROUGH 5% ND FILTER.</p> <p>(3)DARK DOT : DOTS APPEAR DARK AND UNCHANGED IN SIZE IN WHICH LCD PANEL IS DISPLAYING UNDER PURE RED, GREEN, BLUE PICTURE.</p>	ITEMS	PERMISSIBLE NO.	BRIGHT DOT	$N \leq 2$	DARK DOT	$N \leq 3$	TOTAL BRIGHT AND DARK DOTS	$N \leq 4$																	
ITEMS	PERMISSIBLE NO.																										
BRIGHT DOT	$N \leq 2$																										
DARK DOT	$N \leq 3$																										
TOTAL BRIGHT AND DARK DOTS	$N \leq 4$																										
4	BUBBLES ON POLARIZER /SURFACE STAINS /DIRT/CF FAIL/SPOT	<table border="1"> <thead> <tr> <th></th> <th>AVERAGE DIAMETER (mm) : D</th> <th>PERMISSIBLE NO.</th> </tr> </thead> <tbody> <tr> <td rowspan="3">BUBBLE ON POLARIZER</td> <td>$D \leq 0.25$</td> <td>IGNORE</td> </tr> <tr> <td>$0.25 < D \leq 0.5$</td> <td>$N \leq 5$</td> </tr> <tr> <td>$0.5 < D$</td> <td>NONE</td> </tr> <tr> <td rowspan="3">SURFACE STAINS / DIRT ON POLARIZER</td> <td>$D < 0.25$</td> <td>IGNORE</td> </tr> <tr> <td>$0.25 < D \leq 0.35$</td> <td>$N \leq 3$</td> </tr> <tr> <td>$0.35 < D$</td> <td>NONE</td> </tr> <tr> <td rowspan="2">CF FAIL / SPOT</td> <td>$D < 0.1$</td> <td>IGNORE</td> </tr> <tr> <td>$0.1 < D \leq 0.3$</td> <td>$N \leq 3$</td> </tr> <tr> <td></td> <td>$0.3 < D$</td> <td>NONE</td> </tr> </tbody> </table> <p>NOTE : (1)POLARIZER BUBBLE IS DEFINED AS THE BUBBLE APPEARS ON ACTIVE DISPLAY AREA. THE DEFECT OF POLARIZER BUBBLE SHALL BE IGNORED IF THE POLARIZER BUBBLE APPEARS ON THE OUTSIDE OF ACTIVE DISPLAY AREA.</p> <p>(2)THE EXTRANEIOUS SUBSTANCE IS DEFINED AS IT CAN BE OBSERVED WHEN THE MODULE IS POWER ON.</p> <p>(3)THE DEFINITION OF AVERAGE DIAMETER, D IS DEFINED AS FOLLOWING.</p> <p>AVERAGE DIAMETER (D)=(a+b)/2</p> 		AVERAGE DIAMETER (mm) : D	PERMISSIBLE NO.	BUBBLE ON POLARIZER	$D \leq 0.25$	IGNORE	$0.25 < D \leq 0.5$	$N \leq 5$	$0.5 < D$	NONE	SURFACE STAINS / DIRT ON POLARIZER	$D < 0.25$	IGNORE	$0.25 < D \leq 0.35$	$N \leq 3$	$0.35 < D$	NONE	CF FAIL / SPOT	$D < 0.1$	IGNORE	$0.1 < D \leq 0.3$	$N \leq 3$		$0.3 < D$	NONE
	AVERAGE DIAMETER (mm) : D	PERMISSIBLE NO.																									
BUBBLE ON POLARIZER	$D \leq 0.25$	IGNORE																									
	$0.25 < D \leq 0.5$	$N \leq 5$																									
	$0.5 < D$	NONE																									
SURFACE STAINS / DIRT ON POLARIZER	$D < 0.25$	IGNORE																									
	$0.25 < D \leq 0.35$	$N \leq 3$																									
	$0.35 < D$	NONE																									
CF FAIL / SPOT	$D < 0.1$	IGNORE																									
	$0.1 < D \leq 0.3$	$N \leq 3$																									
	$0.3 < D$	NONE																									

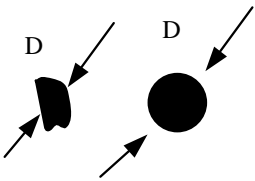
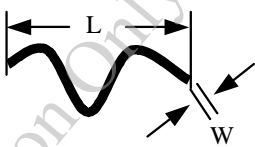
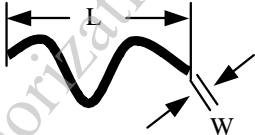
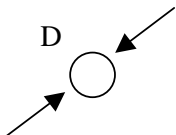
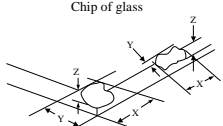
NO.	ITEM	CRITERIA											
5	BLACK/WHITE SPOT CIRCULAR TYPE	<p>THE FOLLOWING BLACK/WHITE SPOT ARE WITHIN THE VIEWING AREA. AVERAGE DIAMETER : D (mm)</p> <table border="1"> <thead> <tr> <th>SIZE D</th> <th>PERMISSIBLE NO.</th> </tr> </thead> <tbody> <tr> <td>$D \leq 0.15$</td> <td>IGNORE</td> </tr> <tr> <td>$0.15 < D \leq 0.5$</td> <td>4</td> </tr> <tr> <td>$D > 0.5$</td> <td>0</td> </tr> </tbody> </table> <p>NOTE (1) : THE DISTANCE BETWEEN DEFECTS SHOULD BE MORE THAN 5mm APART.</p> 		SIZE D	PERMISSIBLE NO.	$D \leq 0.15$	IGNORE	$0.15 < D \leq 0.5$	4	$D > 0.5$	0		
SIZE D	PERMISSIBLE NO.												
$D \leq 0.15$	IGNORE												
$0.15 < D \leq 0.5$	4												
$D > 0.5$	0												
6	SCRATCH	<p>THE FOLLOWING SCRATCH IS WITHIN THE VIEWING AREA. WIDTH : W (mm) , LENGTH : L (mm)</p> <table border="1"> <thead> <tr> <th>SIZE W & L</th> <th>PERMISSIBLE NO.</th> </tr> </thead> <tbody> <tr> <td>$W \leq 0.05$</td> <td>IGNORE</td> </tr> <tr> <td>$0.05 < W \leq 0.08, L \leq 5$</td> <td>3</td> </tr> <tr> <td>$0.08 < W \leq 0.1, L \leq 3$</td> <td>3</td> </tr> <tr> <td>$W > 0.1$</td> <td>0</td> </tr> </tbody> </table> <p>NOTE (1) : THE DISTANCE BETWEEN DEFECTS SHOULD BE MORE THAN 5mm APART.</p> 		SIZE W & L	PERMISSIBLE NO.	$W \leq 0.05$	IGNORE	$0.05 < W \leq 0.08, L \leq 5$	3	$0.08 < W \leq 0.1, L \leq 3$	3	$W > 0.1$	0
SIZE W & L	PERMISSIBLE NO.												
$W \leq 0.05$	IGNORE												
$0.05 < W \leq 0.08, L \leq 5$	3												
$0.08 < W \leq 0.1, L \leq 3$	3												
$W > 0.1$	0												
7	BLACK / WHITE LINE LINEAR TYPE / FOREIGN FIBER	<p>THE FOLLOWING BLACK LINE, WHITE LINE IS WITHIN THE VIEWING AREA. WIDTH : W (mm) , LENGTH : L (mm)</p> <table border="1"> <thead> <tr> <th>SIZE W & L</th> <th>PERMISSIBLE NO.</th> </tr> </thead> <tbody> <tr> <td>$W \leq 0.05$</td> <td>IGNORE</td> </tr> <tr> <td>$0.05 < W \leq 0.08, L \leq 5$</td> <td>2</td> </tr> <tr> <td>$0.08 < W \leq 0.1, L \leq 3$</td> <td>2</td> </tr> <tr> <td>$W > 0.1$</td> <td>0</td> </tr> </tbody> </table> <p>NOTE (1) : THE DISTANCE BETWEEN DEFECTS SHOULD BE MORE THAN 5mm APART.</p> 		SIZE W & L	PERMISSIBLE NO.	$W \leq 0.05$	IGNORE	$0.05 < W \leq 0.08, L \leq 5$	2	$0.08 < W \leq 0.1, L \leq 3$	2	$W > 0.1$	0
SIZE W & L	PERMISSIBLE NO.												
$W \leq 0.05$	IGNORE												
$0.05 < W \leq 0.08, L \leq 5$	2												
$0.08 < W \leq 0.1, L \leq 3$	2												
$W > 0.1$	0												
8	BUBBLE / DENT FOR OPTICAL BONDING	<p>BUBBLES WITHIN VIEWING AREA. AVERAGE DIAMETER : D (mm)</p> <table border="1"> <thead> <tr> <th>SIZE D</th> <th>PERMISSIBLE NO.</th> </tr> </thead> <tbody> <tr> <td>$D \leq 0.2$</td> <td>IGNORE</td> </tr> <tr> <td>$0.2 < D \leq 0.3$</td> <td>3</td> </tr> <tr> <td>$0.3 < D \leq 0.5$</td> <td>2</td> </tr> <tr> <td>$D > 0.5$</td> <td>0</td> </tr> </tbody> </table> <p>NOTE (1) : THE DISTANCE BETWEEN DEFECTS SHOULD BE MORE THAN 10mm APART.</p> 		SIZE D	PERMISSIBLE NO.	$D \leq 0.2$	IGNORE	$0.2 < D \leq 0.3$	3	$0.3 < D \leq 0.5$	2	$D > 0.5$	0
SIZE D	PERMISSIBLE NO.												
$D \leq 0.2$	IGNORE												
$0.2 < D \leq 0.3$	3												
$0.3 < D \leq 0.5$	2												
$D > 0.5$	0												
9	CHIPPING	<table border="1"> <tr> <td>CORNER</td> <td>$X + Y \leq 4\text{mm} \cdot Z \leq t$ (t : THICKNESS)</td> </tr> <tr> <td>EDGE</td> <td>$X \leq 6\text{mm} , Y \leq 1\text{mm} , Z < t$ (t : THICKNESS)</td> </tr> </table>	CORNER	$X + Y \leq 4\text{mm} \cdot Z \leq t$ (t : THICKNESS)	EDGE	$X \leq 6\text{mm} , Y \leq 1\text{mm} , Z < t$ (t : THICKNESS)	<p>Chip of glass</p> 						
CORNER	$X + Y \leq 4\text{mm} \cdot Z \leq t$ (t : THICKNESS)												
EDGE	$X \leq 6\text{mm} , Y \leq 1\text{mm} , Z < t$ (t : THICKNESS)												
10	CRACKED GLASS	NOT ACCEPTABLE											
11	LINE DEFECT ON DISPLAY	OBVIOUS VERTICAL OR HORIZONTAL LINE DEFECT IS NOT ALLOWED.											
12	MURA ON DISPLAY	IT'S ACCEPTABLE, IF MURA IS SLIGHT VISIBLE THROUGH 5% ND FILTER.											
13	UNEVEN COLOR SPREAD, COLORATION	TO BE DETERMINED BASED UPON THE LIMITED SAMPLE.											
14	BEZEL APPEARANCE	<p>1. BEZEL MAY NOT HAVE RUST, BE DEFORMED OR HAVE FINGER PRINTS STAINS OF OTHER CONTAMINATION.</p> <p>2. BEZEL MUST COMPLY WITH JOB SPECIFICATIONS.</p>											

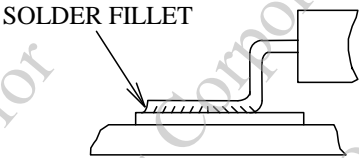
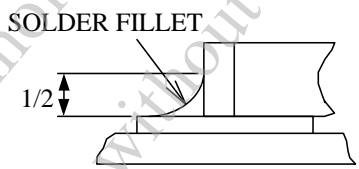
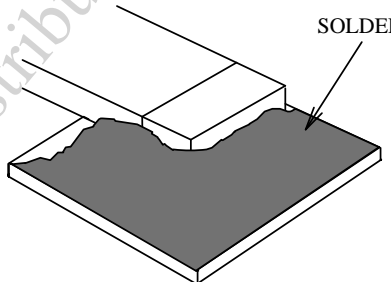
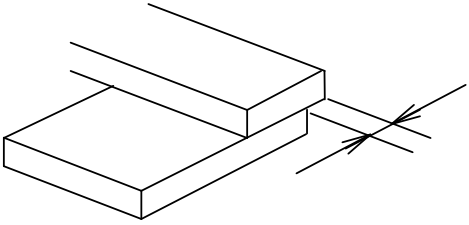
NO.	ITEM	CRITERIA
15	PCB	<ol style="list-style-type: none"> 1. THERE MAY NOT BE MORE THAN 2mm OF SEALANT OUTSIDE THE SEAL AREA ON THE PCB, AND THERE SHOULD BE NO MORE THAN THREE PLACES. 2. NO OXIDATION OR CONTAMINATION ON PCB TERMINALS. 3. PARTS ON PCB MUST BE THE SAME AS ON THE PRODUCTION CHARACTERISTIC CHART. THERE SHOULD BE NO WRONG PARTS, MISSING PARTS OR EXCESS PARTS. 4. THE JUMPER ON THE PCB SHOULD CONFORM TO THE PRODUCT CHARACTERISTIC CHART. 5. IF SOLDER GETS ON BEZEL TAB PADS, LED PAD, ZEBRA PAD OR SCREW HOLD PAD; MAKE SURE IT IS SMOOTHED DOWN.
16	SOLDERING	<ol style="list-style-type: none"> 1. NO SOLDERING FOUND ON THE SPECIFIED PLACE 2. INSUFFICIENT SOLDER <ol style="list-style-type: none"> (a) LSI, IC A POOR WETTING OF SOLDER IS BETWEEN LOWER BEND OR "HEEL" OF LEAD AND PAD  (b) CHIP COMPONENT <ul style="list-style-type: none"> · SOLDER IS LESS THAN 50% OF SIDES AND FRONT FACE WETTING  · SOLDER WETS 3 SIDES OF TERMINAL, BUT LESS THAN 25% OF SIDES AND FRONT SURFACE AREA ARE COVERED  3. PARTS ALIGNMENT <ol style="list-style-type: none"> (a) LSI, IC LEAD WIDTH IS MORE THAN 50% BEYOND PAD OUTLINE 

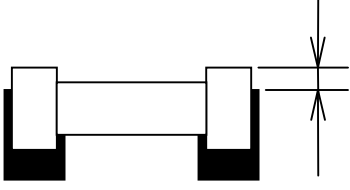
NO.	ITEM	CRITERIA
16	SOLDERING	<p>(b)CHIP COMPONENT COMPONENT IS OFF CENTER, AND MORE THAN 50% OF THE LEADS IS OFF THE PAD OUTLINE</p>  <p>4. NO UNMELTED SOLDER PASTE MAY BE PRESENT ON THE PCB. 5. NO COLD SOLDER JOINTS, MISSING SOLDER CONNECTIONS, OXIDATION OR ICICLE. 6. NO RESIDUE OR SOLDER BALLS ON PCB. 7. NO SHORT CIRCUITS IN COMPONENTS ON PCB.</p>
17	BACKLIGHT	<p>1. NO LIGHT 2. FLICKERING AND OTHER ABNORMAL ILLUMINATION 3. SPOTS OR SCRATCHES THAT APPEAR WHEN LIT MUST BE JUDGED USING LCD SPOT, LINES AND CONTAMINATION STANDARDS. 4. BACKLIGHT DOESN'T LIGHT OR COLOR IS WRONG.</p>
18	GENERAL APPEARANCE	<p>1. NO OXIDATION, CONTAMINATION, CURVES OR, BENDS ON INTERFACE PIN (OLB) OF TCP. 2. NO CRACKS ON INTERFACE PIN (OLB) OF TCP. 3. NO CONTAMINATION, SOLDER RESIDUE OR SOLDER BALLS ON PRODUCT. 4. THE IC ON THE TCP MAY NOT BE DAMAGED, CIRCUITS. 5. THE UPPERMOST EDGE OF THE PROTECTIVE STRIP ON THE INTERFACE PIN MUST BE PRESENT OR LOOK AS IF IT CAUSE THE INTERFACE PIN TO SEVER. 6. THE RESIDUAL ROSIN OR TIN OIL OF SOLDERING (COMPONENT OR CHIP COMPONENT) IS NOT BURNED INTO BROWN OR BLACK COLOR. 7. SEALANT ON TOP OF THE ITO CIRCUIT HAS NOT HARDENED. 8. PIN TYPE MUST MATCH TYPE IN SPECIFICATION SHEET. 9. LCD PIN LOOSE OR MISSING PINS. 10. PRODUCT PACKAGING MUST BE THE SAME AS SPECIFIED ON PACKAGING SPECIFICATION SHEET. 11. PRODUCT DIMENSION AND STRUCTURE MUST CONFORM TO PRODUCT SPECIFICATION SHEET. 12. THE APPEARANCE OF HEAT SEAL SHOULD NOT ADMIT ANY DIRT AND BREAK.</p>

NOTE :

- FOR ANY SPOTS OR LINES, WHICH ARE NOT OBSERVED UNDER APPROPRIATE PANEL OPERATING CONDITION ARE DEEMED ACCEPTABLE.
- THE FOREIGN MATERIALS THAT CAN BE BLOWN OUT BY AIR AND REMOVED BY WET CLEANING ARE NOT REGARDED AS DEFECTS.

14. RELIABILITY TEST

14.1 STANDARD SPECIFICATIONS FOR RELIABILITY OF LCD MODULE

NO.	ITEM	DESCRIPTION
1	HIGH TEMPERATURE OPERATION	THE SAMPLE SHOULD BE ALLOWED TO STAND AT +70°C FOR 240 HRS
2	LOW TEMPERATURE OPERATION	THE SAMPLE SHOULD BE ALLOWED TO STAND AT -20°C FOR 240 HRS
3	HIGH TEMPERATURE STORAGE	THE SAMPLE SHOULD BE ALLOWED TO STAND AT +80°C FOR 240 HRS
4	LOW TEMPERATURE STORAGE	THE SAMPLE SHOULD BE ALLOWED TO STAND AT -30°C FOR 240 HRS
5	HIGH TEMPERATURE /HUMIDITY TEST STORAGE	THE SAMPLE SHOULD BE ALLOWED TO STAND AT 60°C , 90% RH, 240 HRS
6	THERMAL SHOCK (NON-OPERATION)	<p>THE SAMPLE SHOULD BE ALLOWED TO STAND THE FOLLOWING 10 CYCLES OF OPERATION:</p> <p>The diagram shows a temperature profile for one cycle of thermal shock. It starts at -30°C, ramps up to +80°C (30 min), holds at +80°C (30 min), ramps down to -30°C (30 min), and holds at -30°C (30 min). The total duration is 120 minutes, labeled as 1 CYCLE.</p>
7	ESD (ELECTROSTATIC DISCHARGE) (NON-OPERATION)	AIR DISCHARGE ± 12KV CONTACT DISCHARGE ± 8KV (ACCORDING TO IEC-61000-4-2)

NOTE (1) : THE TEST SAMPLES HAVE RECOVERY TIME FOR 2 HOURS AT ROOM TEMPERATURE BEFORE THE FUNCTION CHECK. IN THE STANDARD CONDITIONS, THERE IS NO DISPLAY FUNCTION NG ISSUE OCCURRED.

14.2 TESTING CONDITIONS AND INSPECTION CRITERIA

FOR THE FINAL TEST THE TESTING SAMPLE MUST BE STORED AT ROOM TEMPERATURE FOR 24 HOURS, AFTER THE TESTS LISTED IN TABLE 14.1, STANDARD SPECIFICATIONS FOR RELIABILITY HAVE BEEN EXECUTED IN ORDER TO ENSURE STABILITY.

NO.	ITEM	TEST MODEL	INSPECTION CRITERIA
1	CURRENT CONSUMPTION	REFER TO SPECIFICATION	THE CURRENT CONSUMPTION SHOULD CONFORM TO THE PRODUCT SPECIFICATION.
2	CONTRAST	REFER TO SPECIFICATION	AFTER THE TESTS HAVE BEEN EXECUTED, THE CONTRAST MUST BE LARGER THAN HALF OF ITS INITIAL VALUE PRIOR TO THE TESTS.
3	APPEARANCE	VISUAL INSPECTION	DEFECT FREE

15. CAUTION

15.1 OPERATION

- 15.1.1 DO NOT CONNECT OR DISCONNECT MODULES TO OR FROM THE MAIN SYSTEM WHILE POWER IS BEING SUPPLIED .
- 15.1.2 USE THE MODULE WITHIN SPECIFIED TEMPERATURE ; LOWER TEMPERATURE CAUSES THE RETARDATION OF BLINKING SPEED OF THE DISPLAY ; HIGHER TEMPERATURE MAKES OVERALL DISPLAY DISCOLOR. WHEN THE TEMPERATURE RETURNS TO NORMALITY, THE DISPLAY WILL OPERATE NORMALLY .
- 15.1.3 ADJUST THE LC DRIVING VOLTAGE TO OBTAIN THE OPTIMUM CONTRAST.
- 15.1.4 POWER ON SEQUENCE INPUT SIGNALS SHOULD NOT BE SUPPLIED TO LCD MODULE BEFORE POWER SUPPLY VOLTAGE IS APPLIED AND REACHES THE SPECIFIED VALUE .
IF ABOVE SEQUENCE IS NOT FOLLOWED , CMOS LSIS OF LCD MODULES MAY BE DAMAGED DUE TO LATCH - UP PROBLEM .
- 15.1.5 NOT ALLOWED TO INFLICT ANY EXTERNAL STRESS AND TO CAUSE ANY MECHANICAL INTERFERENCE ON THE BENDING AREA OF FPC DURING THE TAIL BENDING BACKWARDS!
DO NOT STRESS FPC AND IC ON THE MODULE!

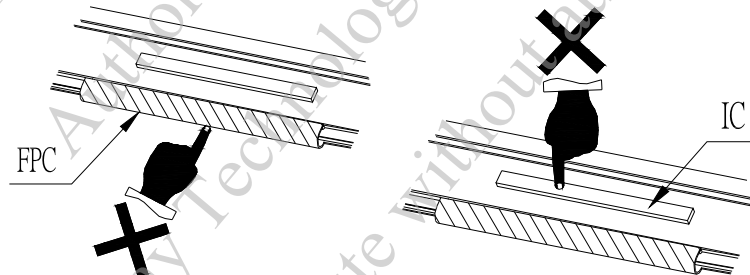

15.2 HANDLING

- 15.2.1 USE A GROUNDED SOLDERING IRON WHEN SOLDERING CONNECTOR I/O TERMINALS . FOR SOLDERING OR REPAIRING, TAKE PRECAUTION AGAINST THE TEMPERATURE OF THE SOLDERING IRON AND THE SOLDERING TIME TO PREVENT PEELING OFF THE THROUGH-HOLE-PAD .
- 15.2.2 DO NOT DISASSEMBLE . EDT SHALL NOT BE HELD RESPONSIBLE IF THE MODULE IS DISASSEMBLED AND UPON THE REASSEMBLY THE MODULE FAILED .
- 15.2.3 DO NOT CHARGE STATIC ELECTRICITY , AS THE CIRCUIT OF THIS MODULE CONTAINS CMOS LSIS. A WORKMAN'S BODY SHOULD ALWAYS BE STATIC-PROTECTED BY USE OF AN ESD STRAP. WORKING CLOTHES FOR SUCH PERSONNEL SHOULD BE OF STATIC-PROTECTED MATERIAL .
- 15.2.4 ALWAYS GROUND THE ELECTRICALLY-POWERED DRIVER BEFORE USING IT TO INSTALL THE LCD MODULE. WHILE CLEANING THE WORK STATION BY VACUUM CLEANER, DO NOT BRING THE SUCKING MOUTH NEAR THE MODULE ; STATIC ELECTRICITY OF THE ELECTRICALLY-POWERED DRIVER OR THE VACUUM CLEANER MAY DESTROY THE MODULE .
- 15.2.5 DON'T GIVE EXTERNAL SHOCK.
- 15.2.6 DON'T APPLY EXCESSIVE FORCE ON THE SURFACE.
- 15.2.7 LIQUID CRYSTAL IN LCD IS HAZARDOUS SUBSTANCE. MUST NOT LICK AND SWALLOW.
WHEN THE LIQUID IS ATTACH TO YOUR, SKIN, CLOTH ETC.
WASH IT OUT THOROUGHLY AND IMMEDIATELY.
- 15.2.8 DON'T OPERATE IT ABOVE THE ABSOLUTE MAXIMUM RATING.
- 15.2.9 STORAGE IN A CLEAN ENVIRONMENT, FREE FROM DUST, ACTIVE GAS, AND SOLVENT.
- 15.2.10 STORE WITHOUT ANY PHYSICAL LOAD.
- 15.2.11 REWIRING: NO MORE THAN 3 TIMES.