

EXAMINED BY : Justin Horng	EMERGING DISPLAY TECHNOLOGIES CORPORATION	FILE NO .CAS-0008327
APPROVED BY : Yung Chang Hu		ISSUE : AUG.05, 2016
		TOTAL PAGE : 32
		VERSION : 1

CUSTOMER ACCEPTANCE SPECIFICATIONS

MODEL NO. :

ETML070006CDK6
(GP)

FOR MESSRS :

CUSTOMER'S APPROVAL

DATE :

BY :

CONFIDENTIAL
Authorized for Emerging Display Technologies Corporation Only.
Do not distribute without authorization.

EMERGING DISPLAY
TECHNOLOGIES CORPORATION

MODEL NO.	VERSION	PAGE
ETML070006CDK6	1	0-1

RECORDS OF REVISION	DOC . FIRST ISSUE	AUG.05, 2016
---------------------	-------------------	--------------

DATE	REVISED PAGE NO.	SUMMARY
<p>CONFIDENTIAL</p> <p>Authorized for</p> <p>Emerging Display Technologies Corporation Only.</p> <p>Do not distribute without authorization.</p>		

TABLE OF CONTENTS

NO.	ITEM	PAGE
1.	GENERAL SPECIFICATIONS -----	1
2.	MECHANICAL SPECIFICATIONS -----	1, 2
3.	ABSOLUTE MAXIMUM RATINGS -----	3
4.	ELECTRICAL CHARACTERISTICS -----	4
5.	TIMING CHARACTERISTICS -----	5 ~ 9
6.	OPTICAL CHARACTERISTICS -----	10, 11
7.	OUTLINE DIMENSIONS -----	12
8.	BLOCK DIAGRAM -----	13
9.	DETAIL DRAWING OF DOT MATRIX -----	14
10.	INTERFACE SIGNALS -----	15 ~ 17
11.	POWER SUPPLY -----	18
12.	CAPACITIVE TOUCH PANEL SPECIFICATION -----	19 ~ 22
13.	INSPECTION CRITERION -----	23 ~ 32

CONFIDENTIAL
 Authorized for
 Emerging Display Technologies Corporation Only.
 Do not distribute without authorization.

1. GENERAL SPECIFICATIONS

1.1 DATA SHEETS FOR LCD PANEL CONTROLLER/DRIVER PLEASE REFER TO :

HIMAX HX8262-A
HIMAX HX8678-A

1.2 DATA SHEETS FOR CAPACITIVE TOUCH PANEL CONTROLLER/DRIVER PLEASE REFER TO :

HYCON HY4614

1.3 MATERIAL SAFETY DESCRIPTION

ASSEMBLIES SHALL COMPLY WITH EDT GREEN PRODUCT (GP) REQUIREMENTS, INCLUDING PROHIBITED MATERIALS/COMPONENTS CONTAINING LEAD, MERCURY, CADMIUM, HEXAVALENT CHROMIUM, POLYBROMINATED BIPHENYLS (PBB), POLYBROMINATED DIPHENYL ETHERS (PBDE), POLYCHLORINATED BIPHENYLS (PCB) CATEGORY, POLYCHLORINATED NAPHTHALENE (PCN) CATEGORY, POLYCHLORINATED TERPHENYLS (PCT) CATEGORY, CHLORINATED PARAFFINS (CP) CATEGORY, TRIBUTHYL TIN CATEGORY / TRIPHENYL TIN CATEGORY, ASBESTOS, SPECIFIC AZO COMPOUNDS, FORMALDEHYDE, POLYVINYL CHLORIDE (PVC) AND PVC BLENDS, OTHER BROMINATED ORGANIC COMPOUNDS AND OTHER CHLORINATED ORGANIC COMPOUNDS.

2. MECHANICAL SPECIFICATIONS

2.1 TFT LCD MODULE MECHANICAL SPECIFICATIONS

(1) DISPLAY SIZE	-----	7 inch
(2) NUMBER OF DOTS	-----	800W * (RGB) * 480H DOTS
(3) MODULE SIZE	-----	165W * 104.44H * 11.51D (MAX.) mm (WITHOUT FPC)
(4) ACTIVE AREA	-----	152.4W * 91.44H mm
(5) DOT SIZE	-----	0.0635W * 0.1905H mm
(6) PIXEL SIZE	-----	0.1905W * 0.1905H mm
(7) LCD TYPE	-----	TFT, TRANSMISSIVE , ANTE-GLARE
(8) COLOR	-----	262K
(9) VIEWING DIRECTION	-----	6 O'CLOCK (GRAY LEVEL INVERSION)
(10) BACK LIGHT	-----	LED, COLOR : WHITE
(11) INTERFACE MODE	-----	RGB(18BIT) PARALLEL (DE/SYNC MODE)

2.2 CAPACITIVE TOUCH PANEL MECHANICAL SPECIFICATIONS

- (1) TOUCH PANEL SIZE ----- 7.0 inch
- (2) OUTER DIMENSION ----- 165W * 104.21H * 1.3D mm
(WITHOUT FPC)
- (3) ACTIVE AREA ----- 155W * 93.05H mm
- (4) INPUT TYPE ----- MULTI TOUCH
- (5) NUMBER OF TOUCH SENSOR ----- 24*14 SENSORS
- (6) RESOLUTION ----- 1536 * 896
- (7) INTERFACE MODE ----- I2C

CONFIDENTIAL
Authorized for
Emerging Display Technologies Corporation Only.
Do not distribute without authorization.

3. ABSOLUTE MAXIMUM RATINGS

3.1 LCD MODULE ELECTRICAL ABSOLUTE MAXIMUM RATINGS

PARAMETER	SYMBOL	MIN.	MAX.	UNIT	REMARK
POWER SUPPLY VOLTAGE	VDD-VSS	-0.5	6.5	V	
INPUT VOLTAGE	VIN-VSS	-0.3	VDD+0.3	V	
LED BACKLIGHT POWER DISSIPATION	PD	—	6.48	W	
LED BACKLIGHT FORWARD CURRENT	IF	—	360	mA	

3.2 CAPACITIVE TOUCH PANEL ELECTRICAL ABSOLUTE MAXIMUM RATINGS

PARAMETER	SYMBOL	MIN.	MAX.	UNIT	REMARK
POWER SUPPLY FOR DRIVER IC	VDDI	-0.2	4.0	V	
DC INPUT VOLTAGE	VIN	-0.2	4.0	V	

3.3 ENVIRONMENTAL ABSOLUTE MAXIMUM RATINGS

ITEM	OPERATING		STORAGE		REMARK
	MIN.	MAX.	MIN.	MAX.	
AMBIENT TEMPERATURE	-20°C	70°C	-30°C	80°C	NOTE (1) , (2)
HUMIDITY	NOTE (3)		NOTE (3)		WITHOUT CONDENSATION
VIBRATION		2.45 m/s ² (0.25G)	—	11.76 m/s ² (1.2G)	10~100Hz XYZ DIRECTIONS 1Hr. EACH
SHOCK	—	29.4 m/s ² (3G)	—	490 m/s ² (50G)	10 ms XYZ DIRECTIONS 1 TIME EACH
CORROSIVE GAS	NOT ACCEPTABLE		NOT ACCEPTABLE		

NOTE (1) : Ta AT -30°C : 48HRS MAX.

80°C : 168HRS MAX.

NOTE (2) : BACKGROUND COLOR CHANGES SLIGHTLY DEPENDING ON AMBIENT TEMPERATURE THIS PHENOMENON IS REVERSIBLE.

NOTE (3) : Ta ≤ 60°C : 90%RH MAX (96HRS MAX).

Ta > 60°C : ABSOLUTE HUMIDITY MUST BE LOWER THAN THE HUMIDITY OF 90%RH AT 60°C(96HRS MAX).

4. ELECTRICAL CHARACTERISTICS

4.1 LCD MODULE ELECTRICAL CHARACTERISTICS

Ta = 25 °C

PARAMETER	SYMBOL	CONDITION	MIN.	TYP.	MAX.	UNIT	REMARK
POWER SUPPLY VOLTAGE	VDD-VSS	—	3.2	3.3	3.6	V	
POWER SUPPLY VOLTAGE FOR LED DRIVER	VCC-VSS	—	4.7	5.0	5.3	V	
LOW LEVEL INPUT VOLTAGE	VIL	—	0	—	0.3*VDD	V	NOTE (1)
HIGH LEVEL INPUT VOLTAGE	VIH	—	0.7*VDD	—	VDD	V	NOTE (1)
POWER SUPPLY CURRENT	IDD	VDD-VSS=3.3V	—	220	270	mA	NOTE (2)
POWER SUPPLY CURRENT FOR LED DRIVER	ICC	VCC-VSS=5.0V LED B/L=ON	—	600	750	mA	
LED LIFE TIME	—	I _{LED} =50mA (PER. LED)	70K	—	—	hrs	NOTE (5) NOTE (6)

NOTE (1) : APPLIED TO TERMINALS B5~B0, G5~G0, R5~R0, DCLK, HSYNC, VSYNC, ENB.

NOTE (2) : THE DISPLAY PATTERN IS ALL “WHITE”.

NOTE (3) : INTERNAL CIRCUIT DIAGRAM OF BACKLIGHT

$$(VF=V_{BL1+}(A1)-V_{BL1-}(K1)=V_{BL2+}(A2)-V_{BL2-}(K2)=V_{BL3+}(A3)-V_{BL3-}(K3))$$

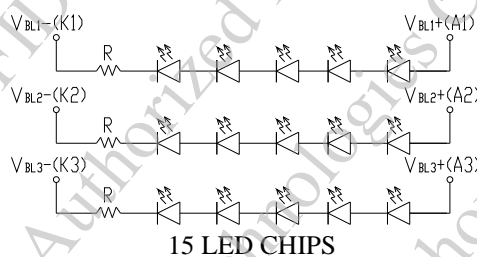

NOTE (4) : AMBIENT TEMP. VS. ALLOWABLE FORWARD CURRENT.(PER. LED)

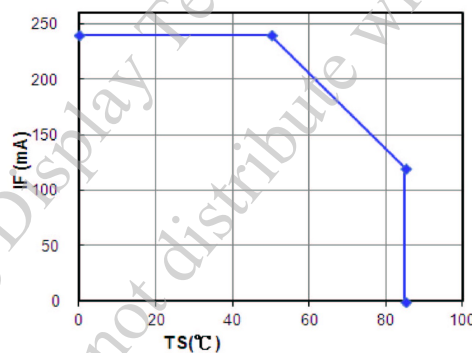

NOTE (5) : CONDITIONS; TA=25 °C, CONTINUOUS LIGHTING.

NOTE (6) : DEFINITIONS OF FAILURE

A. LCD LUMINANCE BECOMES HALF OF THE MINIMUM VALUE.

B. LED DOESN'T LIGHT NORMALLY.

4.2 CAPACITIVE TOUCH PANEL ELECTRICAL CHARACTERISTICS

Ta = 25 °C

ITEM	SYMBOL	CONDITION	MIN.	TYP.	MAX.	UNIT
POWER SUPPLY	VDD1	—	3.15	3.3	3.45	V
CURRENT CONSUMPTION FOR OPERATION	I _{DD1}	VDD1-VSS1=3.3V	—	15	23	mA
CURRENT CONSUMPTION FOR SLEEP MODE	I _{SB}	VDD1-VSS1=3.3V	—	50	100	μA

5. TIMING CHARACTERISTICS

5.1 LCD MODULE AC ELECTRICAL CHARACTERISTICS

PARAMETER	SYMBOL	SPEC			UNIT
		MIN.	TYP.	MAX.	
HSYNC SETUP TIME	T_{hst}	6	—	—	ns
HSYNC HOLD TIME	T_{hhd}	6	—	—	ns
VSYNC SETUP TIME	T_{vst}	6	—	—	ns
VSYNC HOLD TIME	T_{vhd}	6	—	—	ns
DATA SETUP TIME	T_{dsu}	6	—	—	ns
DATA HOLD TIME	T_{dhd}	6	—	—	ns
DE SETUP TIME	T_{esu}	6	—	—	ns
SOURCE OUTPUT SETTLING TIME	T_{ST}	—	—	15	μ s
SOURCE OUTPUT LOADING R	R_{SL}	—	2	—	K ohm
SOURCE OUTPUT LOADING C	C_{SL}	—	60	—	pF

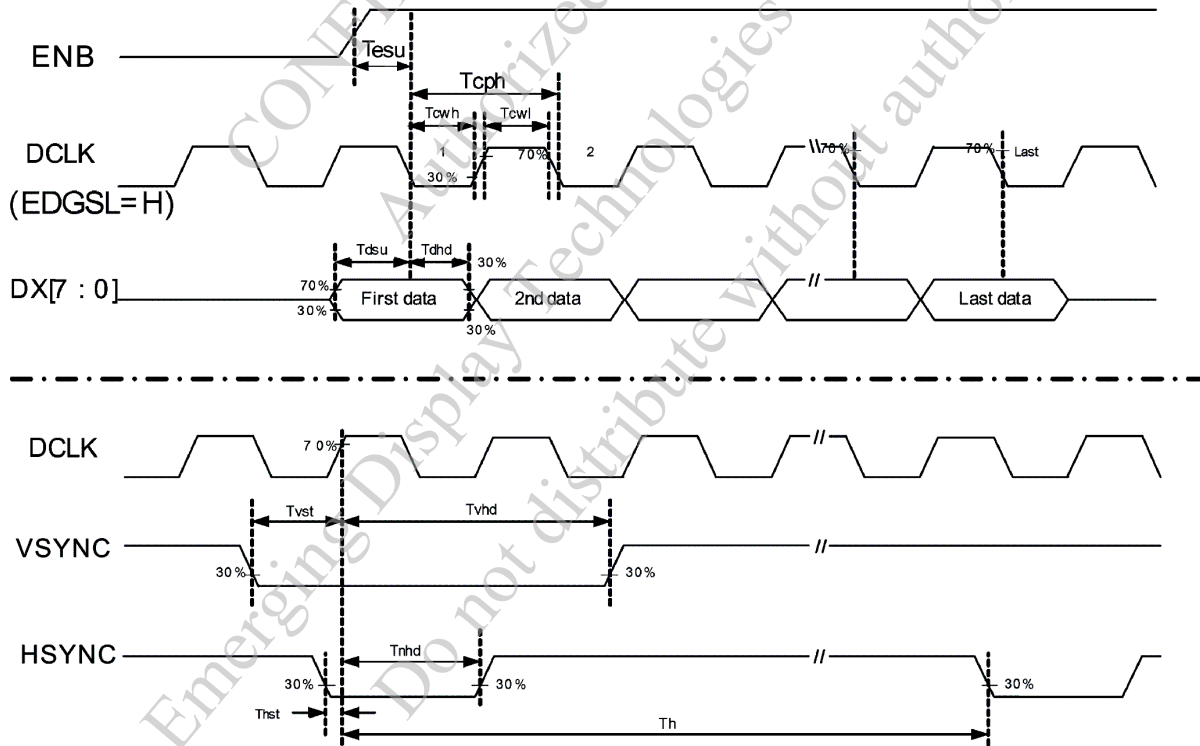

5.2 LCD MODULE SYNC MODE SIGNAL CHARACTERISTICS

PARAMETER	SYMBOL	SPEC			UNIT
		MIN.	TYP.	MAX.	
DCLK FREQUENCY	F_{CPH}	—	33.26	—	MHz
DCLK PERIOD	T_{CPH}	—	30.06	—	ns
DCLK PULSE DUTY	T_{CWH}	40	50	60	%
HSYNC PERIOD	T_H	930	1056	1057	T_{CPH}
HSYNC PULSE WIDTH	T_{WH}	1	128	—	T_{CPH}
HSYNC -FIRST HORIZONTAL DATA TIME	T_{HS}	—	216	—	T_{CPH}
HSYNC ACTIVE TIME	T_{HA}	—	800	—	T_{CPH}
VSYNC PERIOD	T_V	—	525	—	T_H
VSYNC PULSE WIDTH	T_{WV}	1	2	—	T_H
VSYNC -DE TIME	T_{VS}	—	35	—	T_H
VSYNC ACTIVE TIME	T_{VA}	—	480	—	T_H

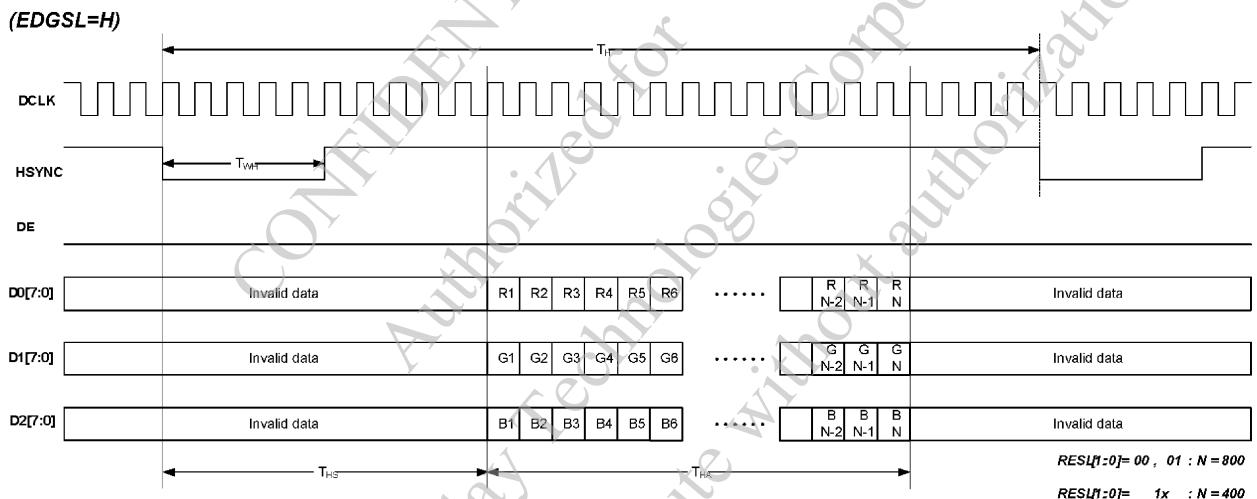

SYNC Mode Horizontal Data Format

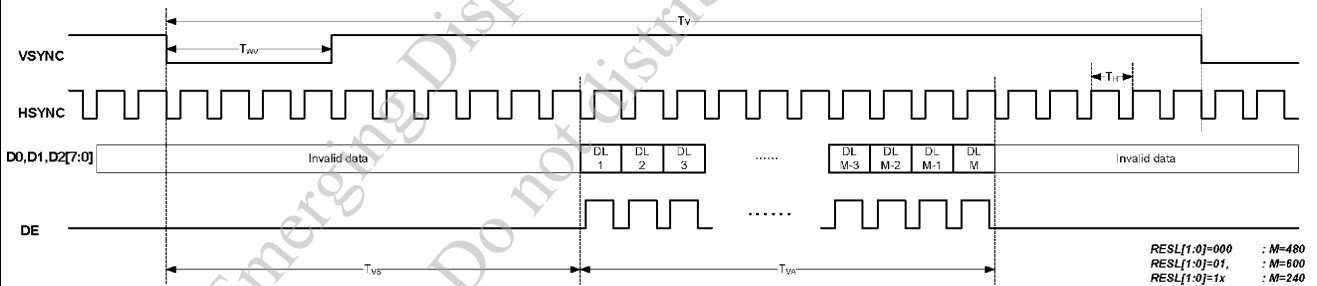

SYNC Mode Vertical Data Format

5.3 LCD MODULE DE MODE SIGNAL CHARACTERISTICS

PARAMETER	SYMBOL	SPEC			UNIT
		MIN.	TYP.	MAX.	
DCLK FREQUENCY	F_{CPH}	—	33.26	—	MHZ
DCLK PERIOD	T_{CPH}	—	30.06	—	ns
DCLK PULSE DUTY	T_{CWH}	40	50	60	%
DE PERIOD	$T_{DEH} + T_{DEL}$	1000	1056	1200	T_{CPH}
DE PULSE WIDTH	T_{DEH}	—	800	—	T_{CPH}
DE FRAME BLANKING	T_{DEB}	10	45	110	$T_{DEH} + T_{DEL}$
DE FRAME WIDTH	T_{DE}	—	480	—	$T_{DEH} + T_{DEL}$
OEV PULSE WIDTH	T_{OEV}	—	150	—	T_{CPH}
CKV PULSE WIDTH	T_{CKV}	—	133	—	T_{CPH}
DE(INTERNAL)-STV TIME	T_1	—	4	—	T_{CPH}
DE(INTERNAL)-CKV TIME	T_2	—	40	—	T_{CPH}
DE(INTERNAL)-OEV TIME	T_3	—	23	—	T_{CPH}
DE(INTERNAL)-POL TIME	T_4	—	157	—	T_{CPH}
STV PULSE WIDTH	—	—	1	—	T_H

NOTE (1) : $T_{HS} + T_{HA} < T_H$

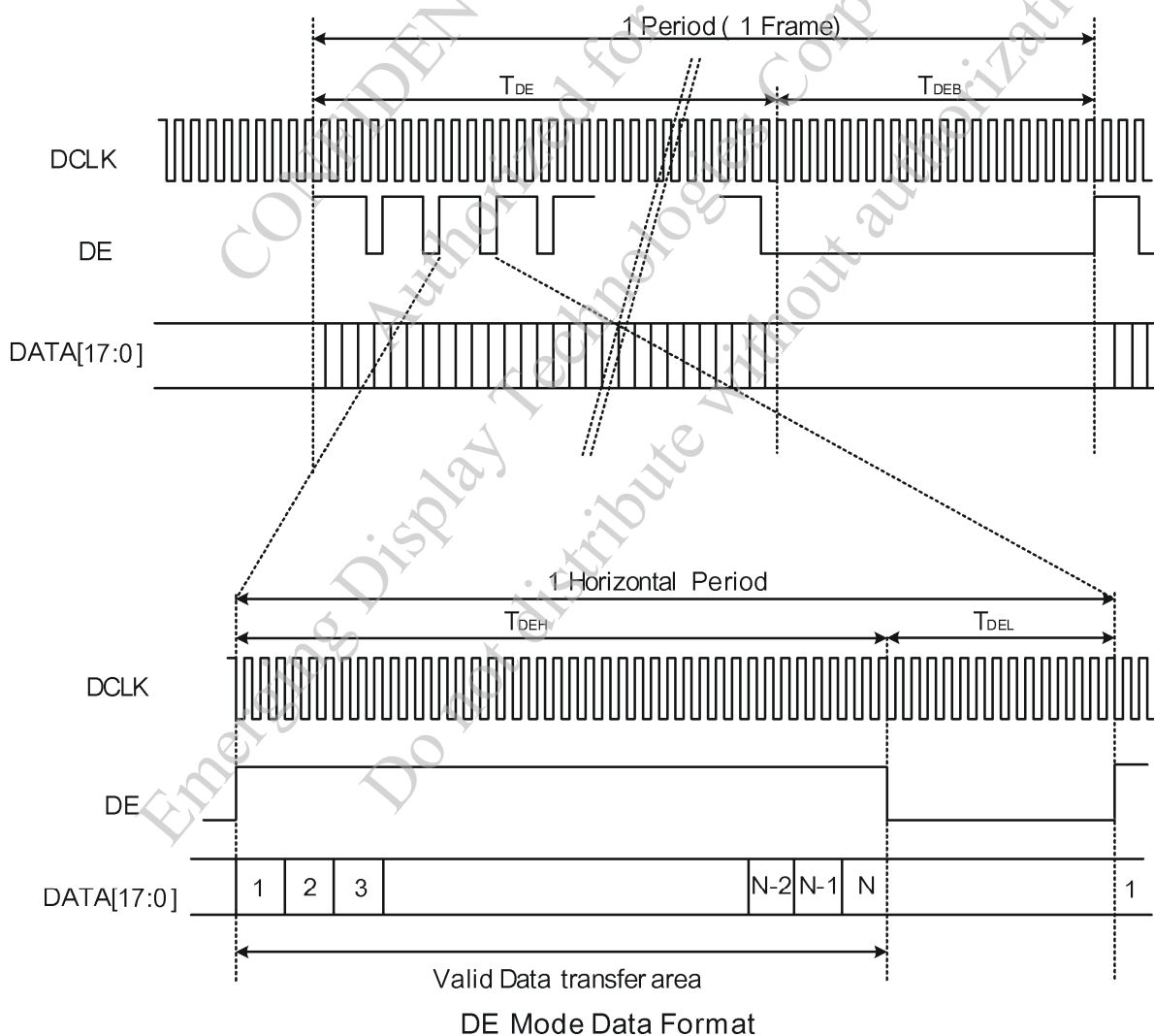

5.4 AC CHARACTERISTICS OF THE I2C SDA AND SCL PINS

ITEM	MIN.	TYP.	MAX.	UNIT
SCL FREQUENCY	0	—	400	KHz
BUS FREE TIME BETWEEN A STOP AND START CONDITION	1.3	—	—	us
HOLD TIME (REPEATED) START CONDITION	0.6	—	—	us
DATA SETUP TIME	100	—	—	ns
SETUP TIME FOR A REPEATED START CONDITION	0.6	—	—	us
SETUP TIME FOR STOP CONDITION	0.6	—	—	us

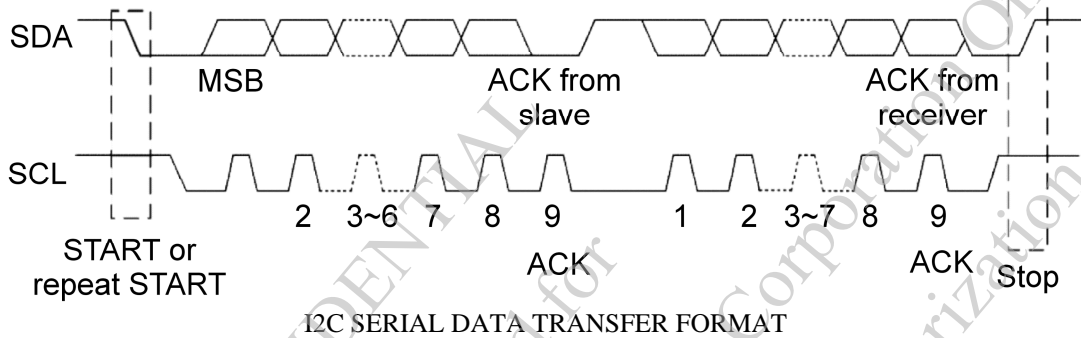

CONFIDENTIAL
 Authorized for
 Emerging Display Technologies Corporation Only.
 Do not distribute without authorization.

5.5 POWER SEQUENCE (CAPACITIVE TOUCH PANEL)

ITEM	SYMBOL	MIN.	TYP.	MAX.	UNIT
RISE TIME FROM 0.1VDD TO 0.9VDD	Tris	—	—	5	ms
TIME OF RESETTING TO BE LOW BEFORE POWERING ON	Trtp	100	—	—	us
TIME OF STARTING TO REPORT POINT AFTER POWERING ON	Tpon	200	—	—	ms
RESET TIME AFTER VDD POWERING ON	Tvdr	1	—	—	ms
TIME OF STARTING TO REPORT POINT AFTER RESETTING	Trsi	200	—	—	ms
RESET TIME	Trst	2	—	—	ms

POWER RISE TIMING

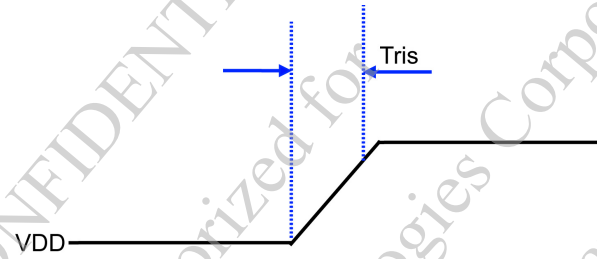

POWER ON / OFF TIMING

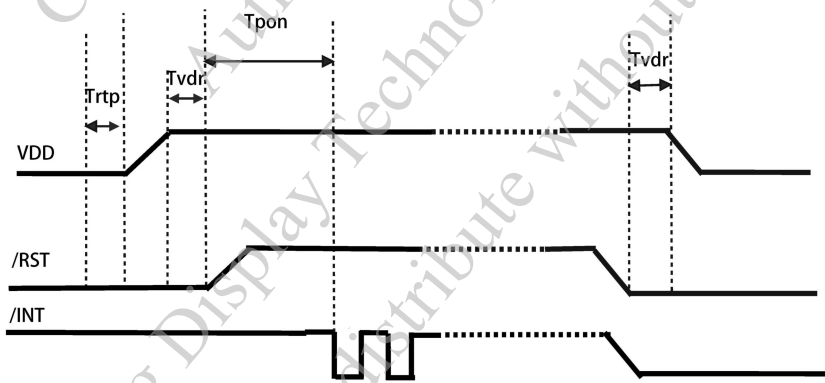

RESET SEQUENCE

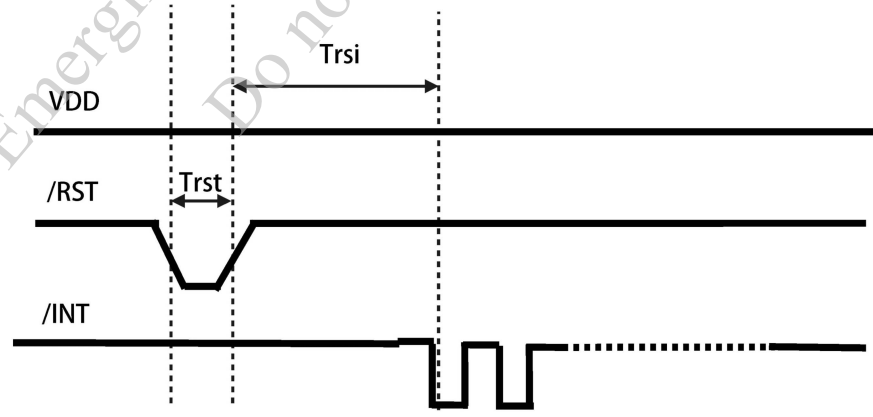

6. OPTICAL CHARACTERISTICS (NOTE 1)

6.1 OPTICAL CHARACTERISTICS

Ta = 25 ± 2 °C

ITEM	SYMBOL	CONDITION	MIN.	TYP.	MAX.	UNIT	REMARK	
VIEWING ANGLE	θ_{y+}	CR ≥ 10	$\theta_x=0^\circ$	65	70	—	deg.	NOTE (2) NOTE (3)
	θ_{y-}			70	75	—		
	θ_{x+}		$\theta_y=0^\circ$	70	75	—		
	θ_{x-}			70	75	—		
CONTRAST RATIO	CR	$\theta_x=0^\circ, \theta_y=0^\circ$	650	850	—		NOTE (3)	
RESPONSE TIME	T _R (rise)	$\theta_x=0^\circ, \theta_y=0^\circ$	—	5	10	msec	NOTE (4)	
	T _F (fall)		—	15	20			
THE BRIGHTNESS OF MODULE	B	$\theta_x=0^\circ, \theta_y=0^\circ$ VCC-VSS=5V	510	550	—	cd/m ²	NOTE (5)	
COLOR OF CIE COORDINATE	WHITE	W _x	$\theta_x=0^\circ, \theta_y=0^\circ$ VCC-VSS=5V NTSC : 72 %	0.265	0.315	0.365	—	NOTE (6)
		W _y		0.275	0.335	0.41		
	RED	R _x		0.58	0.63	0.68		
		R _y		0.305	0.355	0.405		
	GREEN	G _x		0.26	0.31	0.36		
		G _y		0.605	0.655	0.705		
	BLUE	B _x		0.135	0.175	0.225		
		B _y		0.04	0.06	0.11		
THE UNIFORMITY OF MODULE	—	$\theta_x=0^\circ, \theta_y=0^\circ$ VCC-VSS=5V	75	80	—	%	NOTE (5)	

NOTE (1) : TEST EQUIPMENT SETUP :

AFTER STABILIZING AND LEAVING THE PANEL ALONE AT A GIVEN TEMPERATURE FOR 30 MINUTES. MEASUREMENT SHOULD BE EXECUTED IN A STABLE, WINDLESS, AND DARK ROOM. OPTICAL SPECIFICATIONS ARE MEASURED BY TOPCON BM-7 (FAST) WITH A VIEWING ANGLE OF 1° AT A DISTANCE OF 50cm AND NORMAL DIRECTION.

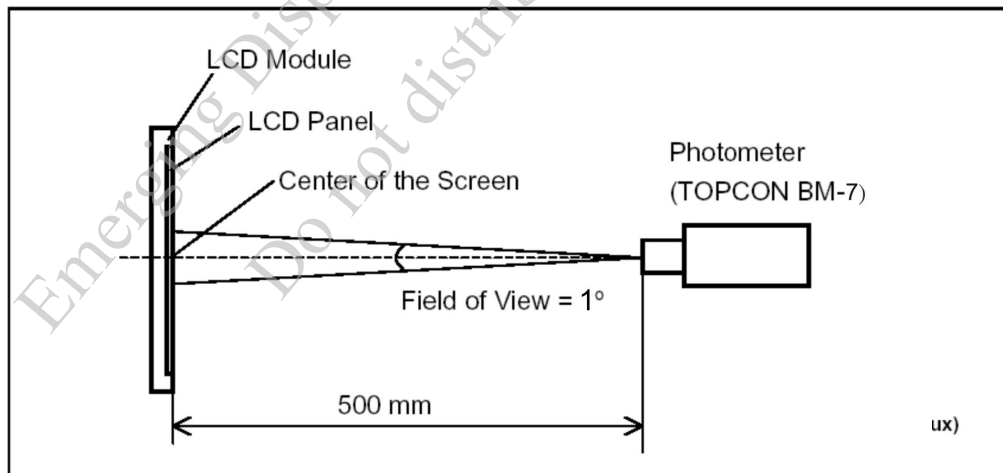

NOTE (2) : DEFINITION OF VIEWING ANGLE :

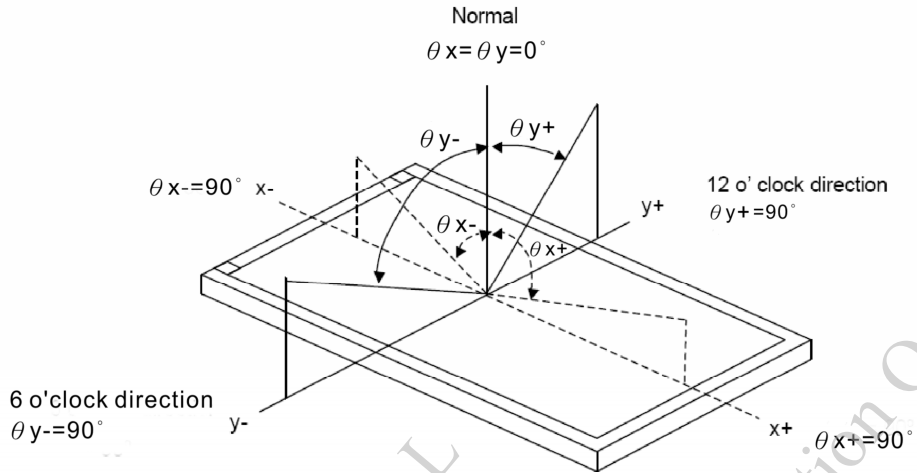

NOTE (3) : DEFINITION OF CONTRAST RATIO :

$$\text{CONTRAST RATIO (CR)} = \frac{\text{BRIGHTNESS MEASURED WHEN LCD IS AT " WHITE STATE "}}{\text{BRIGHTNESS MEASURED WHEN LCD IS AT " BLACK STATE "}}$$

NOTE (4) : DEFINITION OF RESPONSE TIME : TR AND TF

THE FIGURE BELOW IS THE OUTPUT SIGNAL OF THE PHOTO DETECTOR

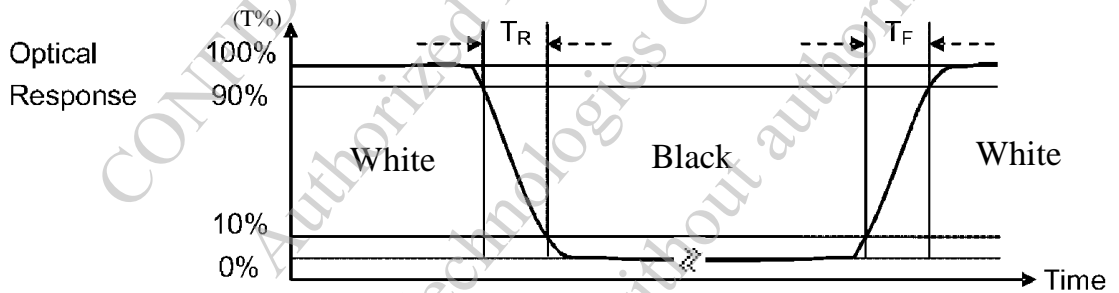

NOTE (5) : BRIGHTNESS MEASURED WHEN LCD IS AT "WHITE STATE"

NOTE (6) : THE 100% TRANSMISSION IS DEFINED AS THE TRANSMISSION OF LCD PANEL WHEN ALL THE INPUT TERMINALS OF MODULE ARE ELECTRICALLY OPENED.

6.2 THE TEST METHOD OF BRIGHTNESS AND UNIFORMITY

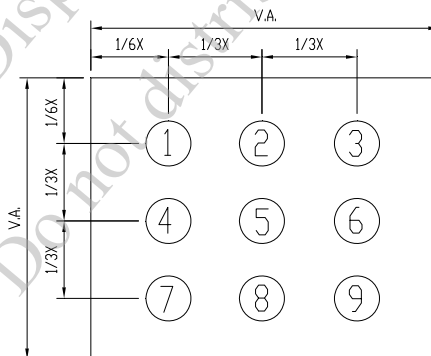

UNIT : mm

6.3 THE CALCULATING METHOD OF UNIFORMITY

$$\text{UNIFORMITY} : \left[1 - \frac{\text{MAXIMUM BRIGHTNESS} - \text{MINIMUM BRIGHTNESS}}{\text{AVERAGE BRIGHTNESS}} \right] \times 100\%$$

7. OUTLINE DIMENSIONS

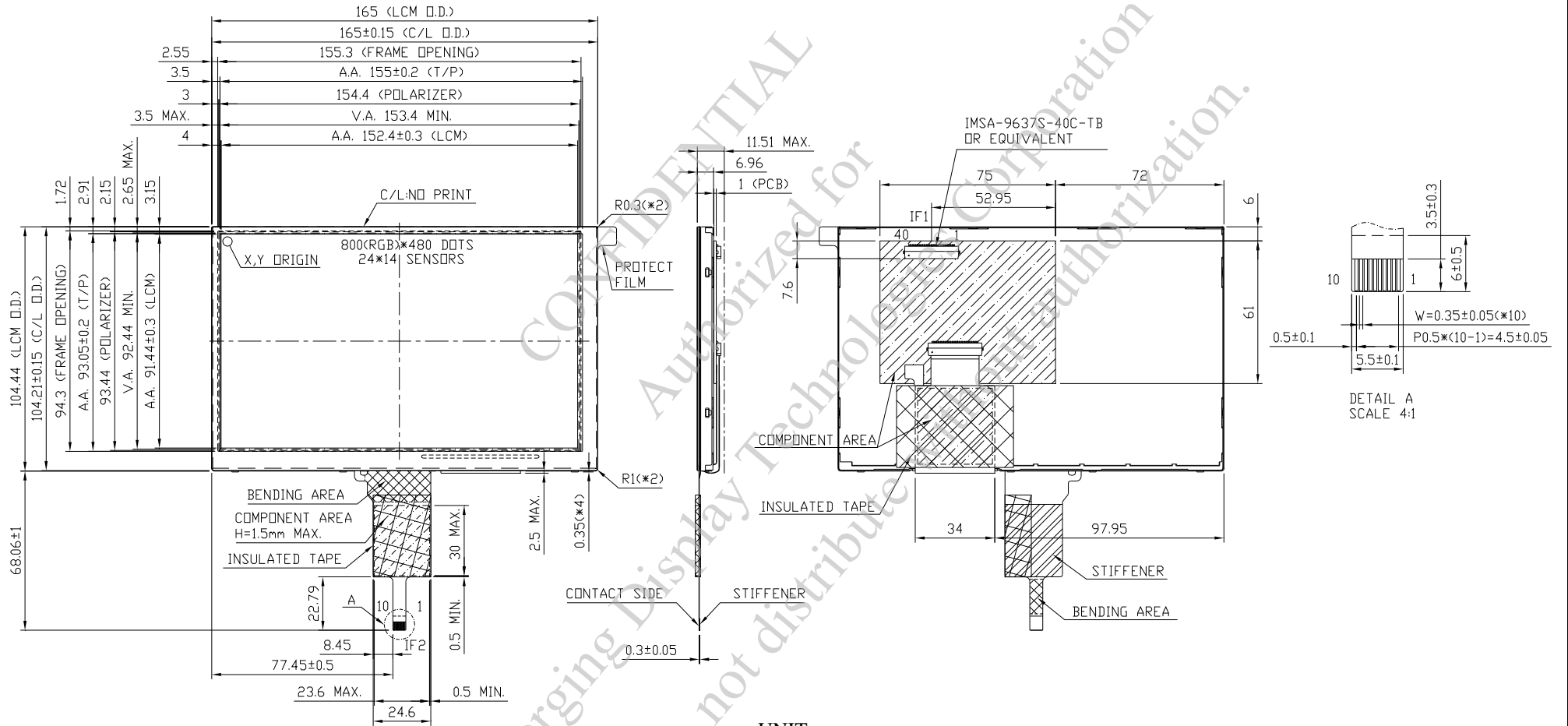

↑
VIEWING DIRECTION

Best Contrast but With Gray Level Inversion

UNIT : mm

SCALE : NTS

NOT SPECIFIED TOLERANCE IS ± 0.5

NOTE : IF2 : RECOMMEND MATCH CONNECTOR KYOCERA : 04 6240 010 SERIES

8. BLOCK DIAGRAM

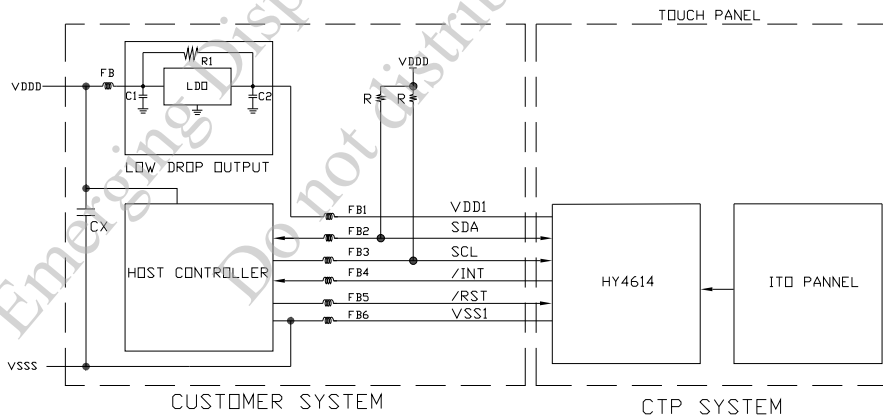
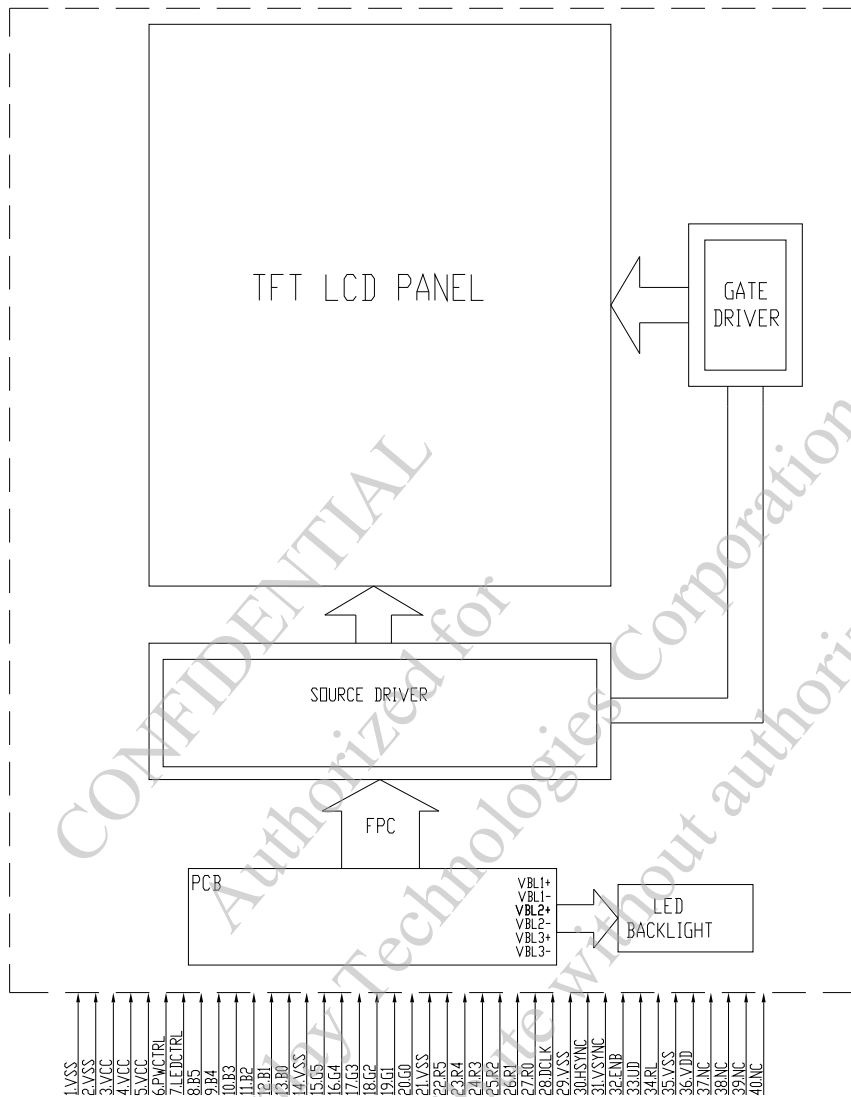

- NOTE (1) : THE STANDARD IIC COMMUNICATION INTERFACE, SUPREME SCL CLOCK IS 400 KHz, SLAVE ADDRESS CAN BE SET UP, SUPPORTS VDD LEVEL POWER, NEEDS PULL HIGH RESISTANCE AND WE RECOMMEND THE PULL HIGH RESISTANCE IS 2.0K OHM.
- NOTE (2) : POWER SUPPLY SHALL BE CLEAN AND NOISE FREE. ADDITIONAL FILTERING OR A SEPARATE LDO (LOW DROPOUT) REGULATOR CAN BE REQUIRED. C1 AND C2 CAPACITORS RECOMMENDATION : 4.7µF OR 10 µF LDO OUTPUT : MIN. 3.15V. VDDDD MIN. 3.15V + DROPOUT VOLTAGE OF LDO

9. DETAIL DRAWING OF DOT MATRIX

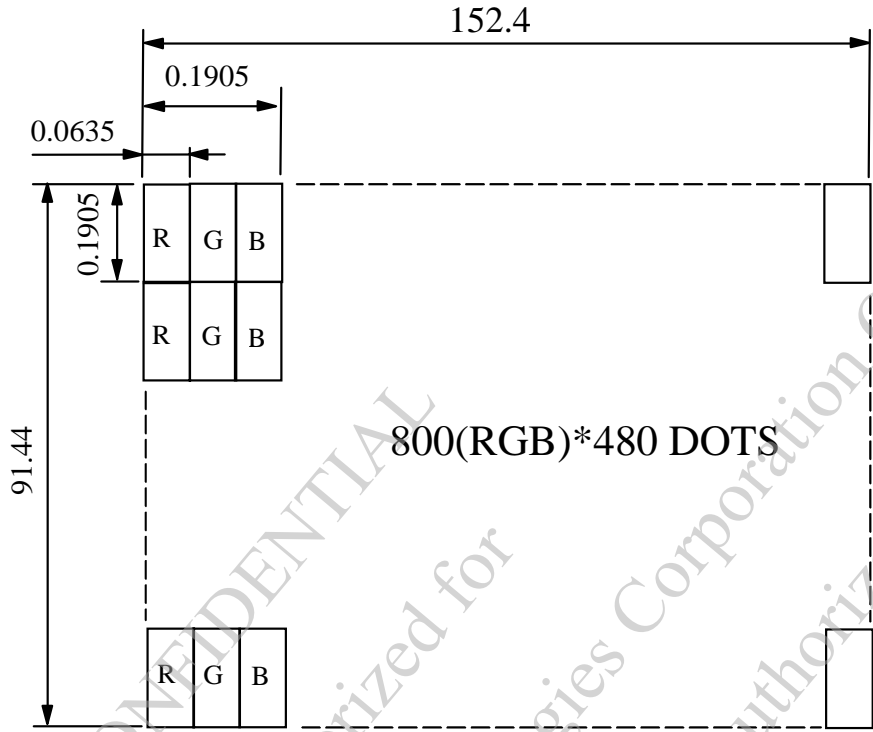

UNIT : mm
SCALE : NTS
NOT SPECIFIED TOLERANCE IS ± 0.1
DOTS MATRIX TOLERANCE IS ± 0.01

CONFIDENTIAL
Authorized for Emerging Display Technologies Corporation Only.
Do not distribute without authorization.

10. INTERFACE SIGNALS

10.1 IF1 INTERFACE

PIN NO.	SYMBOL	I/O	FUNCTION									
1	VSS	P	GROUND (VSS IS CONNECTED TO METAL HOUSING WITH CONDUCTIVE TAPE)									
2	VSS	P										
3	VCC	P	POWER SUPPLY FOR LED DRIVER CIRCUIT									
4	VCC	P	POWER SUPPLY FOR LED DRIVER CIRCUIT									
5	VCC	P	POWER SUPPLY FOR LED DRIVER CIRCUIT									
6	PWCTRL	I	<table border="1"> <thead> <tr> <th>LOGIC LEVEL</th> <th>PWCTRL</th> <th>REMARK</th> </tr> </thead> <tbody> <tr> <td>H=3.3V</td> <td>H</td> <td>POWER ON</td> </tr> <tr> <td>L=0V</td> <td>L</td> <td>SHUTDOWN</td> </tr> </tbody> </table>	LOGIC LEVEL	PWCTRL	REMARK	H=3.3V	H	POWER ON	L=0V	L	SHUTDOWN
			LOGIC LEVEL	PWCTRL	REMARK							
H=3.3V	H	POWER ON										
L=0V	L	SHUTDOWN										
7	LEDCTRL	I	BRIGHTNESS CONTROL FOR LED BACKLIGHT : POWER SUPPLY 0~2.5V OR PWM SIGNAL									
8	B5	I	BLUE DATA BIT 5									
9	B4	I	BLUE DATA BIT 4									
10	B3	I	BLUE DATA BIT 3									
11	B2	I	BLUE DATA BIT 2									
12	B1	I	BLUE DATA BIT 1									
13	B0	I	BLUE DATA BIT 0									
14	VSS	P	GROUND (VSS IS CONNECTED TO METAL HOUSING WITH CONDUCTIVE TAPE)									
15	G5	I	GREEN DATA BIT 5									
16	G4	I	GREEN DATA BIT 4									
17	G3	I	GREEN DATA BIT 3									
18	G2	I	GREEN DATA BIT 2									
19	G1	I	GREEN DATA BIT 1									
20	G0	I	GREEN DATA BIT 0									
21	VSS	P	GROUND (VSS IS CONNECTED TO METAL HOUSING WITH CONDUCTIVE TAPE)									
22	R5	I	RED DATA BIT 5									
23	R4	I	RED DATA BIT 4									
24	R3	I	RED DATA BIT 3									
25	R2	I	RED DATA BIT 2									
26	R1	I	RED DATA BIT 1									
27	R0	I	RED DATA BIT 0									
28	DCLK	I	DOT DATA CLOCK									
29	VSS	P	GROUND (VSS IS CONNECTED TO METAL HOUSING WITH CONDUCTIVE TAPE)									

PIN NO.	SYMBOL	I/O	FUNCTION	
30	HSYNC	I	HORIZONTAL SYNC INPUT. INTERNALLY PULL HIGH.	DE & SYNC MODE SETTING DE MODE : ONLY ENB AND PIXEL CLOCK IS NECESSARY. SYNC MODE : ENB SHOULD BE CONNECTED TO VSS. HSYNC/VSYNC AND PIXEL CLOCK IS NECESSARY.
31	VSYNC	I	VERTICAL SYNC INPUT. INTERNALLY PULL HIGH.	
32	ENB	I	DATA ENABLE INPUT. INTERNALLY PULL LOW.	
33	UD	I	U/D=H : OUT1→OUT2→-----→OUT480 U/D=L : OUT480→-----→OUT2→OUT1	
34	RL	I	R/L=H : OUT1→OUT2→-----→OUT800 R/L=L : OUT800→-----→OUT2→OUT1	
35	VSS	P	GROUND (VSS IS CONNECTED TO METAL HOUSING WITH CONDUCTIVE TAPE)	
36	VDD	P	POWER SUPPLY VOLTAGE	
37	NC	—	NC	
38	NC	—	NC	
39	NC	—	NC	
40	NC	—	NC	

10.2 SELECTION OF SCANNING MODE

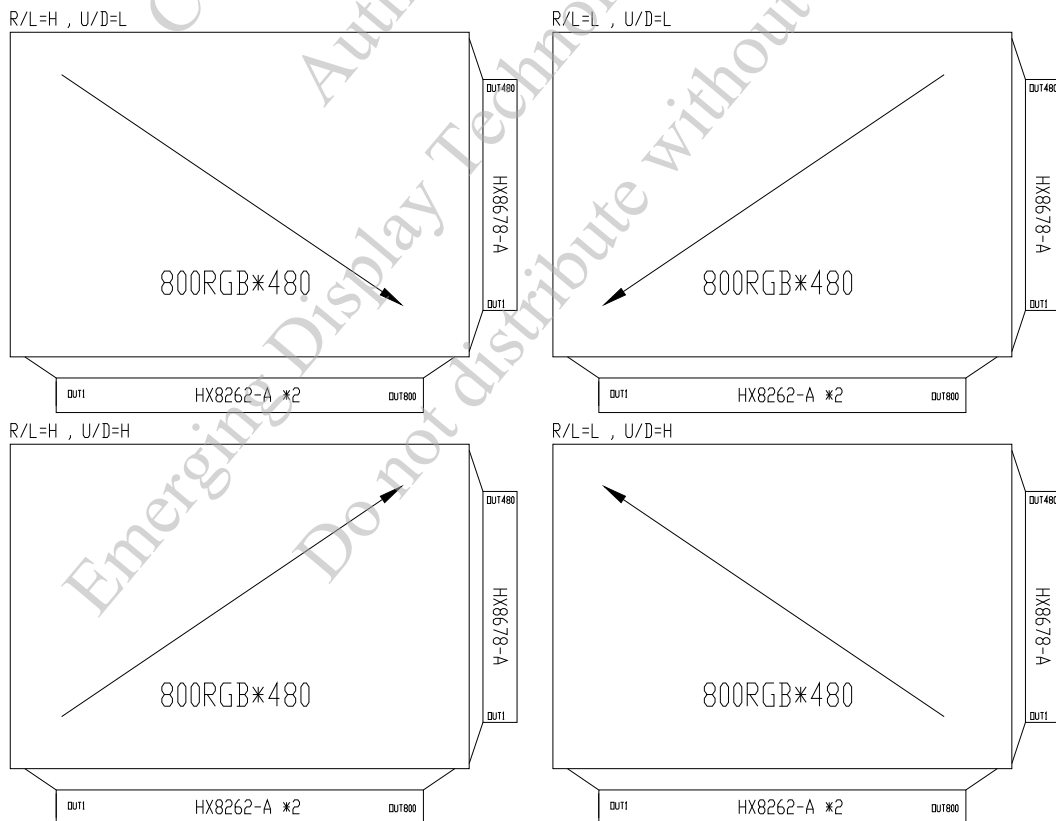

10.3 IF2 T/P SIGNAL INTERFACES

PIN NO.	SYMBOL	FUNCTION
1	VSS1	GROUND
2	VDD1	POWER SUPPLY VOLTAGE
3	SCL	I2C CLOCK INPUT
4	NC	NON CONNECTION
5	SDA	I2C DATA INPUT AND OUTPUT
6	NC	NON CONNECTION
7	/RST	EXTERNAL RESET, LOW IS ACTIVE
8	NC	NON CONNECTION
9	/INT	EXTERNAL INTERRUPT TO THE HOST
10	VSS1	GROUND

CONFIDENTIAL
Authorized for
Emerging Display Technologies Corporation Only.
Do not distribute without authorization.

11. POWER SUPPLY

11.1 POWER SUPPLY FOR LCM

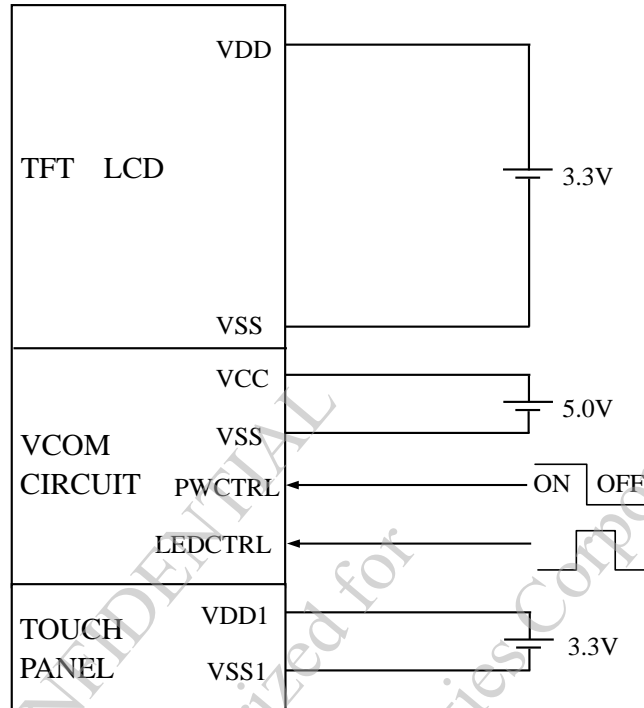

11.2 THE BRIGHTNESS CONTROLLED BY PWM SIGNAL OF LEDCTRL
(1) IF THE DUTY IS BIGGER, THE BRIGHTNESS WILL BE LOWER.

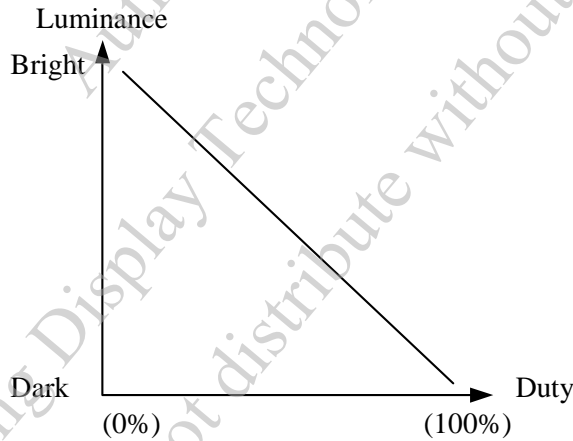

(2) SIGNAL OPERATION FREQUENCY IS 1K ~ 2KHz.

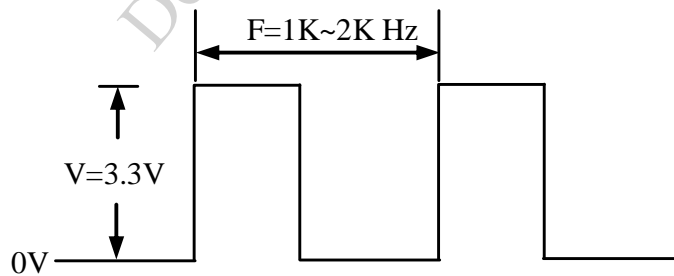

12. CAPACITIVE TOUCH PANEL SPECIFICATION

12.1 HARDNESS

ITEM	DESCRIPTION
SURFACE HARDNESS	7H (MIN)

12.2 PROTOCOL

12.2.1 I2C READ

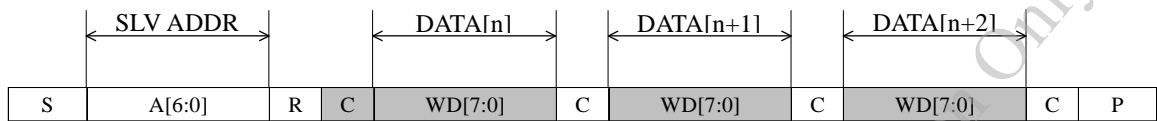

CHARACTER	DESCRIPTION
S	I2C START OR I2C RESTART
A[6:0]	SLAVE ADDRESS, THE VALUE CAN BE CUSTOMIZED
R	OPERATOR BYTE, SHOULD BE 1'b1, STANDS FOR READ
C	ACK SIGNAL
P	STOP SIGNAL (STOP SIGNAL IS OPTIONAL, RESTART SIGNAL IS ALSO OK FOR NEXT PACKET)

SLAVE ADDRESS=0x38

12.2.2 INTERRUPT SIGNAL FOR CTPM TO HOST

AS FOR STANDARD CTPM, HOST NEED TO USE BOTH INTERRUPT CONTROL SIGNAL AND SERIAL DATA INTERFACE TO GET THE TOUCH DATA.

HERE IS THE TIMING TO GET TOUCH DATA

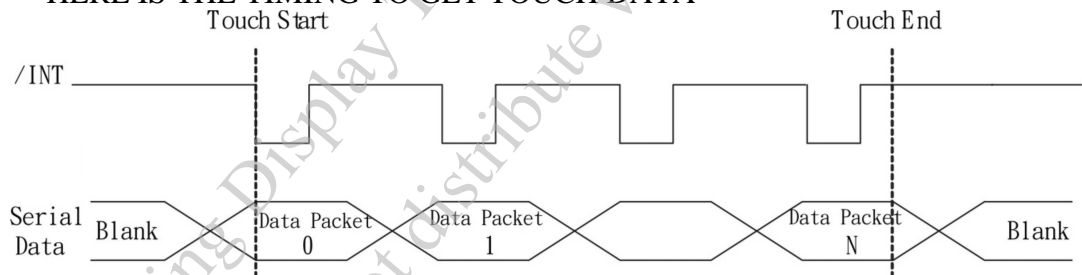

12.2.3 READ TOUCH DATA PACKET

WE DEFINED A CTPM PERIOD AS EACH CAPACITANCE DATA GATHERING AND DATA PROCESS, IN EACH CTPM, IF THERE IS A TOUCH DETECTS, THERE WILL WE A FAME OF TOUCH DATA. HOST CAN GET THE SPECIFIED FORMAT TOUCH DATA BY SERIAL DATA INTERFACE.

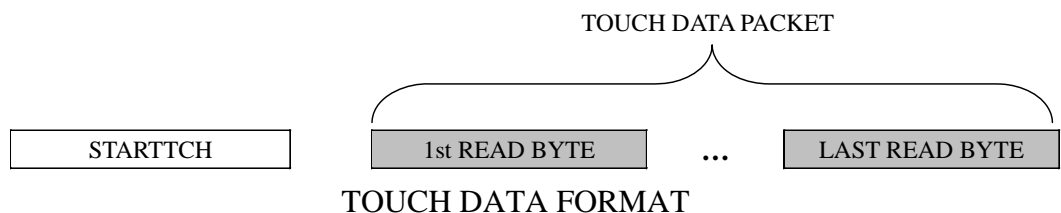

TOUCH DATA READ PROTOCOL

IN THIS MODE THE CTP IS FULLY FUNCTIONAL AS A TOUCH SCREEN CONTROLLER. READ AND WRITE ACCESS ADDRESS IS JUST LOGICAL ADDRESS WHICH IS NOT ENFORCED BY HARDWARE OR FIRMWARE. HERE IS THE OPERATING MODE REGISTER MAP.

ADDRESS	NAME	BIT7	BIT6	BIT5	BIT4	BIT3	BIT2	BIT1	BIT0	HOST ACCESS	
02h	TD_STATUS					NUMBER OF TOUCH POINTS[3:0]				R	
03h	TOUCH1_XH	1 st EVENT FLAG				1 st TOUCH X POSITION[11:8]				R	
04h	TOUCH1_XL	1 st TOUCH X POSITION[7:0]									R
05h	TOUCH1_YH	1 st TOUCH ID[3:0]				1 st TOUCH Y POSITION[11:8]				R	
06h	TOUCH1_YL	1 st TOUCH Y POSITION[7:0]									R
07h											
08h											
09h	TOUCH2_XH	2 nd EVENT FLAG				2 nd TOUCH X POSITION[11:8]				R	
0Ah	TOUCH2_XL	2 nd TOUCH X POSITION[7:0]									R
0Bh	TOUCH2_YH	2 nd TOUCH ID[3:0]				2 nd TOUCH Y POSITION[11:8]				R	
0Ch	TOUCH2_YL	2 nd TOUCH Y POSITION[7:0]									R
0Dh											R
0Eh											R
0Fh	TOUCH3_XH	3 rd EVENT FLAG				3 rd TOUCH X POSITION[11:8]				R	
10h	TOUCH3_XL	3 rd TOUCH X POSITION[7:0]									R
11h	TOUCH3_YH	3 rd TOUCH ID[3:0]				3 rd TOUCH Y POSITION[11:8]				R	
12h	TOUCH3_YL	3 rd TOUCH Y POSITION[7:0]									R
13h											R
14h											R
15h	TOUCH4_XH	4 th EVENT FLAG				4 th TOUCH X POSITION[11:8]				R	
16h	TOUCH4_XL	4 th TOUCH X POSITION[7:0]									R
17h	TOUCH4_YH	4 th TOUCH ID[3:0]				4 th TOUCH Y POSITION[11:8]				R	
18h	TOUCH4_YL	4 th TOUCH Y POSITION[7:0]									R
19h											R
1Ah											R
1Bh	TOUCH5_XH	5 th EVENT FLAG				5 th TOUCH X POSITION[11:8]				R	
1Ch	TOUCH5_XL	5 th TOUCH X POSITION[7:0]									R
1Dh	TOUCH5_YH	5 th TOUCH ID[3:0]				5 th TOUCH Y POSITION[11:8]				R	
1Eh	TOUCH5_YL	5 th TOUCH Y POSITION[7:0]									R
1Fh											R
20h											R
A6h	ID_G_FIRMID	FIRMWARE ID								R	

TD_STATUS

THIS REGISTER IS THE TOUCH DATA STATUS REGISTER.

ADDRESS	BIT ADDRESS	REGISTER NAME	DESCRIPTION
02h	3:0	NUMBER OF TOUCH POINTS [3:0]	HOW MANY POINTS DETECTED. 1-5 IS VALID.
	7:4	NONE	NONE

TOUCHn_XH (n:1-5)

THIS REGISTER DESCRIBES MSB OF THE X COORDINATE OF THE NTH TOUCH POINT AND THE CORRESPONDING EVENT FLAG.

ADDRESS	BIT ADDRESS	REGISTER NAME	DESCRIPTION
03h ~ 1Bh	7:6	EVENT FLAG	00b: PUT DOWN 01b: PUT UP 10b: CONTACT 11b: RESERVED
	5:4	NONE	RESERVED
	3:0	TOUCH X POSITION [11:8]	MSB OF TOUCH X POSITION IN PIXELS

TOUCHn_XL (n:1-5)

THIS REGISTER DESCRIBES LSB OF THE X COORDINATE OF THE NTH TOUCH POINT.

ADDRESS	BIT ADDRESS	REGISTER NAME	DESCRIPTION
04h ~ 1Ch	7:0	TOUCH X POSITION [7:0]	LSB OF THE TOUCH X POSITION IN PIXELS

TOUCHn_YH (n:1-5)

THIS REGISTER DESCRIBES MSB OF THE Y COORDINATE OF THE NTH TOUCH POINT AND CORRESPONDING TOUCH ID.

ADDRESS	BIT ADDRESS	REGISTER NAME	DESCRIPTION
05h ~ 1Dh	7:4	TOUCH ID [3:0]	TOUCH ID OF TOUCH POINT
	3:0	TOUCH X POSITION [11:8]	MSB OF TOUCH Y POSITION IN PIXELS

TOUCHn_YL (n:1-5)

THIS REGISTER DESCRIBES LSB OF THE Y COORDINATE OF THE NTH TOUCH POINT.

ADDRESS	BIT ADDRESS	REGISTER NAME	DESCRIPTION
06h ~ 1Eh	7:0	TOUCH X POSITION [7:0]	LSB OF THE TOUCH Y POSITION IN PIXELS

ID_G_FIRMWARE_ID

THIS REGISTER DESCRIBES THE FIRMWARE ID OF THE APPLICATION

ADDRESS	BIT ADDRESS	REGISTER NAME	DESCRIPTION
A6h	7:0	ID_G_FIRMWARE_ID	FIRMWARE VERSION

12.3 INSPECTION STANDARDS

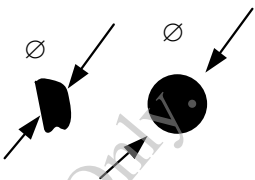
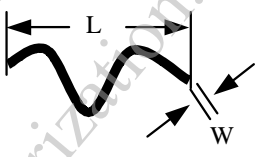
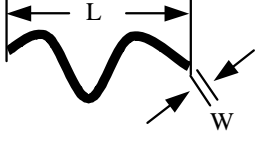
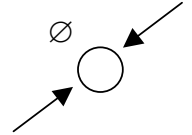
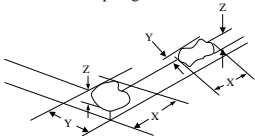
INSPECTION ITEMS	CRITERIA	REMARK	
BLACK/WHITE SPOT	THE FOLLOWING BLACK/WHITE SPOT ARE WITHIN THE VIEWING AREA. AVERAGE DIAMETER : D (mm)		
	SIZE D		PERMISSIBLE NO.
	D ≤ 0.1mm		IGNORE
	0.1mm < D ≤ 0.3mm		5
	0.3mm < D ≤ 0.5mm		5
D > 0.5 mm	0		
NOTE (1) : THE DISTANCE BETWEEN DOT DEFECTS SHOULD BE MORE THAN 10mm APART.			
SCRATCH	THE FOLLOWING BLACK LINE, WHITE LINE IS WITHIN THE VIEWING AREA. WIDTH : W (mm) , LENGTH : L (mm)		
	SIZE W & L		PERMISSIBLE NO.
	W ≤ 0.05mm		IGNORE
	0.05mm < W ≤ 0.07mm, L ≤ 5mm		1
W > 0.07mm	0		
LINEAR TYPE / FOREIGN FIBER	THE FOLLOWING BLACK LINE, WHITE LINE IS WITHIN THE VIEWING AREA. WIDTH : W (mm) , LENGTH : L (mm)		
	SIZE W & L		PERMISSIBLE NO.
	W ≤ 0.05mm		IGNORE
	0.05mm < W ≤ 0.07mm, L ≤ 5mm		1
W > 0.07mm	0		
BUBBLE / DENT	BUBBLES WITHIN VIEWING AREA. AVERAGE DIAMETER : D (mm)		
	SIZE D		PERMISSIBLE NO.
	D ≤ 0.2mm		IGNORE
	0.2mm < D ≤ 0.3mm		3
	0.3mm < D ≤ 0.5mm		1
D > 0.5mm	0		
CHIP DAMAGE ON GLASS	CORNER	X ≤ 3mm 、 Y ≤ 3mm 、 Z ≤ t (t : THICKNESS)	
	EDGE	X ≤ 6mm , Y ≤ 1mm , Z ≤ t (t : THICKNESS)	
		 <p>Chip of glass</p>	

NOTE :

- FOR ANY SPOTS OR LINES, WHICH ARE NOT OBSERVED UNDER APPROPRIATE PANEL OPERATING CONDITION ARE DEEMED ACCEPTABLE.
- THE FOREIGN MATERIALS THAT CAN BE BLOWN OUT BY AIR AND REMOVED BY WET CLEANING ARE NOT REGARDED AS DEFECTS.

13. INSPECTION CRITERION

13.1 APPLICATION

THIS INSPECTION STANDARD IS TO BE APPLIED TO THE LCD MODULE DELIVERED FROM EMERGING DISPLAY TECHNOLOGIES CORP.(E.D.T) TO CUSTOMERS.

13.2 INSPECTION CONDITIONS

13.2.1 (1)OBSERVATION DISTANCE : 35±5cm

(2)VIEW ANGLE :

NON-OPERATION CONDITION : ±5°

(PERPENDICULAR TO LCD PANEL SURFACE)

OPERATION CONDITION : ±45°

(PERPENDICULAR TO LCD PANEL SURFACE)

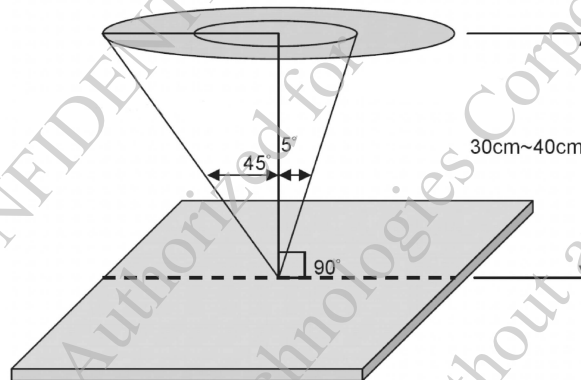

13.2.2 ENVIRONMENT CONDITIONS :

AMBIENT TEMPERATURE		20°C~25°C
AMBIENT HUMIDITY		65±20% RH
AMBIENT ILLUMINATION	COSMETIC INSPECTION	More than 600Lux
	FUNCTIONAL INSPECTION	300~500 Lux

13.2.3 INSPECTION LOT

QUANTITY PER DELIVERY LOT FOR EACH MODEL

13.2.4 INSPECTION METHOD

A SAMPLING INSPECTION SHALL BE MADE ACCORDING TO THE FOLLOWING PROVISIONS TO JUDGE THE ACCEPTABILITY

(A)APPLICABLE STANDARD : MIL-STD-105E

NORMAL INSPECTION, SINGLE SAMPLING
LEVEL II

(B)AQL : MAJOR DEFECT : AQL 0.65

MINOR DEFECT : AQL 1.0

13.3 INSPECTION STANDARDS

13.3.1 VISUAL DEFECTS CLASSIFICATION

TYPE OF DEFECT	INSPECTION ITEM	DEFECT FEATURE	AQL
MAJOR DEFECT	1.DISPLAY ON	<ul style="list-style-type: none"> • DEFECT TO MISS SPECIFIED DISPLAY FUNCTION, FOR ALL AND SPECIFIED DOTS EX: DISCONNECTION, SHORT CIRCUIT ETC 	0.65
	2.BACKLIGHT	<ul style="list-style-type: none"> • NO LIGHT • FLICKERING AND OTHER ABNORMAL ILLUMINATION 	
	3.DIMENSIONS	<ul style="list-style-type: none"> • SUBJECT TO INDIVIDUAL ACCEPTANCE SPECIFICATIONS 	
MINOR DEFECT	1.DISPLAY ZONE	<ul style="list-style-type: none"> • BLACK/WHITE SPOT • BUBBLES ON POLARIZER • NEWTON RING • BLACK/WHITE LINE • SCRATCH • CONTAMINATION • LEVER COLOR SPREAD 	1.0
	2.BEZEL ZONE	<ul style="list-style-type: none"> • STAINS • SCRATCHES • FOREIGN MATTER 	
	3.SOLDERING	<ul style="list-style-type: none"> • INSUFFICIENT SOLDER • SOLDERED IN INCORRECT POSITION • CONVEX SOLDERING SPOT • SOLDER BALLS • SOLDER SCRAPS 	
	4.DISPLAY ON (ALL ON)	<ul style="list-style-type: none"> • LIGHT LINE 	

13.3.2 MODULE DEFECTS CLASSIFICATION

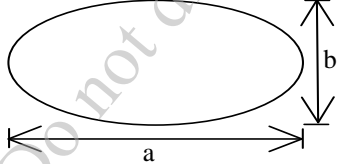
NO.	ITEM	CRITERIA												
1	DISPLAY ON INSPECTION	(1)INCORRECT PATTERN. (2)MISSING SEGMENT. (3)DIM SEGMENT. (4)OPERATING VOLTAGE BEYOND SPEC.												
2	OVERALL DIMENSIONS	(1)OVERALL DIMENSION BEYOND SPEC.												
3	DOT DEFECT	(1)INSPECTION PATTERN: FULL WHITE, FULL BLACK, RED, GREEN AND BLUE SCREENS. (2) <table border="1" style="margin-left: 20px;"> <thead> <tr> <th>ITEMS</th> <th>ACCEPTABLE COUNT</th> </tr> </thead> <tbody> <tr> <td>BRIGHT DOT</td> <td>$N \leq 3$</td> </tr> <tr> <td>DARK DOT</td> <td>$N \leq 5$</td> </tr> <tr> <td>TOTAL BRIGHT AND DARK DOTS</td> <td>$N \leq 5$</td> </tr> </tbody> </table> <p>NOTE : 1. THE DEFINITION OF DOT : THE SIZE OF A DEFECTIVE DOT OVER 1/2 OF WHOLE DOT IS REGARDED AS ONE DEFECTIVE DOT. 2. BRIGHT DOT : DOTS APPEAR BRIGHT AND UNCHANGED IN SIZE IN WHICH LCD PANEL IS DISPLAYING UNDER BLACK PATTERN. 3. DARK DOT : DOTS APPEAR DARK AND UNCHANGED IN SIZE IN WHICH LCD PANEL IS DISPLAYING UNDER PURE RED, GREEN, BLUE PICTURE.</p>	ITEMS	ACCEPTABLE COUNT	BRIGHT DOT	$N \leq 3$	DARK DOT	$N \leq 5$	TOTAL BRIGHT AND DARK DOTS	$N \leq 5$				
ITEMS	ACCEPTABLE COUNT													
BRIGHT DOT	$N \leq 3$													
DARK DOT	$N \leq 5$													
TOTAL BRIGHT AND DARK DOTS	$N \leq 5$													
4	FOREIGN BLACK/WHITE/ BRIGHT LINE/ SCRATCH OF VIEWING AREA	<table border="1" style="margin-left: 20px;"> <thead> <tr> <th>LENGTH : L</th> <th>WIDTH : W</th> <th>PERMISSIBLE NO.</th> </tr> </thead> <tbody> <tr> <td>$L \leq 0.3$</td> <td>$W \leq 0.05$</td> <td>IGNORE</td> </tr> <tr> <td>$0.3 < L \leq 2.5$</td> <td>$0.05 < W \leq 0.1$</td> <td>4</td> </tr> <tr> <td>$2.5 < L$</td> <td>$0.1 < W$</td> <td>NONE</td> </tr> </tbody> </table> <p>WIDTH : W mm, LENGTH : L mm</p>	LENGTH : L	WIDTH : W	PERMISSIBLE NO.	$L \leq 0.3$	$W \leq 0.05$	IGNORE	$0.3 < L \leq 2.5$	$0.05 < W \leq 0.1$	4	$2.5 < L$	$0.1 < W$	NONE
LENGTH : L	WIDTH : W	PERMISSIBLE NO.												
$L \leq 0.3$	$W \leq 0.05$	IGNORE												
$0.3 < L \leq 2.5$	$0.05 < W \leq 0.1$	4												
$2.5 < L$	$0.1 < W$	NONE												
5	FOREIGN MATTER \ BLACK SPOTS \ WHITE SPOTS \ DENT (INCLUDING LIGHT LEAKAGE DUE TO POLARIZING PLATES PINHOLES, ETC.)	<table border="1" style="margin-left: 20px;"> <thead> <tr> <th>AVERAGE DIAMETER (mm): D</th> <th>NUMBER OF PIECES PERMITTED</th> </tr> </thead> <tbody> <tr> <td>$D \leq 0.15$</td> <td>IGNORE</td> </tr> <tr> <td>$0.15 < D \leq 0.5$</td> <td>4</td> </tr> <tr> <td>$0.5 < D$</td> <td>NONE</td> </tr> </tbody> </table> <p>NOTE : DIAMETER $D=(a+b)/2$</p> 	AVERAGE DIAMETER (mm): D	NUMBER OF PIECES PERMITTED	$D \leq 0.15$	IGNORE	$0.15 < D \leq 0.5$	4	$0.5 < D$	NONE				
AVERAGE DIAMETER (mm): D	NUMBER OF PIECES PERMITTED													
$D \leq 0.15$	IGNORE													
$0.15 < D \leq 0.5$	4													
$0.5 < D$	NONE													

NO.	ITEM	CRITERIA		
			AVERAGE DIAMETER (mm) : D	NUMBER OF PIECES PERMITTED
6	BUBBLES OF POLARIZER /DIRT/CF FAIL /SURFACE STAINS	BUBBLE ON THE POLARIZER	$D \leq 0.25$	IGNORE
			$0.25 < D \leq 0.5$	$N \leq 5$
			$0.5 < D$	NONE
		SURFACE STAINS	$D < 0.1 \text{ mm}$	IGNORE
			$0.1 < D \leq 0.3\text{mm}$	$N \leq 3$
		CF FAIL / SPOT	$D < 0.1 \text{ mm}$	IGNORE
$0.1 < D \leq 0.3\text{mm}$	$N \leq 3$			
<p>NOTE : (1)POLARIZER BUBBLE IS DEFINED AS THE BUBBLE APPEARS ON ACTIVE DISPLAY AREA. THE DEFECT OF POLARIZER BUBBLE SHALL BE IGNORED IF THE POLARIZER BUBBLE APPEARS ON THE OUTSIDE OF ACTIVE DISPLAY AREA.</p> <p>(2)THE EXTRANEIOUS SUBSTANCE IS DEFINED AS IT CAN BE OBSERVED WHEN THE MODULE IS POWER ON.</p> <p>(3)THE DEFINITION OF AVERAGE DIAMETER, D IS DEFINED AS FOLLOWING.</p> <p>AVERAGE DIAMETER (D)=(a+b)/2</p> 				
7	LINE DEFECT ON DISPLAY	OBVIOUS VERTICAL OR HORIZONTAL LINE DEFECT IS NOT ALLOWED.		
8	MURA ON DISPLAY	NOT VISIBLE THROUGH 6% ND FILTER OR JUDGED BY LIMIT. SAMPLE IF NECESSARY.		
9	UNEVEN COLOR SPREAD, COLORATION	(1)TO BE DETERMINED BASED UPON THE STANDARD SAMPLE.		
10	BEZEL APPEARANCE	(1)BEZEL MAY NOT HAVE RUST, BE DEFORMED OR HAVE FINGER PRINTS STAINS OF OTHER CONTAMINATION. (2)BEZEL MUST COMPLY WITH JOB SPECIFICATIONS.		
11	PCB	<p>(1)THERE MAY NOT BE MORE THAN 2mm OF SEALANT OUTSIDE THE SEAL AREA ON THE PCB, AND THERE SHOULD BE NO MORE THAN THREE PLACES.</p> <p>(2)NO OXIDATION OR CONTAMINATION PCB TERMINALS.</p> <p>(3)PARTS ON PCB MUST BE THE SAME AS ON THE PRODUCTION CHARACTERISTIC CHART. THERE SHOULD BE NO WRONG PARTS, MISSING PARTS OR EXCESS PARTS.</p> <p>(4)THE JUMPER ON THE PCB SHOULD CONFORM TO THE PRODUCT CHARACTERISTIC CHART.</p> <p>(5)IF SOLDER GETS ON BEZEL TAB PADS, LED PAD, ZEBRA PAD OR SCREW HOLD PAD; MAKE SURE IT IS SMOOTHED DOWN.</p>		

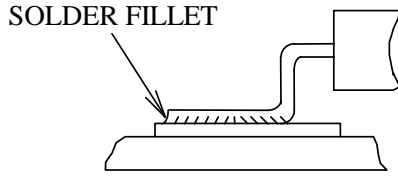
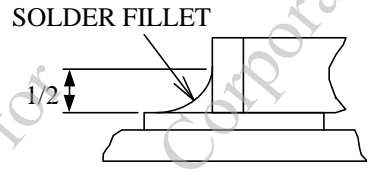
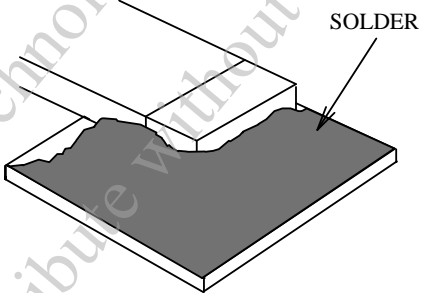
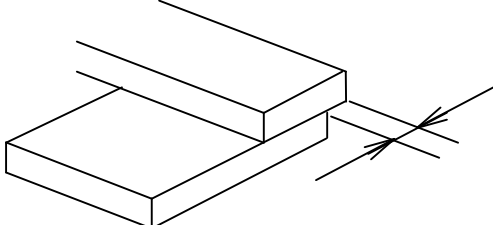
NO.	ITEM	CRITERIA
12	SOLDERING	<p>(1)NO SOLDERING FOUND ON THE SPECIFIED PLACE (2)INSUFFICIENT SOLDER</p> <p>(a)LSI, IC A POOR WETTING OF SOLDER IS BETWEEN LOWER BEND OR "HEEL" OF LEAD AND PAD</p>  <p>(b)CHIP COMPONENT · SOLDER IS LESS THAN 50% OF SIDES AND FRONT FACE WETTING</p>  <p>· SOLDER WETS 3 SIDES OF TERMINAL, BUT LESS THAN 25% OF SIDES AND FRONT SURFACE AREA ARE COVERED</p>  <p>(3)PARTS ALIGNMENT (a)LSI, IC LEAD WIDTH IS MORE THAN 50% BEYOND PAD OUTLINE</p> 

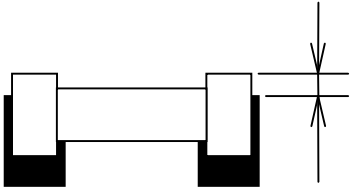
NO.	ITEM	CRITERIA
12	SOLDERING	<p>(b)CHIP COMPONENT COMPONENT IS OFF CENTER, AND MORE THAN 50% OF THE LEADS IS OFF THE PAD OUTLINE</p>  <p>(4)NO UNMELTED SOLDER PASTE MAY BE PRESENT ON THE PCB. (5)NO COLD SOLDER JOINTS, MISSING SOLDER CONNECTIONS, OXIDATION OR ICICLE. (6)NO RESIDUE OR SOLDER BALLS ON PCB. (7)NO SHORT CIRCUITS IN COMPONENTS ON PCB.</p>
13	BACKLIGHT	<p>(1)NO LIGHT (2)FLICKERING AND OTHER ABNORMAL ILLUMINATION (3)SPOTS OR SCRATCHES THAT APPEAR WHEN LIT MUST BE JUDGED USING LCD SPOT, LINES AND CONTAMINATION STANDARDS. (4)BACKLIGHT DOESN'T LIGHT OR COLOR IS WRONG.</p>
14	GENERAL APPEARANCE	<p>(1)NO OXIDATION, CONTAMINATION, CURVES OR, BENDS ON INTERFACE PIN (OLB) OF TCP. (2)NO CRACKS ON INTERFACE PIN (OLB) OF TCP. (3)NO CONTAMINATION, SOLDER RESIDUE OR SOLDER BALLS ON PRODUCT. (4)THE IC ON THE TCP MAY NOT BE DAMAGED, CIRCUITS. (5)THE UPPERMOST EDGE OF THE PROTECTIVE STRIP ON THE INTERFACE PIN MUST BE PRESENT OR LOOK AS IF IT CAUSE THE INTERFACE PIN TO SEVER. (6)THE RESIDUAL ROSIN OR TIN OIL OF SOLDERING (COMPONENT OR CHIP COMPONENT) IS NOT BURNED INTO BROWN OR BLACK COLOR. (7)SEALANT ON TOP OF THE ITO CIRCUIT HAS NOT HARDENED. (8)PIN TYPE MUST MATCH TYPE IN SPECIFICATION SHEET. (9)LCD PIN LOOSE OR MISSING PINS. (10)PRODUCT PACKAGING MUST THE SAME AS SPECIFIED ON PACKAGING SPECIFICATION SHEET. (11)PRODUCT DIMENSION AND STRUCTURE MUST CONFORM TO PRODUCT SPECIFICATION SHEET. (12)THE APPEARANCE OF HEAT SEAL SHOULD NOT ADMIT ANY DIRT AND BREAK.</p>

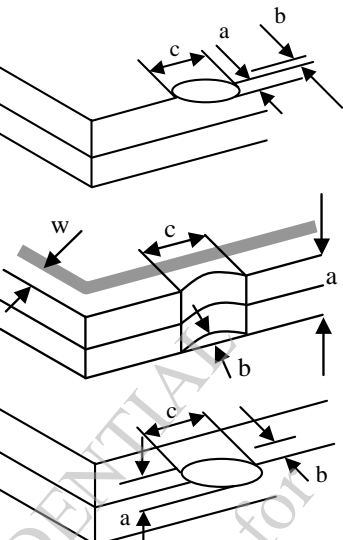
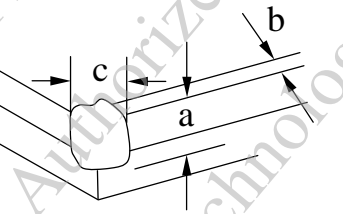
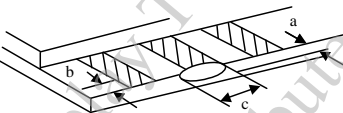
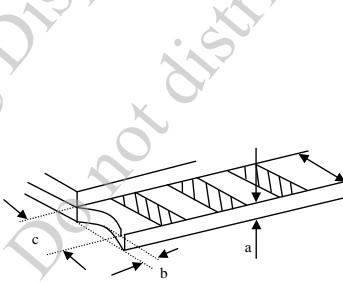
NO.	ITEM	CRITERIA										
15	CRACKED GLASS	THE LCD WITH EXTENSIVE CRACK IS NOT ACCEPTABLE										
		<p>GENERAL GLASS CHIP :</p> 	<table border="1" data-bbox="935 416 1453 483"> <thead> <tr> <th>a</th> <th>b</th> <th>c</th> </tr> </thead> <tbody> <tr> <td>$\leq t/2$</td> <td>< VIEWING AREA</td> <td>$\leq 1/8X$</td> </tr> <tr> <td>$t/2 > , \leq 2t$</td> <td>$\leq W/2$</td> <td>$\leq 1/8X$</td> </tr> </tbody> </table> <p>*W=DISTANCE BETWEEN SEALANT AREA AND LCD PANEL EDGE X = LCD SIDE LENGTH t = GLASS THICKNESS</p>	a	b	c	$\leq t/2$	< VIEWING AREA	$\leq 1/8X$	$t/2 > , \leq 2t$	$\leq W/2$	$\leq 1/8X$
		a	b	c								
		$\leq t/2$	< VIEWING AREA	$\leq 1/8X$								
$t/2 > , \leq 2t$	$\leq W/2$	$\leq 1/8X$										
<p>CORNER PART :</p> 	<table border="1" data-bbox="935 999 1453 1066"> <thead> <tr> <th>a</th> <th>b</th> <th>c</th> </tr> </thead> <tbody> <tr> <td>$\leq t/2$</td> <td>< VIEWING AREA</td> <td>$\leq 1/8X$</td> </tr> <tr> <td>$> t/2 , \leq 2t$</td> <td>$\leq W/2$</td> <td>$\leq 1/8X$</td> </tr> </tbody> </table> <p>*W=DISTANCE BETWEEN SEALANT AREA AND LCD PANEL EDGE X = LCD SIDE LENGTH t = GLASS THICKNESS</p>	a	b	c	$\leq t/2$	< VIEWING AREA	$\leq 1/8X$	$> t/2 , \leq 2t$	$\leq W/2$	$\leq 1/8X$		
a	b	c										
$\leq t/2$	< VIEWING AREA	$\leq 1/8X$										
$> t/2 , \leq 2t$	$\leq W/2$	$\leq 1/8X$										
<p>CHIP ON ELECTRODE PAD</p> 	<table border="1" data-bbox="935 1279 1453 1323"> <thead> <tr> <th>a</th> <th>b</th> <th>c</th> </tr> </thead> <tbody> <tr> <td>$\leq t$</td> <td>$\leq 0.5\text{mm}$</td> <td>$\leq 1/8X$</td> </tr> </tbody> </table> <p>* X=LCD SIDE WIDTH t=GLASS THICKNESS</p>	a	b	c	$\leq t$	$\leq 0.5\text{mm}$	$\leq 1/8X$					
a	b	c										
$\leq t$	$\leq 0.5\text{mm}$	$\leq 1/8X$										
	<table border="1" data-bbox="935 1435 1453 1480"> <thead> <tr> <th>a</th> <th>b</th> <th>c</th> </tr> </thead> <tbody> <tr> <td>$\leq t$</td> <td>$\leq 1/8X$</td> <td>$\leq L$</td> </tr> </tbody> </table> <p>*X=LCD SIDE WIDTH t = GLASS THICKNESS L=ELECTRODE PAD LENGTH ①IF GLASS CHIPPING THE ITO TERMINAL, OVER 2/3 OF THE ITO MUST REMAIN AND BE, INSPECTED ACCORDING TO ELECTRODE TERMINAL SPECIFICATIONS ②IF THE PRODUCT WILL BE HEAT SEALED BY THE CUSTOMER, THE ALIGNMENT MARK MUST NOT BE DAMAGED</p>	a	b	c	$\leq t$	$\leq 1/8X$	$\leq L$					
a	b	c										
$\leq t$	$\leq 1/8X$	$\leq L$										

13.4 RELIABILITY TEST

13.4.1 STANDARD SPECIFICATIONS FOR RELIABILITY OF LCD MODULE

NO.	ITEM	DESCRIPTION
1	HIGH TEMPERATURE OPERATION	THE SAMPLE SHOULD BE ALLOWED TO STAND AT +70°C FOR 240 HRS
2	LOW TEMPERATURE OPERATION	THE SAMPLE SHOULD BE ALLOWED TO STAND AT -20°C FOR 240 HRS
3	HIGH TEMPERATURE STORAGE	THE SAMPLE SHOULD BE ALLOWED TO STAND AT +80°C FOR 240 HRS
4	LOW TEMPERATURE STORAGE	THE SAMPLE SHOULD BE ALLOWED TO STAND AT -30°C FOR 240 HRS
5	HIGH TEMPERATURE /HUMIDITY TEST STORAGE	THE SAMPLE SHOULD BE ALLOWED TO STAND AT 60°C, 90% RH 240 HRS
6	THERMAL SHOCK (NOT OPERATED)	<p>THE SAMPLE SHOULD BE ALLOWED TO STAND THE FOLLOWING 10 CYCLES OF OPERATION :</p> <p>The diagram illustrates a thermal shock cycle. It starts at -30°C for 30 minutes. Then, it ramps up to +70°C in 3 minutes. It stays at +70°C for 30 minutes. Then, it ramps down to -30°C in 3 minutes. Finally, it stays at -30°C for 30 minutes. This entire sequence is labeled as '1 cycle'.</p>
7	ESD (ELECTROSTATIC DISCHARGE) (NOT OPERATED)	AIR DISCHARGE ± 12KV CONTACT DISCHARGE ± 8KV ACCORDING TO IEC-61000-4-2

NOTE (1) : THE TEST SAMPLES HAVE RECOVERY TIME FOR 2 HOURS AT ROOM TEMPERATURE BEFORE THE FUNCTION CHECK. IN THE STANDARD CONDITIONS, THERE IS NO DISPLAY FUNCTION NG ISSUE OCCURRED.

13.5 TESTING CONDITIONS AND INSPECTION CRITERIA

FOR THE FINAL TEST THE TESTING SAMPLE MUST BE STORED AT ROOM TEMPERATURE FOR 24 HOURS, AFTER THE TESTS LISTED IN TABLE 12.5, STANDARD SPECIFICATIONS FOR RELIABILITY HAVE BEEN EXECUTED IN ORDER TO ENSURE STABILITY.

NO.	ITEM	TEST MODEL	INSPECTION CRITERIA
1	CURRENT CONSUMPTION	REFER TO SPECIFICATION	THE CURRENT CONSUMPTION SHOULD CONFORM TO THE PRODUCT SPECIFICATION.
2	CONTRAST	REFER TO SPECIFICATION	AFTER THE TESTS HAVE BEEN EXECUTED, THE CONTRAST MUST BE LARGER THAN HALF OF ITS INITIAL VALUE PRIOR TO THE TESTS.
3	APPEARANCE	VISUAL INSPECTION	DEFECT FREE

13.6 OPERATION

- 13.6.1 DO NOT CONNECT OR DISCONNECT MODULES TO OR FROM THE MAIN SYSTEM WHILE POWER IS BEING SUPPLIED.
- 13.6.2 USE THE MODULE WITHIN SPECIFIED TEMPERATURE ; LOWER TEMPERATURE CAUSES THE RETARDATION OF BLINKING SPEED OF THE DISPLAY ; HIGHER TEMPERATURE MAKES OVERALL DISPLAY DISCOLOR. WHEN THE TEMPERATURE RETURNS TO NORMALITY, THE DISPLAY WILL OPERATE NORMALLY.
- 13.6.3 ADJUST THE LC DRIVING VOLTAGE TO OBTAIN THE OPTIMUM CONTRAST.
- 13.6.4 POWER ON SEQUENCE INPUT SIGNALS SHOULD NOT BE SUPPLIED TO LCD MODULE BEFORE POWER SUPPLY VOLTAGE IS APPLIED AND REACHES THE SPECIFIED VALUE.
IF ABOVE SEQUENCE IS NOT FOLLOWED , CMOS LSIS OF LCD MODULES MAY BE DAMAGED DUE TO LATCH - UP PROBLEM.
- 13.6.5 NOT ALLOWED TO INFLICT ANY EXTERNAL STRESS AND TO CAUSE ANY MECHANICAL INTERFERENCE ON THE BENDING AREA OF FPC DURING THE TAIL BENDING BACKWARDS!
DO NOT STRESS FPC AND IC ON THE MODULE!

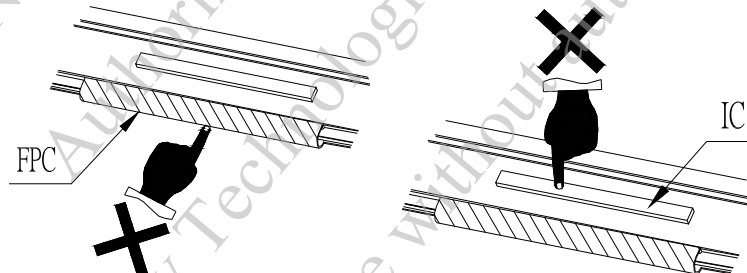

Copyright © Emerging Display Technologies Corporation. All rights reserved.
Do not distribute without permission.

13.7 NOTICE

- 13.7.1 USE A GROUNDED SOLDERING IRON WHEN SOLDERING CONNECTOR I/O TERMINALS . FOR SOLDERING OR REPAIRING, TAKE PRECAUTION AGAINST THE TEMPERATURE OF THE SOLDERING IRON AND THE SOLDERING TIME TO PREVENT PEELING OFF THE THROUGH-HOLE-PAD.
- 13.7.2 DO NOT DISASSEMBLE . EDT SHALL NOT BE HELD RESPONSIBLE IF THE MODULE IS DISASSEMBLED AND UPON THE REASSEMBLY THE MODULE FAILED.
- 13.7.3 DO NOT CHARGE STATIC ELECTRICITY , AS THE CIRCUIT OF THIS MODULE CONTAINS CMOS LSIS. A WORKMAN'S BODY SHOULD ALWAYS BE STATIC-PROTECTED BY USE OF AN ESD STRAP. WORKING CLOTHES FOR SUCH PERSONNEL SHOULD BE OF STATIC-PROTECTED MATERIAL .
- 13.7.4 ALWAYS GROUND THE ELECTRICALLY-POWERED DRIVER BEFORE USING IT TO INSTALL THE LCD MODULE. WHILE CLEANING THE WORK STATION BY VACUUM CLEANER, DO NOT BRING THE SUCKING MOUTH NEAR THE MODULE ; STATIC ELECTRICITY OF THE ELECTRICALLY-POWERED DRIVER OR THE VACUUM CLEANER MAY DESTROY THE MODULE.
- 13.7.5 DON'T GIVE EXTERNAL SHOCK.
- 13.7.6 DON'T APPLY EXCESSIVE FORCE ON THE SURFACE.
- 13.7.7 LIQUID IN LCD IS HAZARDOUS SUBSTANCE. MUST NOT LICK AND SWALLOW.
WHEN THE LIQUID IS ATTACH TO YOUR, SKIN, CLOTH ETC.
WASH IT OUT THOROUGHLY AND IMMEDIATELY.
- 13.7.8 DON'T OPERATE IT ABOVE THE ABSOLUTE MAXIMUM RATING.
- 13.7.9 STORAGE IN A CLEAN ENVIRONMENT, FREE FROM DUST, ACTIVE GAS, AND SOLVENT.
- 13.7.10 STORE WITHOUT ANY PHYSICAL LOAD.
- 13.7.11 REWIRING: NO MORE THAN 3 TIMES.