

EXAMINED BY :	EMERGING DISPLAY TECHNOLOGIES CORPORATION	FILE NO . CAS-0008590
Sam Chou		ISSUE : AUG.08, 2018
APPROVED BY:		TOTAL PAGE : 32
<i>Chris Wu</i>		VERSION : 4

CUSTOMER ACCEPTANCE SPECIFICATIONS

MODEL NO. :

ETML070017DH6

(RoHS)

FOR MESSRS :

CUSTOMER'S APPROVAL

DATE :

BY :

RECORDS OF REVISION	DOC . FIRST ISSUE	JAN.31, 2018
---------------------	-------------------	--------------

DATE	REVISED PAGE NO.	SUMMARY																																																								
APR.17, 2018	4	4.1 LCD MODULE POWER SUPPLY CURRENT : TYP.=(150)→100, MAX.=(200)→150 POWER SUPPLY CURRENT FOR LED DRIVER : TYP.=(450)→400, MAX.=(500)→450																																																								
	12	7. OUTLINE DIMENSIONS MARK Δ : MODIFY TFT C/N & COMPONENT AREA DIMENSION																																																								
APR.25, 2018	4	4.1 LCD MODULE LED LIFE TIME : MIN.=20K→30K NOTE (3) : DEFINITIONS OF FAILURE→DEFINITIONS OF LIFE TIME																																																								
AUG.08, 2018	10	6.1 OPTICAL SPECIFICATIONS <table border="1"> <thead> <tr> <th>ITEM</th> <th>SYMBOL</th> <th>CONDITION</th> <th>MIN.</th> <th>TYP</th> <th>MAX.</th> <th>UNIT</th> <th>REMARK</th> </tr> </thead> <tbody> <tr> <td rowspan="4">VIEWING ANGLE</td> <td>θ_v</td> <td rowspan="4">CR ≥ 10</td> <td>0_v-0°</td> <td>60</td> <td>70</td> <td>—</td> <td rowspan="4">deg. NOTE (2) NOTE (3)</td> </tr> <tr> <td>θ_h</td> <td>60</td> <td>70</td> <td>—</td> </tr> <tr> <td>θ_{v1}</td> <td>40</td> <td>50</td> <td>—</td> </tr> <tr> <td>θ_{v2}</td> <td>50</td> <td>60</td> <td>—</td> </tr> </tbody> </table> <table border="1"> <thead> <tr> <th>ITEM</th> <th>SYMBOL</th> <th>CONDITION</th> <th>MIN.</th> <th>TYP</th> <th>MAX.</th> <th>UNIT</th> <th>REMARK</th> </tr> </thead> <tbody> <tr> <td rowspan="4">VIEWING ANGLE</td> <td>θ_v</td> <td rowspan="4">CR ≥ 10</td> <td>0_v-0°</td> <td>40</td> <td>50</td> <td>—</td> <td rowspan="4">deg. NOTE (2) NOTE (3)</td> </tr> <tr> <td>θ_h</td> <td>50</td> <td>60</td> <td>—</td> </tr> <tr> <td>θ_{v1}</td> <td>60</td> <td>70</td> <td>—</td> </tr> <tr> <td>θ_{v2}</td> <td>60</td> <td>70</td> <td>—</td> </tr> </tbody> </table>	ITEM	SYMBOL	CONDITION	MIN.	TYP	MAX.	UNIT	REMARK	VIEWING ANGLE	θ_v	CR ≥ 10	0 _v -0°	60	70	—	deg. NOTE (2) NOTE (3)	θ_h	60	70	—	θ_{v1}	40	50	—	θ_{v2}	50	60	—	ITEM	SYMBOL	CONDITION	MIN.	TYP	MAX.	UNIT	REMARK	VIEWING ANGLE	θ_v	CR ≥ 10	0 _v -0°	40	50	—	deg. NOTE (2) NOTE (3)	θ_h	50	60	—	θ_{v1}	60	70	—	θ_{v2}	60	70	—
ITEM	SYMBOL	CONDITION	MIN.	TYP	MAX.	UNIT	REMARK																																																			
VIEWING ANGLE	θ_v	CR ≥ 10	0 _v -0°	60	70	—	deg. NOTE (2) NOTE (3)																																																			
	θ_h		60	70	—																																																					
	θ_{v1}		40	50	—																																																					
	θ_{v2}		50	60	—																																																					
ITEM	SYMBOL	CONDITION	MIN.	TYP	MAX.	UNIT	REMARK																																																			
VIEWING ANGLE	θ_v	CR ≥ 10	0 _v -0°	40	50	—	deg. NOTE (2) NOTE (3)																																																			
	θ_h		50	60	—																																																					
	θ_{v1}		60	70	—																																																					
	θ_{v2}		60	70	—																																																					

CONFIDENTIAL
 Authorized for Circulation Only.
 Emerging Display Technologies Corporation
 Do not distribute without authorization.

TABLE OF CONTENTS

NO.	ITEM	PAGE
1.	GENERAL SPECIFICATIONS -----	1
2.	MECHANICAL SPECIFICATIONS -----	1, 2
3.	ABSOLUTE MAXIMUM RATINGS -----	3
4.	ELECTRICAL CHARACTERISTICS -----	4
5.	TIMING CHARACTERISTICS -----	5 ~ 9
6.	OPTICAL CHARACTERISTICS -----	10, 11
7.	OUTLINE DIMENSIONS -----	12
8.	BLOCK DIAGRAM -----	13
9.	DETAIL DRAWING OF DOT MATRIX -----	14
10.	INTERFACE SIGNALS -----	15, 16
11.	POWER SUPPLY -----	17
12.	CAPACITIVE TOUCH PANEL SPECIFICATION -----	18 ~ 21
13.	INSPECTION CRITERION -----	22 ~ 29
14.	RELIABILITY TEST -----	30
15.	CAUTION -----	31, 32

CONFIDENTIAL
Authorized for
Emerging Display Technologies Corporation Only.
Do not distribute without authorization.

1. GENERAL SPECIFICATIONS

1.1 DATA SHEETS FOR CONTROLLER/DRIVER

PLEASE REFER TO :

SITRONIX ST5625CA
SITRONIX ST5091CA

1.2 APPLICATION NOTES FOR CAPACITIVE TOUCH PANEL CONTROLLER/DRIVER

PLEASE REFER TO :

HYCON HY4614

1.3 MATERIAL SAFETY DESCRIPTION

ASSEMBLIES SHALL COMPLY WITH EUROPEAN ROHS REQUIREMENTS, INCLUDING PROHIBITED MATERIALS/COMPONENTS CONTAINING LEAD, MERCURY, CADMIUM, HEXAVALENT CHROMIUM, POLYBROMINATED BIPHENYLS (PBB) AND POLYBROMINATED DIPHENYL ETHERS (PBDE)

2. MECHANICAL SPECIFICATIONS

2.1 LCD MODULE MECHANICAL SPECIFICATIONS

(1) DISPLAY SIZE	-----	7 inch
(2) NUMBER OF DOTS	-----	800W * (RGB) * 480H DOTS
(3) MODULE SIZE	-----	164.9W * 100.3H * 12D(MAX) mm (NOT INCLUDED FPC)
(4) VIEWING AREA	-----	155W * 89.1H mm
(5) ACTIVE AREA	-----	153.60W * 86.64H mm
(6) DOT SIZE	-----	0.064W * 0.1805H mm
(7) PIXEL SIZE	-----	0.192W * 0.1805H mm
(8) LCD TYPE	-----	TFT , TRANSMISSIVE , ANTI-GLARE
(9) COLOR	-----	16.7M
(10) VIEWING DIRECTION	-----	6 O'CLOCK (GRAY LEVEL INVERSION)
(11) BACK LIGHT	-----	LED , COLOR : WHITE
(12) INTERFACE MODE	-----	RGB(24BIT) PARALLEL (SYNC / DE MODE)

MODEL NO.	VERSION	PAGE
ETML070017DH6	4	2

2.2 CAPACITIVE TOUCH PANEL MECHANICAL SPECIFICATIONS

- (1) TOUCH PANEL SIZE ----- 7 inch
- (2) OUTER DIMENSION ----- 163.7W * 100.3H * 1.3D mm
(NOT INCLUDED FPC)
- (3) ACTIVE AREA ----- 155.6W * 91.01H mm
- (4) INPUT TYPE ----- MULTI-TOUCH
- (5) NUMBER OF TOUCH SENSOR ----- 28*16 SENSORS
- (6) INTERFACE MODE ----- I2C
- (7) RESOLUTION ----- 1792*1024

CONFIDENTIAL
Authorized for
Emerging Display Technologies Corporation Only.
Do not distribute without authorization.

3. ABSOLUTE MAXIMUM RATINGS

3.1 TFT MODULE ELECTRICAL ABSOLUTE MAXIMUM RATINGS

ITEM	SYMBOL	MIN.	MAX.	UNIT	REMARK
POWER SUPPLY VOLTAGE	DVDD	-0.5	5	V	—

3.2 CAPACITIVE TOUCH PANEL ELECTRICAL ABSOLUTE MAXIMUM RATINGS

PARAMETER	SYMBOL	MIN.	MAX.	UNIT	REMARK
POWER SUPPLY FOR DRIVER	VDD-VSS	-0.2	4.0	V	
INPUT VOLTAGE	VIN	-0.2	4.0	V	

3.3 ENVIRONMENTAL ABSOLUTE MAXIMUM RATINGS

ITEM	OPERATING		STORAGE		REMARK
	MIN.	MAX.	MIN.	MAX.	
AMBIENT TEMPERATURE	-20°C	70°C	-30°C	80°C	NOTE (1), (2)
HUMIDITY	NOTE (3)		NOTE (3)		WITHOUT CONDENSATION
VIBRATION	—	2.45 m/s ² (0.25 G)	—	11.76 m/s ² (1.2 G)	5~20Hz , 1HR 20~500Hz(20Hz) , 1HR 20~500Hz(500Hz) , 1HR X,Y,Z,TOTAL 3HRS
SHOCK	—	29.4 m/s ² (3 G)	—	490 m/s ² (50 G)	10 ms XYZ DIRECTIONS 1 TIME EACH
CORROSIVE GAS	NOT ACCEPTABLE		NOT ACCEPTABLE		

NOTE (1) : Ta AT -30°C : 48HRS MAX.

80°C : 48HRS MAX.

NOTE (2) : BACKGROUND COLOR CHANGES SLIGHTLY DEPENDING ON AMBIENT
TEMPERATURE THIS PHENOMENON IS REVERSIBLE.

NOTE (3) : Ta ≤ 50°C : 85%RH MAX. (48HRS MAX).

Ta > 50°C : ABSOLUTE HUMIDITY MUST BE LOWER THAN THE HUMIDITY
OF 85%RH AT 50°C(48HRS MAX).

4. ELECTRICAL CHARACTERISTICS

4.1 LCD MODULE

Ta=25°C

ITEM	SYMBOL	CONDITION	MIN.	TYP.	MAX.	UNIT	REMARK
POWER SUPPLY VOLTAGE	DVDD	—	3.15	3.3	3.45	V	
POWER SUPPLY VOLTAGE FOR LED DRIVER	VLED	—	4.7	5	5.3	V	
LOW LEVEL INPUT VOLTAGE	VIL	—	GND	—	0.3*DVDD	V	
HIGH LEVEL INPUT VOLTAGE	VIH	—	0.7*DVDD	—	DVDD	V	
POWER SUPPLY CURRENT	IDVDD	DVDD-GND = 3.3V	—	100	150	mA	NOTE (1)
POWER SUPPLY CURRENT FOR LED DRIVER	IVLED	VLED=5V LED B/L=ON	—	400	450	mA	
LED LIFE TIME	—	ILED=20mA (PER LED)	30K	—	—	hrs	NOTE (2) NOTE (3)

NOTE (1) : TYP. SPECIFICATION : GRAY-LEVEL TEST PATTERN
MAX. SPECIFICATION : BLACK TEST PATTERN.



(a) GRAY-LEVEL PATTERN



(b) BLACK PATTERN

NOTE (2) : CONDITIONS; TA=25 °C, CONTINUOUS LIGHTING

NOTE (3) : DEFINITIONS OF LIFE TIME

LCD LUMINANCE BECOMES HALF OF THE INITIAL VALUE.

4.2 CTP MODULE

Ta=25°C

ITEM	SYMBOL	CONDITION	MIN.	TYP.	MAX.	UNIT
POWER SUPPLY FOR DRIVER	VDD-VSS	—	3.15	3.30	3.45	V
INPUT HIGH LEVEL VOLTAGE	VIH	—	—	0.7*VDD	—	V
INPUT LOW LEVEL VOLTAGE	VIL	—	—	0.3*VDD	—	V
OUTPUT HIGH LEVEL VOLTAGE	VOH	IOH=10mA	VDD-0.3	—	—	V
OUTPUT LOW LEVEL VOLTAGE	VOL	IOH=-10mA	—	—	VSS+0.3	V
POWER SUPPLY CURRENT CONSUMPTION FOR OPERATION	IDD	VDD-VSS=3.30V	—	15	23	mA

5. TIMING CHARACTERISTICS

5.1 FOR LCD MODULE

5.1.1 AC ELECTRICAL CHARACTERISTICS

PARAMETER	SYMBOL	MIN.	TYP.	MAX.	UNIT	CONDITIONS
VDD POWER ON SLEW RATE	T _{POR}	—	—	20	ms	FROM 0V to 90% VDD
RESET PULSE WIDTH	T _{RST}	50	—	—	us	Clkin=50MHz
DCLK CYCLE TIME	T _{cph}	20	—	—	ns	
DCLK PULSE DUTY	T _{cwh}	40	50	60	%	
VSYNC SETUP TIME	T _{vst}	8	—	—	ns	
VSYNC HOLD TIME	T _{vhd}	8	—	—	ns	
HSYNC SETUP TIME	T _{hst}	8	—	—	ns	
HSYNC HOLD TIME	T _{hhd}	8	—	—	ns	
DATA SETUP TIME	T _{dsu}	8	—	—	ns	D[7:0], D1[7:0], D2[7:0] to Clkin
DATA HOLD TIME	T _{dhd}	8	—	—	ns	D[7:0], D1[7:0], D2[7:0] to Clkin
DE SETUP TIME	T _{esu}	8	—	—	ns	
DE HOLD TIME	T _{ehd}	8	—	—	ns	
OUTPUT STABLE TIME	T _{sst}	—	—	6	us	10% TO 90% TARGET VOLTAGE. CL=120pF, R=10Kohm
DCLK FREQUENCY	F _{clk}	—	40	50	MHz	
DCLK CYCLE TIME	T _{clk}	20	25	—	ns	
DCLK PULSE DUTY	T _{cwh}	40	50	60	%	T _{clk}
TIME FROM HSYNC TO SOURCE OUTPUT	T _{hso}	—	64	—	DCLK	

CONFIDENTIAL
Authorized for
Emerging Display Technologies Corporation Only.
Do not distribute without authorization.

INPUT CLOCK AND DATA TIMING DIAGRAM

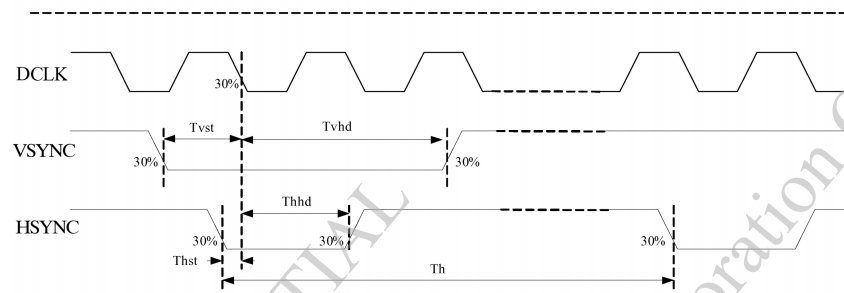
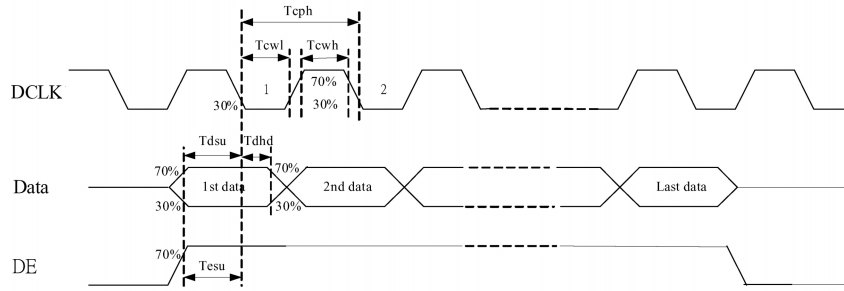

SOURCE OUTPUT TIMING DIAGRAM

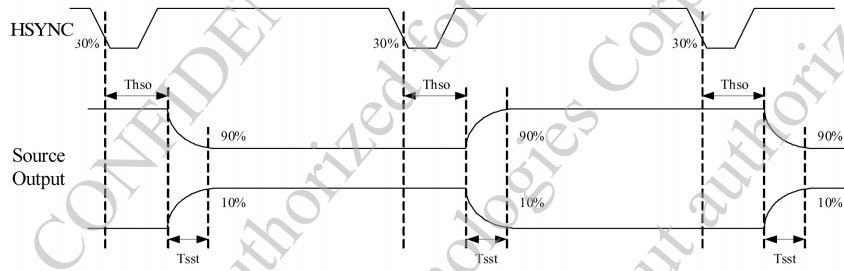

VERTICAL TIMING DIAGRAM SYNC (TCON + SOURCE MODE)

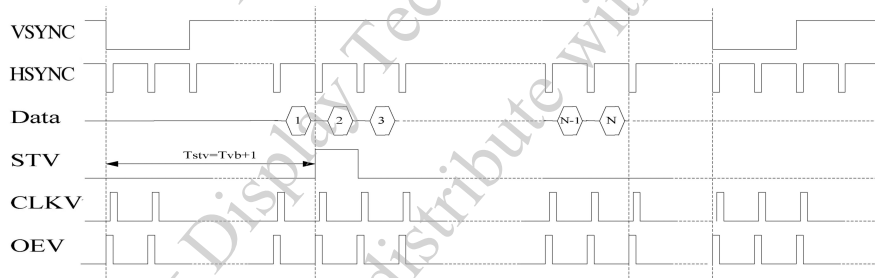

VERTICAL TIMING DIAGRAM DE (TCON + SOURCE MODE)

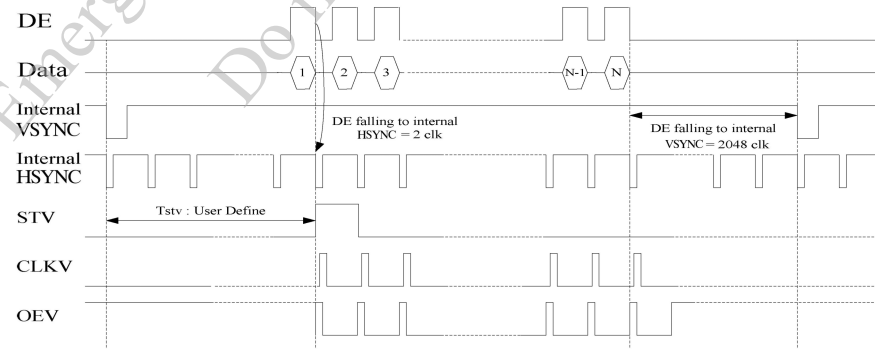

5.1.2 TIMING CHARACTERISTICS

PARAMETER	SYMBOL	MIN.	TYP.	MAX.	UNIT
HORIZONTAL DISPLAY AREA	thd		800		DCLK
DCLK FREQUENCY	fclk	—	30	50	MHz
ONE HORIZONTAL LINE	th	889	928	1143	DCLK
HSYNC PULSE WIDTH	thpw	1	48	255	DCLK
HSYNC BACK PORCH (BLANKING)	thb		88		DCLK
HSYNC FRONT PORCH	thfb	1	40	255	DCLK
DE MODE BLANKING	th-thd	85	128	512	DCLK
VERTICAL DISPLAY AREA	tvd		480		H
VSYNC PERIOD TIME	tv	513	525	767	H
VSYNC PULSE WIDTH	tvpw	3	3	255	H
VSYNC BACK PORCH (BLANKING)	tvb		32		H
VSYNC FRONT PORCH	tvfb	1	13	255	H
DE MODE BLANKING	tv-tvd	4	45	255	H

VERTICAL INPUT TIMING

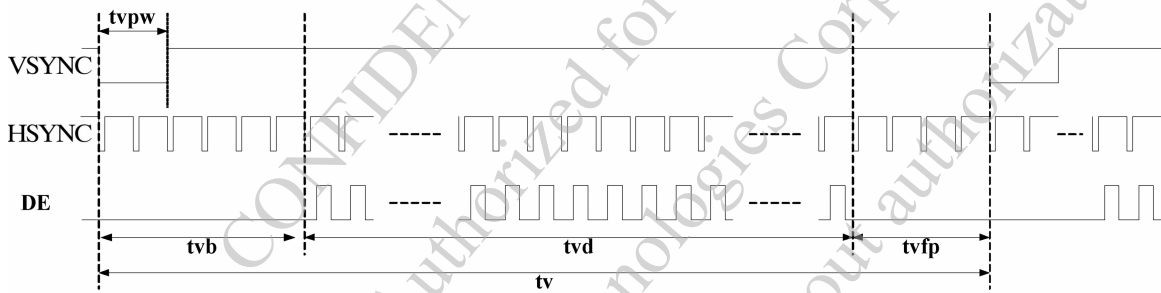

HORIZONTAL INPUT TIMING

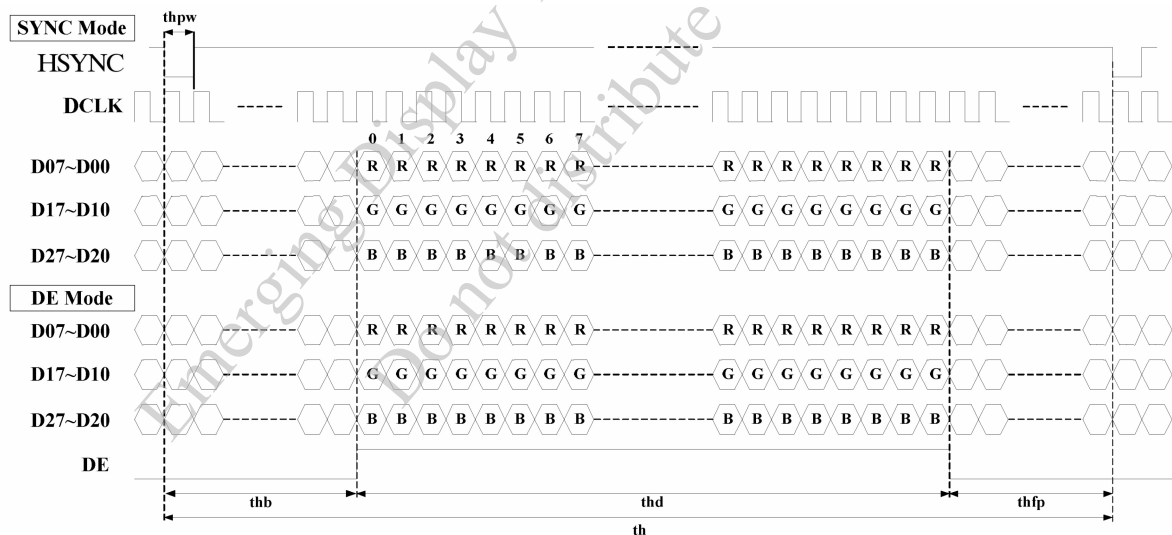

5.2 FOR CTP MODULE

5.2.1 I2C INTERFACE TIMING CHARACTERISTICS

ITEM	MIN.	TYP.	MAX.	UNIT
SCL FREQUENCY	0	—	400	KHz
BUS FREE TIME BETWEEN A STOP AND START CONDITION	1.3	—	—	us
HOLD TIME (REPEATED) START CONDITION	0.6	—	—	us
DATA SETUP TIME	100	—	—	ns
SETUP TIME FOR A REPEATED START CONDITION	0.6	—	—	us
SETUP TIME FOR STOP CONDITION	0.6	—	—	us

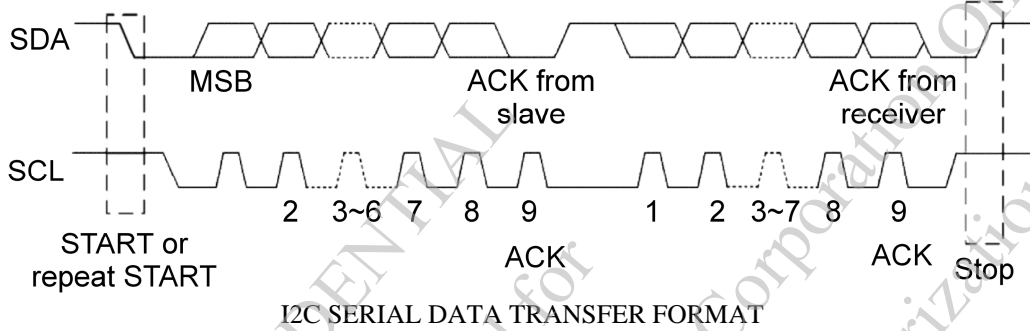

CONFIDENTIAL
Authorized for
Emerging Display Technologies Corporation Only.
Do not distribute without authorization.

5.2.2 POWER SEQUENCE

ITEM	SYMBOL	MIN.	TYP.	MAX.	UNIT
RISE TIME FROM 0.1VDD TO 0.9VDD	Tris	—	—	5	ms
TIME OF RESETTING TO BE LOW BEFORE POWERING ON	Trtp	100	—	—	us
TIME OF STARTING TO REPORT POINT AFTER POWERING ON	Tpon	200	—	—	ms
RESET TIME AFTER VDD POWERING ON	Tvdr	1	—	—	ms
TIME OF STARTING TO REPORT POINT AFTER RESETTING	Trsi	200	—	—	ms
RESET TIME	Trst	2	—	—	ms

POWER RISE TIMING

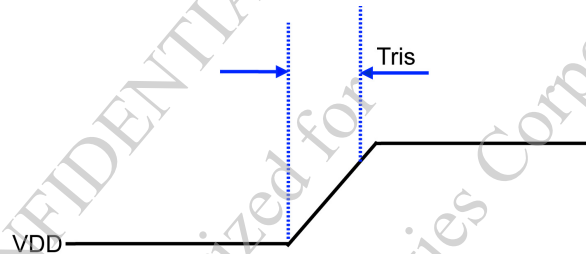

POWER ON / OFF TIMING

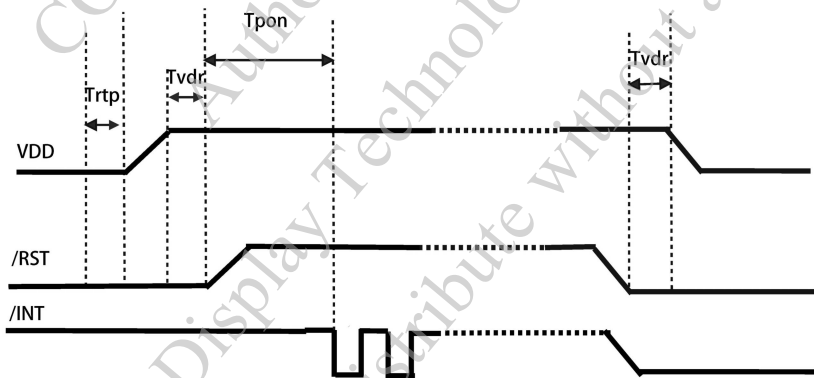

RESET SEQUENCE

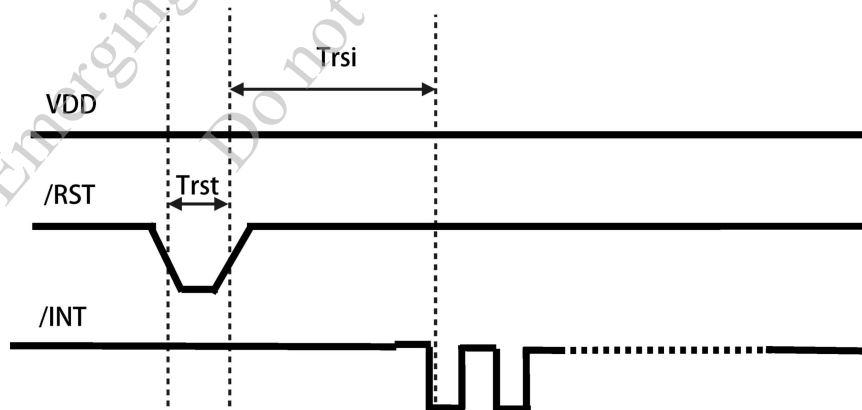

6. OPTICAL CHARACTERISTICS (NOTE 1)

6.1 OPTICAL SPECIFICATIONS

Ta = 25 ± 2 °C

ITEM	SYMBOL	CONDITION	MIN.	TYP.	MAX.	UNIT	REMARK	
VIEWING ANGLE	θ_{y+}	CR ≥ 10	$\theta_x=0^\circ$	40	50	—	deg.	NOTE (2) NOTE (3)
	θ_{y-}			50	60	—		
	θ_{x+}		$\theta_y=0^\circ$	60	70	—		
	θ_{x-}			60	70	—		
CONTRAST RATIO	CR	$\theta_x=0^\circ, \theta_y=0^\circ$	400	500	—	—	NOTE (3)	
RESPONSE TIME	Tr + Tf	$\theta_x=0^\circ, \theta_y=0^\circ$	—	25	35	msec	NOTE (4)	
THE BRIGHTNESS OF MODULE	B		250	290	—	cd/m ²		
COLOR OF CIE COORDINATE	WHITE	Wx	$\theta_x=0^\circ, \theta_y=0^\circ$ DVDD-GND=3.3V VLED-VLSS=5V	0.26	0.31	0.36	—	NOTE (5) NOTE (6)
		Wy		0.29	0.34	0.39		
	RED	Rx		0.57	0.62	0.67	—	
		Ry		0.32	0.37	0.42		
	GREEN	Gx		0.30	0.35	0.40	—	
		Gy		0.54	0.59	0.64		
	BLUE	Bx		0.11	0.16	0.21	—	
		By		0.07	0.12	0.17		
THE UNIFORMITY OF MODULE	—		65	70	—	%		

NOTE (1) : TEST EQUIPMENT SETUP :

AFTER STABILIZING AND LEAVING THE PANEL ALONE AT A GIVEN TEMPERATURE FOR 30 MINUTES. MEASUREMENT SHOULD BE EXECUTED IN A STABLE, WINDLESS, AND DARK ROOM. OPTICAL SPECIFICATIONS ARE MEASURED BY TOPCON BM-7 (FAST) WITH A VIEWING ANGLE OF 1° AT A DISTANCE OF 50cm AND NORMAL DIRECTION.

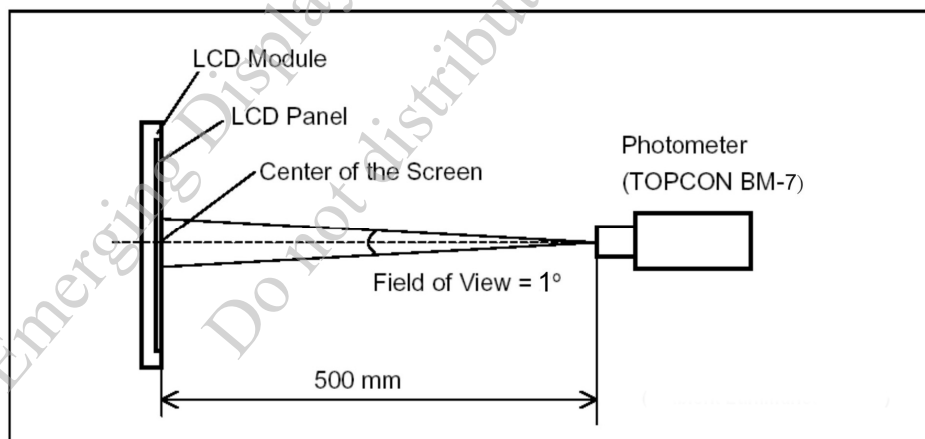

NOTE (2) : DEFINITION OF VIEWING ANGLE :

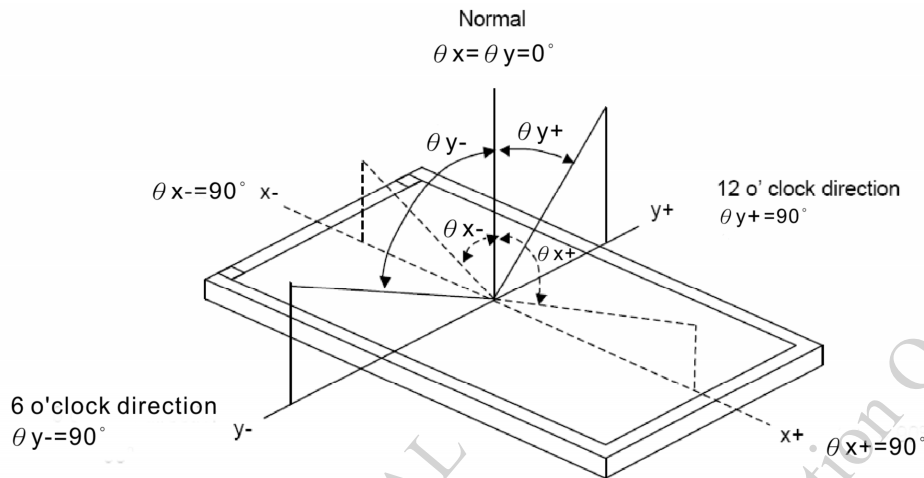

NOTE (3) : DEFINITION OF CONTRAST RATIO :

$$\text{CONTRAST RATIO(CR)} = \frac{\text{BRIGHTNESS MEASURED WHEN LCD IS AT "WHITE STATE"}}{\text{BRIGHTNESS MEASURED WHEN LCD IS AT "BLACK STATE"}}$$

NOTE (4) : DEFINITION OF RESPONSE TIME : T_R AND T_F

THE FIGURE BELOW IS THE OUTPUT SIGNAL OF THE PHOTO DETECTOR.

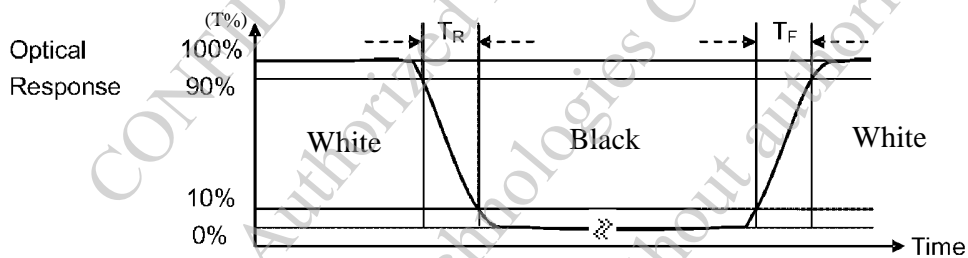

NOTE (5) : THE 100% TRANSMISSION IS DEFINED AS THE TRANSMISSION OF LCD PANEL WHEN ALL THE INPUT TERMINALS OF MODULE ARE ELECTRICALLY OPENED.

NOTE (6) : (a) BRIGHTNESS MEASURED WHEN LCD IS AT "WHITE STATE"
(b) THE TEST METHOD OF BRIGHTNESS AND UNIFORMITY

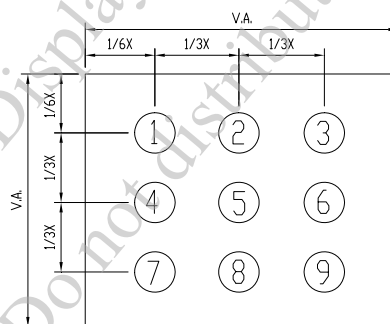

UNIT : mm

(c) THE CALCULATING METHOD OF UNIFORMITY

$$\text{UNIFORMITY} = \left[1 - \frac{\text{MAXIMUM BRIGHTNESS} - \text{MINIMUM BRIGHTNESS}}{\text{AVERAGE BRIGHTNESS}} \right] \times 100\%$$

7. OUTLINE DIMENSIONS

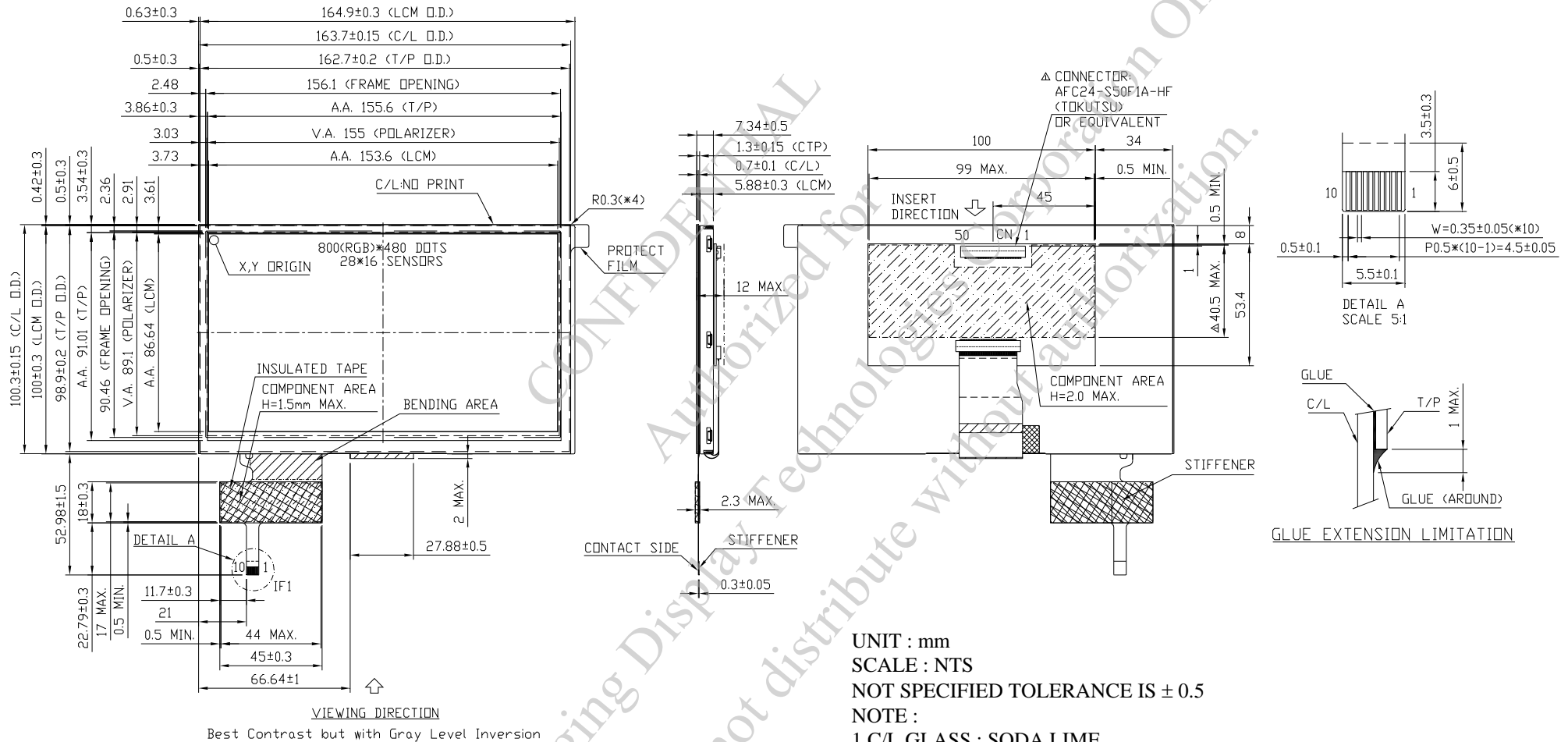

UNIT : mm
SCALE : NTS
NOT SPECIFIED TOLERANCE IS ± 0.5
NOTE :
1.C/L GLASS : SODA LIME
CTP RECOMMEND MATCH CONNECTOR KYOCERA : 04 6240 010 SERIES
2.MARK Δ MODIFY (NUMBER NOTE MODIFY VERSION)

8. BLOCK DIAGRAM

8.1 TFT

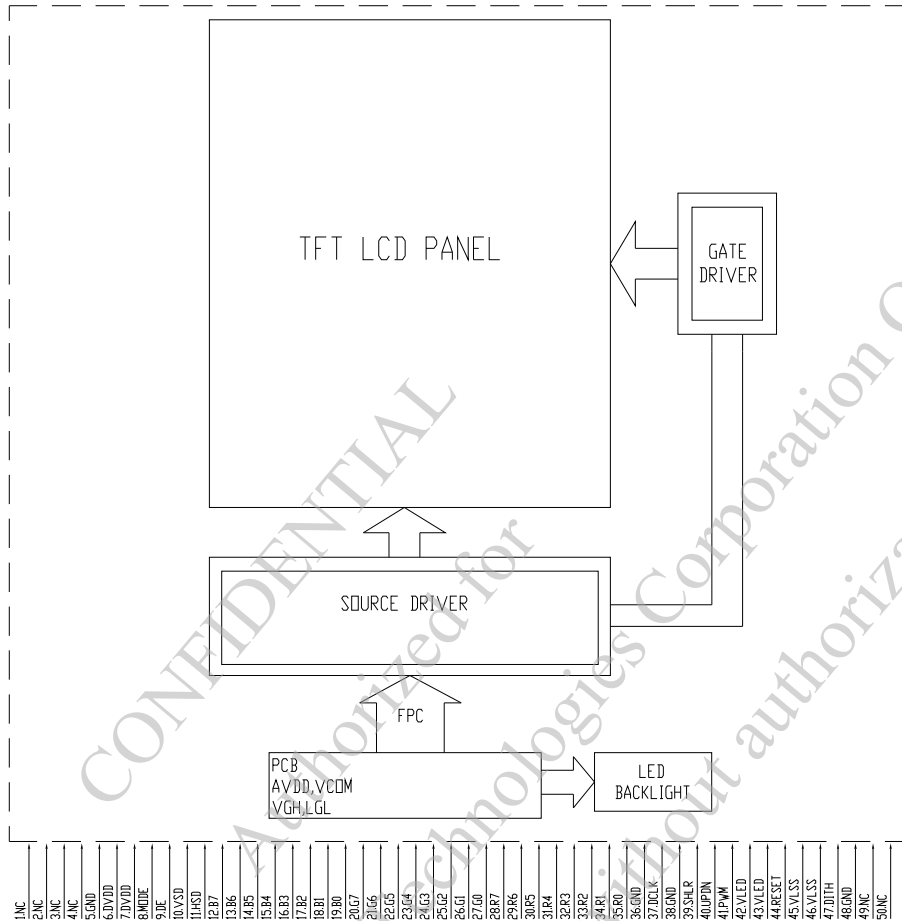

8.2 CTP

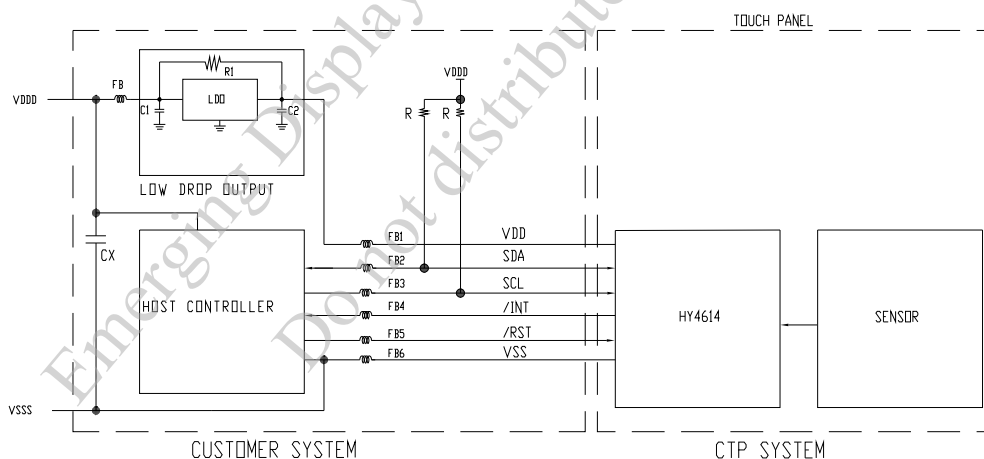

NOTE (1) : THE STANDARD IIC COMMUNICATION INTERFACE, SUPREME SCL CLOCK IS 400 KHZ, SLAVE ADDRESS CAN BE SET UP, SUPPORTS VDD LEVEL POWER, NEEDS PULL HIGH RESISTANCE AND WE RECOMMEND THE PULL HIGH RESISTANCE IS 2.0K OHM.

NOTE (2) : POWER SUPPLY SHALL BE CLEAN AND NOISE FREE. ADDITIONAL FILTERING OR A SEPARATE LDO (LOW DROP OUT) REGULATOR CAN BE REQUIRED. C1 AND C2 CAPACITORS RECOMMENDATION : 4.7 μ F OR 10 μ F
LDO OUTPUT : MIN. 3.15V. VDD MIN. 3.15V + DROPOUT VOLTAGE OF LDO

9. DETAIL DRAWING OF DOT MATRIX

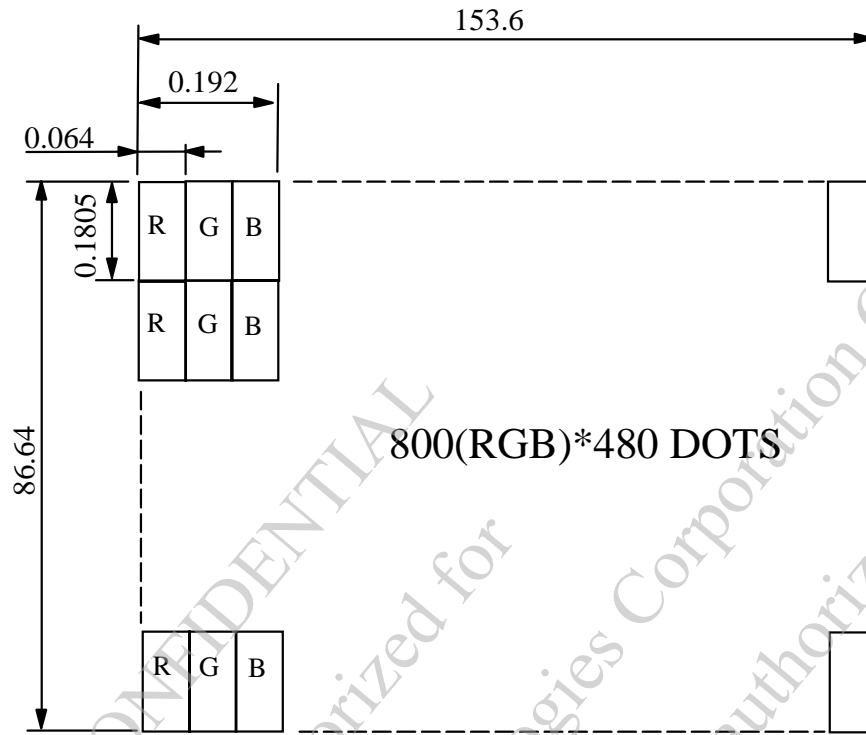

UNIT : mm
SCALE : NTS
NOT SPECIFIED TOLERANCE IS ± 0.1
DOTS MATRIX TOLERANCE IS ± 0.01

CONFIDENTIAL
Authorized for Emerging Display Technologies Corporation Only.
Do not distribute without authorization.

10. INTERFACE SIGNALS

10.1 TFT

PIN NO.	SYMBOL	I/O/P	FUNCTION
1	NC	P	NO CONNECTION
2	NC	P	NO CONNECTION
3	NC	P	NO CONNECTION
4	NC	P	NO CONNECTION
5	GND	P	POWER GROUND
6	DVDD	P	POWER SUPPLY
7	DVDD	P	POWER SUPPLY
8	MODE	I	DE/SYNC MODE SELECT. NORMALLY PULL HIGH H: DE MODE. L: HSD/VSD MODE
9	DE	I	DATA INPUT ENABLE
10	VSD	I	VERTICAL SYNC INPUT. NEGATIVE POLARITY
11	HSD	I	HORIZONTAL SYNC INPUT. NEGATIVE POLARITY
12	B7	I	BLUE DATA(MSB)
13	B6	I	BLUE DATA
14	B5	I	BLUE DATA
15	B4	I	BLUE DATA
16	B3	I	BLUE DATA
17	B2	I	BLUE DATA
18	B1	I	BLUE DATA
19	B0	I	BLUE DATA(LSB)
20	G7	I	GREEN DATA(MSB)
21	G6	I	GREEN DATA
22	G5	I	GREEN DATA
23	G4	I	GREEN DATA
24	G3	I	GREEN DATA
25	G2	I	GREEN DATA
26	G1	I	GREEN DATA
27	G0	I	GREEN DATA(LSB)
28	R7	I	RED DATA(MSB)
29	R6	I	RED DATA
30	R5	I	RED DATA
31	R4	I	RED DATA
32	R3	I	RED DATA
33	R2	I	RED DATA
34	R1	I	RED DATA
35	R0	I	RED DATA(LSB)
36	GND	P	POWER GROUND
37	DCLK	I	CLOCK INPUT
38	GND	P	POWER GROUND
39	SHLR	I	LEFT OR RIGHT DISPLAY CONTROL
40	UPDN	I	UP / DOWN DISPLAY CONTROL
41	PWM	P	ADJUST FOR LED BRIGHTNESS
42	VLED	P	POWER SUPPLY VOLTAGE FOR LED BACKLIGHT

PIN NO.	SYMBOL	I/O/P	FUNCTION
43	VLED	P	POWER SUPPLY VOLTAGE FOR LED BACKLIGHT
44	RESET	I	GLOBAL RESET PIN. ACTIVE LOW TO ENTER RESET STATE. SUGGEST TO CONNECTING WITH AN RC RESET CIRCUIT FOR STABILITY. NORMALLY PULL HIGH. (R=10KΩ, C=1μF)
45	VLSS	P	LED BACKLIGHT GROUND
46	VLSS	P	LED BACKLIGHT GROUND
47	DITH	I	DITHERING SETTING DITH=" H " 6BIT RESOLUTION (LAST 2 BIT OF INPUT DATA TRUNCATED) DITH=" L " 8BIT RESOLUTION (DEFAULT SETTING)
48	GND	P	POWER GROUND
49	NC	P	NO CONNECTION
50	NC	P	NO CONNECTION

NOTE (1) : SHLR : LEFT OR RIGHT SETTING

UPDN : UP OR DOWN SETTING

SHLR	UPDN	DATA SHIFTING
DVDD	GND	LEFT TO RIGHT, UP TO DOWN (DEFAULT)
GND	GND	RIGHT TO LEFT, UP TO DOWN
DVDD	DVDD	LEFT TO RIGHT, DOWN TO UP
GND	DVDD	RIGHT TO LEFT, DOWN TO UP

NOTE (2) : DEFINITION OF SCANNING DIRECTION.

REFER TO THE FIGURE AS BELOW :

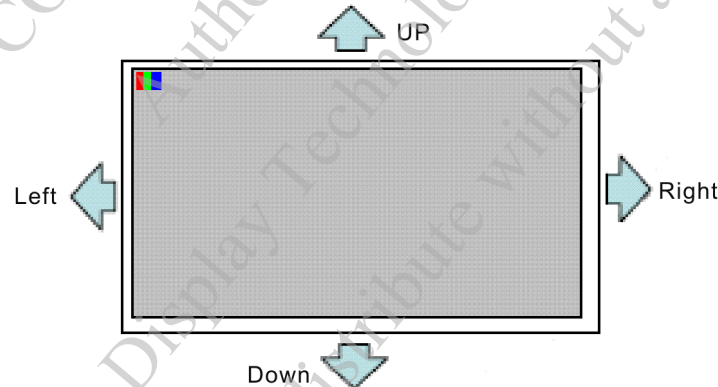

10.2 CTP

PIN NO.	SYMBOL	FUNCTION
1	VSS	GROUND
2	VDD	POWER SUPPLY VOLTAGE
3	SCL	I2C CLOCK INPUT
4	NC	NON CONNECTION
5	SDA	I2C DATA INPUT AND OUTPUT
6	NC	NON CONNECTION
7	/RST	EXTERNAL RESET, LOW IS ACTIVE
8	NC	NON CONNECTION
9	/INT	EXTERNAL INTERRUPT TO THE HOST
10	VSS	GROUND

11. POWER SUPPLY

11.1 POWER SUPPLY FOR LCM

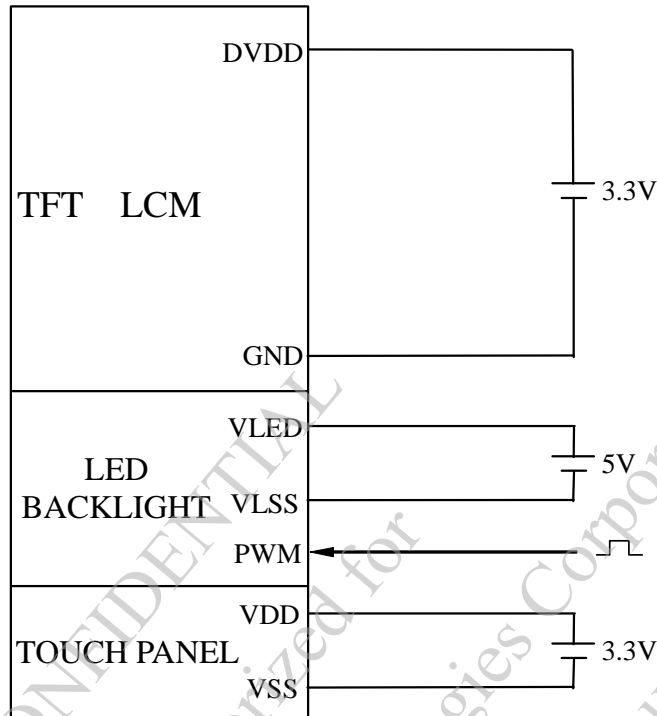

NOTE (1) : ADJUST THE PWM SIGNAL IN ORDER TO CONTROL LED BACKLIGHT'S BRIGHTNESS. THE HIGHER THE DUTY CYCLE, THE HIGHER THE BRIGHTNESS

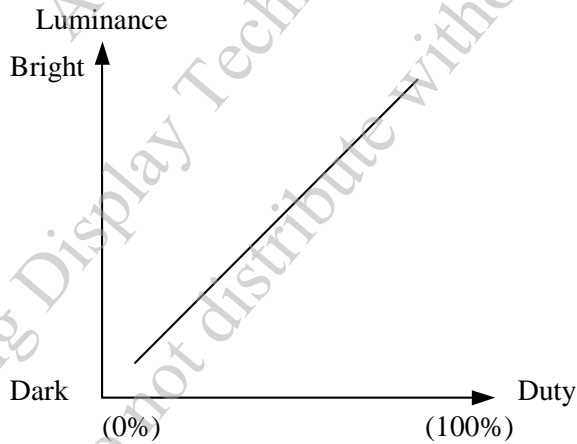

NOTE (2) : PWM SIGNAL OPERATION FREQUENCY IS 100~10KHz.

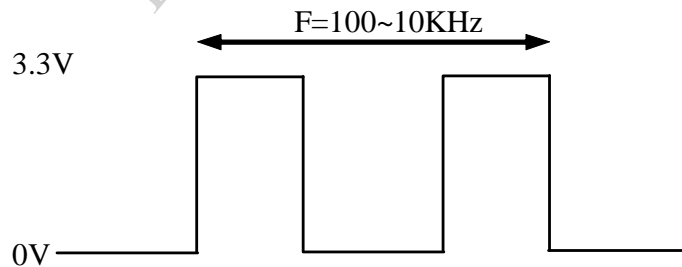

12. CAPACITIVE TOUCH PANEL SPECIFICATION

12.1 OPTICAL CHARACTERISTICS

ITEM	CONDITION	MIN.	TYP.	MAX.	UNIT
TRANSPARENCY NOTE (1)	T _a = 25°C λ = 550nm	85	—	—	%

NOTE (1) : OPTICAL MEASUREMENT SHOULD BE EXECUTED AFTER PANEL IS SECURED.
MEASUREMENT PROCESS SHOULD BE EXECUTED IN A STABLE, WINDLESS, AND DARK ROOM.
OPTICAL SPECIFICATIONS SHOULD BE MEASURED BY SPECTROPHOTOMETER.

12.2 HARDNESS

ITEM	DESCRIPTION
SURFACE HARDNESS	7H (min)

12.3 DURABILITY

USING STEEL BALL AND FALLING ON TOUCH PANEL SURFACE, FROM THE HEIGHT MUST PASS BELOW CONDITIONS :

ITEM	CONDITION	INSPECTION METHOD	DESCRIPTION
STEEL BALL DROP TEST	WEIGHT : 67g HEIGHT OF FALL : 30 cm	VISUAL INSPECTION	SIGN OF FRACTURE OR DAMAGE IS NOT ACCEPTABLE 3 TIMES/ 1 POINTS, 25°C(CENTER TEST)

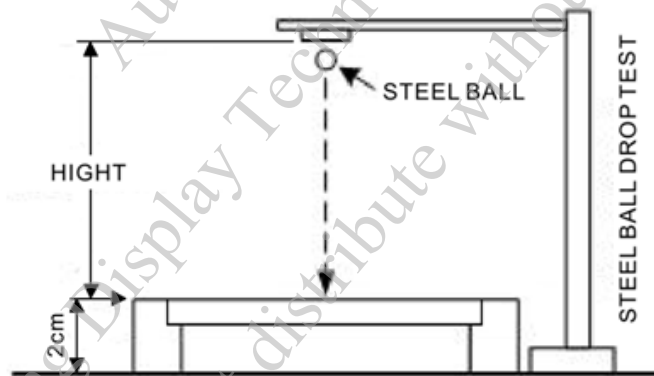

12.4 PROTOCOL

12.4.1 I2C READ

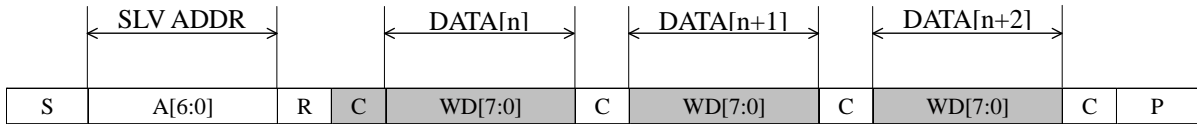

CHARACTER	DESCRIPTION
S	I2C START OR I2C RESTART
A[6:0]	SLAVE ADDRESS, THE VALUE CAN BE CUSTOMIZED
R	OPERATOR BYTE, SHOULD BE 1'b1, STANDS FOR READ
C	ACK SIGNAL
P	STOP SIGNAL (STOP SIGNAL IS OPTIONAL, RESTART SIGNAL IS ALSO OK FOR NEXT PACKET)

SLAVE ADDRESS=0x38

12.4.2 INTERRUPT SIGNAL FOR CTPM TO HOST

AS FOR STANDARD CTPM, HOST NEED TO USE BOTH INTERRUPT CONTROL SIGNAL AND SERIAL DATA INTERFACE TO GET THE TOUCH DATA. HERE IS THE TIMING TO GET TOUCH DATA

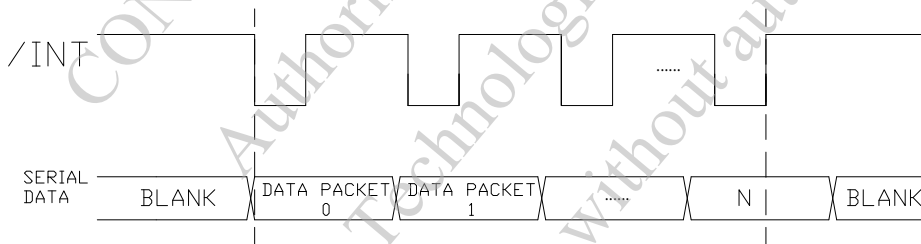

12.4.3 READ TOUCH DATA PACKET

WE DEFINED A CTPM PERIOD AS EACH CAPACITANCE DATA GATHERING AND DATA PROCESS, IN EACH CTPM, IF THERE IS A TOUCH DETECTS, THERE WILL WE A FAME OF TOUCH DATA. HOST CAN GET THE SPECIFIED FORMAT TOUCH DATA BY SERIAL DATA INTERFACE.

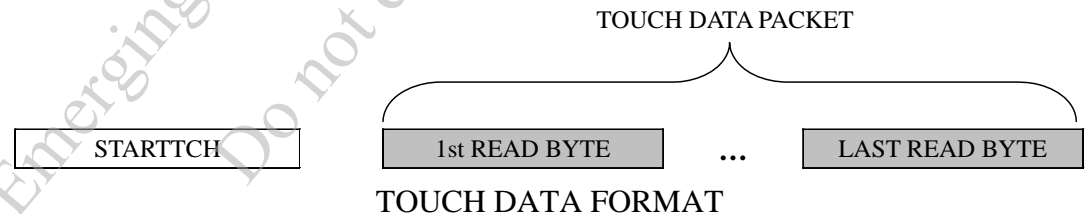

TOUCH DATA READ PROTOCOL

IN THIS MODE THE CTP IS FULLY FUNCTIONAL AS A TOUCH SCREEN CONTROLLER. READ AND WRITE ACCESS ADDRESS IS JUST LOGICAL ADDRESS WHICH IS NOT ENFORCED BY HARDWARE OR FIRMWARE. HERE IS THE OPERATING MODE REGISTER MAP.

ADDRESS	NAME	BIT7	BIT6	BIT5	BIT4	BIT3	BIT2	BIT1	BIT0	HOST ACCESS	
02h	TD_STATUS					NUMBER OF TOUCH POINTS[3:0]				R	
03h	TOUCH1_XH	1 st EVENT FLAG				1 st TOUCH X POSITION[11:8]				R	
04h	TOUCH1_XL	1 st TOUCH X POSITION[7:0]									R
05h	TOUCH1_YH	1 st TOUCH ID[3:0]				1 st TOUCH Y POSITION[11:8]				R	
06h	TOUCH1_YL	1 st TOUCH Y POSITION[7:0]									R
07h											
08h											
09h	TOUCH2_XH	2 nd EVENT FLAG				2 nd TOUCH X POSITION[11:8]				R	
0Ah	TOUCH2_XL	2 nd TOUCH X POSITION[7:0]									R
0Bh	TOUCH2_YH	2 nd TOUCH ID[3:0]				2 nd TOUCH Y POSITION[11:8]				R	
0Ch	TOUCH2_YL	2 nd TOUCH Y POSITION[7:0]									R
0Dh											R
0Eh											R
0Fh	TOUCH3_XH	3 rd EVENT FLAG				3 rd TOUCH X POSITION[11:8]				R	
10h	TOUCH3_XL	3 rd TOUCH X POSITION[7:0]									R
11h	TOUCH3_YH	3 rd TOUCH ID[3:0]				3 rd TOUCH Y POSITION[11:8]				R	
12h	TOUCH3_YL	3 rd TOUCH Y POSITION[7:0]									R
13h											R
14h											R
15h	TOUCH4_XH	4 th EVENT FLAG				4 th TOUCH X POSITION[11:8]				R	
16h	TOUCH4_XL	4 th TOUCH X POSITION[7:0]									R
17h	TOUCH4_YH	4 th TOUCH ID[3:0]				4 th TOUCH Y POSITION[11:8]				R	
18h	TOUCH4_YL	4 th TOUCH Y POSITION[7:0]									R
19h											R
1Ah											R
1Bh	TOUCH5_XH	5 th EVENT FLAG				5 th TOUCH X POSITION[11:8]				R	
1Ch	TOUCH5_XL	5 th TOUCH X POSITION[7:0]									R
1Dh	TOUCH5_YH	5 th TOUCH ID[3:0]				5 th TOUCH Y POSITION[11:8]				R	
1Eh	TOUCH5_YL	5 th TOUCH Y POSITION[7:0]									R
1Fh											R
20h											R
A6h	ID_G_FIRMID	FIRMWARE ID								R	

TD_STATUS

THIS REGISTER IS THE TOUCH DATA STATUS REGISTER.

ADDRESS	BIT ADDRESS	REGISTER NAME	DESCRIPTION
02h	3:0	NUMBER OF TOUCH POINTS [3:0]	HOW MANY POINTS DETECTED. 1-5 IS VALID.
	7:4	NONE	NONE

TOUCH_n_XH (n:1-5)

THIS REGISTER DESCRIBES MSB OF THE X COORDINATE OF THE NTH TOUCH POINT AND THE CORRESPONDING EVENT FLAG.

ADDRESS	BIT ADDRESS	REGISTER NAME	DESCRIPTION
03h ~ 1Bh	7:6	EVENT FLAG	00b: PUT DOWN 01b: PUT UP 10b: CONTACT 11b: RESERVED
	5:4	NONE	RESERVED
	3:0	TOUCH X POSITION [11:8]	MSB OF TOUCH X POSITION IN PIXELS

TOUCH_n_XL (n:1-5)

THIS REGISTER DESCRIBES LSB OF THE X COORDINATE OF THE NTH TOUCH POINT.

ADDRESS	BIT ADDRESS	REGISTER NAME	DESCRIPTION
04h ~ 1Ch	7:0	TOUCH X POSITION [7:0]	LSB OF THE TOUCH X POSITION IN PIXELS

TOUCH_n_YH (n:1-5)

THIS REGISTER DESCRIBES MSB OF THE Y COORDINATE OF THE NTH TOUCH POINT AND CORRESPONDING TOUCH ID.

ADDRESS	BIT ADDRESS	REGISTER NAME	DESCRIPTION
05h ~ 1Dh	7:4	TOUCH ID [3:0]	TOUCH ID OF TOUCH POINT
	3:0	TOUCH X POSITION [11:8]	MSB OF TOUCH Y POSITION IN PIXELS

TOUCH_n_YL (n:1-5)

THIS REGISTER DESCRIBES LSB OF THE Y COORDINATE OF THE NTH TOUCH POINT.

ADDRESS	BIT ADDRESS	REGISTER NAME	DESCRIPTION
06h ~ 1Eh	7:0	TOUCH X POSITION [7:0]	LSB OF THE TOUCH Y POSITION IN PIXELS

ID_G_FIRMWARE_ID

THIS REGISTER DESCRIBES THE FIRMWARE ID OF THE APPLICATION

ADDRESS	BIT ADDRESS	REGISTER NAME	DESCRIPTION
A6h	7:0	ID_G_FIRMWARE_ID	FIRMWARE VERSION

13. INSPECTION CRITERION

13.1 APPLICATION

THIS INSPECTION STANDARD IS TO BE APPLIED TO THE LCD MODULE DELIVERED FROM EMERGING DISPLAY TECHNOLOGIES CORP.(E.D.T) TO CUSTOMERS

13.2 INSPECTION CONDITIONS

13.2.1 (1)OBSERVATION DISTANCE : 45±5cm

(2)VIEWING ANGLE : ±45°

±45° (FOR SECTION WITHIN VIEWING AREA), REFER TO FIG.A
90° (FOR SECTION OUTSIDE OF VIEWING AREA), REF TO FIG.B
PERPENDICULAR TO MODULE SURFACE

VIEWING ANGLE SHOULD BE SMALLER THAN 45°

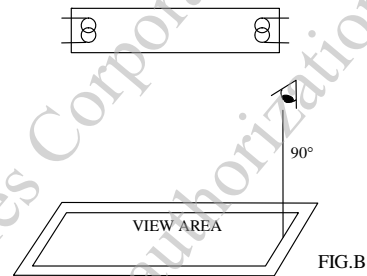
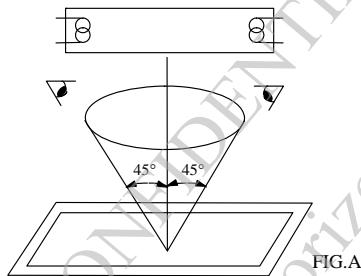

THE INSPECTION CRITERIA IS ACCORDING TO LINE OF SIGHT. INSPECTION SHALL BE MADE WITHIN THE HALF SECTION OF THE VIEWING CONE GENERATED BY LINE SEGMENT OF 45° WITH RESPECTS TO THE VERTICAL AXIS FROM CENTER VERTEX OF LCD, THE FLUORESCENT LAMP AND THE CONE AXIS MUST BE PERPENDICULAR TO THE LCD SURFACE.

IF THE DEFECTS ARE OUTSIDE OF VIEWING AREA, IT SHALL BE INSPECTED BY 90° WITH RESPECTS TO THE VERTICAL AXIS FROM EDGE OF VIEWING AREA.

13.2.2 ENVIRONMENT CONDITIONS :

AMBIENT TEMPERATURE		25±5°C
AMBIENT HUMIDITY		65 ± 20%RH
AMBIENT ILLUMINATION	COSMETIC INSPECTION	600~800 lux
	FUNCTIONAL INSPECTION	300~500 lux
INSPECTION TIME		15 secs

13.2.3 INSPECTION LOT

QUANTITY PER DELIVERY LOT FOR EACH MODEL

13.2.4 A SAMPLING INSPECTION SHALL BE MADE ACCORDING TO THE FOLLOWING PROVISIONS TO JUDGE THE ACCEPTABILITY

(a)APPLICABLE STANDARD :















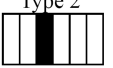

MIL-STD-105E LEVEL II
NORMAL INSPECTION, SINGLE SAMPLING

(b)AQL : MAJOR DEFECT : AQL 0.65
MINOR DEFECT : AQL 1.0

13.3 DEFECTS CLASSIFICATION

TYPE OF DEFECT	INSPECTION ITEM	DEFECT FEATURE	AQL
MAJOR DEFECT	1.DISPLAY ON	<ul style="list-style-type: none"> • DEFECT TO MISS SPECIFIED DISPLAY FUNCTION, FOR ALL AND SPECIFIED DOTS EX: DISCONNECTION, SHORT CIRCUIT ETC 	0.65
	2.CTP FUNCTION	<ul style="list-style-type: none"> • NO FUNCTION • BROKEN LINE • FALSE TOUCH 	
	3.BACKLIGHT	<ul style="list-style-type: none"> • NO LIGHT • FLICKERING AND OTHER ABNORMAL ILLUMINATION 	
	4.DIMENSIONS	<ul style="list-style-type: none"> • SUBJECT TO INDIVIDUAL ACCEPTANCE SPECIFICATIONS 	
MINOR DEFECT	1.DISPLAY ZONE (VIEWING AREA)	<ul style="list-style-type: none"> • BLACK/WHITE SPOT / CIRCULAR TYPE • BUBBLES ON POLARIZER • NEWTON RING • BLACK/WHITE LINE / LINEAR TYPE • SCRATCH • CONTAMINATION • UNEVEN COLOR SPREAD 	1.0
	2.BEZEL ZONE	<ul style="list-style-type: none"> • STAINS • SCRATCHES • FOREIGN MATTER 	
	3.SOLDERING	<ul style="list-style-type: none"> • INSUFFICIENT SOLDER • SOLDERED IN INCORRECT POSITION • CONVEX SOLDERING SPOT • SOLDER BALLS • SOLDER SCRAPS 	
	4.DISPLAY ON (ALL ON)	<ul style="list-style-type: none"> • LIGHT LINE 	

NO.	ITEM	CRITERIA																																	
1	DISPLAY ON INSPECTION	1. INCORRECT PATTERN 2. MISSING SEGMENT 3. DIM SEGMENT 4. OPERATING VOLTAGE BEYOND SPEC																																	
2	OVERALL DIMENSIONS	1. OVERALL DIMENSION BEYOND SPEC																																	
3	DOT DEFECT	<p>1. INSPECTION PATTERN: FULL WHITE, FULL BLACK, RED, GREEN AND BLUE SCREENS.</p> <p>2.</p> <table border="1"> <thead> <tr> <th>DEFECT TYPE</th> <th colspan="2">CRITERIA</th> </tr> <tr> <td>AREA (NOTE 1)</td> <td>I</td> <td>O</td> </tr> </thead> <tbody> <tr> <td>BRIGHT DOTS (NOTE 2)</td> <td>$N \leq 0$</td> <td>$N \leq 1$</td> </tr> <tr> <td>DARK DOTS (NOTE 3)</td> <td>$N \leq 2$</td> <td>$N \leq 2$</td> </tr> <tr> <td>BRIGHT DOT- 2 ADJACENT (NOTE 4)</td> <td colspan="2">$N \leq 0$</td> </tr> <tr> <td>DARK DOTS- 2 ADJACENT (NOTE 5)</td> <td colspan="2">$N \leq 0$</td> </tr> <tr> <td>DARK OR BRIGHT DOTS- 3 AND MORE ADJACENT(NOTE 5)</td> <td colspan="2">$N \leq 0$</td> </tr> <tr> <td>TOTAL BRIGHT AND DARK DOTS (NOTE6)</td> <td colspan="2">$N \leq 3$</td> </tr> <tr> <td>MINIMUM DISTANCE BETWEEN BRIGHT DOTS (NOTE7)</td> <td colspan="2">5 mm</td> </tr> <tr> <td>MINIMUM DISTANCE BETWEEN DARK DOTS (NOTE7)</td> <td colspan="2">5 mm</td> </tr> <tr> <td>MINIMUM DISTANCE BETWEEN DARK AND BRIGHT DOTS (NOTE7)</td> <td colspan="2">5 mm</td> </tr> </tbody> </table> <p>NOTE : (1)DEFINITION OF AREA</p> <p>(2)BRIGHT DOT DEFECT DEFINITION -BRIGHT AREA IS MORE THAN 50% OF ONE DOT. ALL BRIGHT DOT DEFECT MUST BE VISIBLE THROUGH 5% ND FILTER.</p> <p>(3)DARK DOT DEFECT DEFINITION -DARK AREA IS MORE THAN 50% OF ONE DOT . ALL BRIGHT DOT DEFECT MUST BE VISIBLE THROUGH 5% ND FILTER.</p>	DEFECT TYPE	CRITERIA		AREA (NOTE 1)	I	O	BRIGHT DOTS (NOTE 2)	$N \leq 0$	$N \leq 1$	DARK DOTS (NOTE 3)	$N \leq 2$	$N \leq 2$	BRIGHT DOT- 2 ADJACENT (NOTE 4)	$N \leq 0$		DARK DOTS- 2 ADJACENT (NOTE 5)	$N \leq 0$		DARK OR BRIGHT DOTS- 3 AND MORE ADJACENT(NOTE 5)	$N \leq 0$		TOTAL BRIGHT AND DARK DOTS (NOTE6)	$N \leq 3$		MINIMUM DISTANCE BETWEEN BRIGHT DOTS (NOTE7)	5 mm		MINIMUM DISTANCE BETWEEN DARK DOTS (NOTE7)	5 mm		MINIMUM DISTANCE BETWEEN DARK AND BRIGHT DOTS (NOTE7)	5 mm	
DEFECT TYPE	CRITERIA																																		
AREA (NOTE 1)	I	O																																	
BRIGHT DOTS (NOTE 2)	$N \leq 0$	$N \leq 1$																																	
DARK DOTS (NOTE 3)	$N \leq 2$	$N \leq 2$																																	
BRIGHT DOT- 2 ADJACENT (NOTE 4)	$N \leq 0$																																		
DARK DOTS- 2 ADJACENT (NOTE 5)	$N \leq 0$																																		
DARK OR BRIGHT DOTS- 3 AND MORE ADJACENT(NOTE 5)	$N \leq 0$																																		
TOTAL BRIGHT AND DARK DOTS (NOTE6)	$N \leq 3$																																		
MINIMUM DISTANCE BETWEEN BRIGHT DOTS (NOTE7)	5 mm																																		
MINIMUM DISTANCE BETWEEN DARK DOTS (NOTE7)	5 mm																																		
MINIMUM DISTANCE BETWEEN DARK AND BRIGHT DOTS (NOTE7)	5 mm																																		

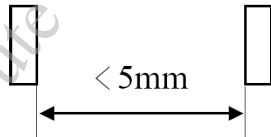
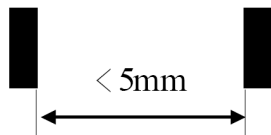
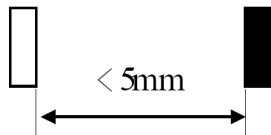
NO.	ITEM	CRITERIA
3	DOT DEFECT	<p>(4) BRIGHT DOT DEFECT DESCRIPTION - TWO ADJACENT</p> <p style="text-align: center;">Type 1</p>      <p>(5) DARK DOT DEFECT DESCRIPTION - TWO ADJACENT</p> <p style="text-align: center;">Type 1</p>  <p style="text-align: center;">Type 2</p>   <p style="text-align: center;">Type 3</p>   <p>(6) DARK DOT DEFECT DESCRIPTION - THREE ADJACENT</p> <p style="text-align: center;">Type 1</p>  <p style="text-align: center;">Type 2</p>   <p style="text-align: center;">Type 3</p>   <p style="text-align: center;">Type 4</p>   <p>(7) MINIMUM DISTANCE BETWEEN DOT DEFECTS</p> <p>BRIGHT DOT TO BRIGHT DOT</p>  <p style="text-align: center;">NG</p> <p>DARK DOT TO DARK DOT</p>  <p style="text-align: center;">NG</p> <p>BRIGHT DOT TO DARK DOT</p>  <p style="text-align: center;">NG</p>

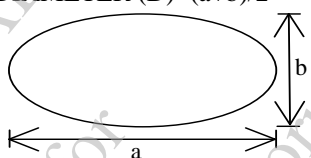
NO.	ITEM	CRITERIA	
		DEFECT TYPE	CRITERIA
4	BUBBLES / PEELING ON POLARIZER	BUBBLE/ PEELING	1. BM: NO COUNT 2. PIXEL AREA 0.15mm≤D<0.5mm,N≤4
		<p>NOTE :</p> <p>(1) POLARIZER BUBBLE IS DEFINED AS THE BUBBLE APPEARS ON ACTIVE DISPLAY AREA. THE DEFECT OF POLARIZER BUBBLE SHALL BE IGNORED IF THE POLARIZER BUBBLE APPEARS ON THE OUTSIDE OF ACTIVE DISPLAY AREA. THE EXTRANEIOUS SUBSTANCE IS DEFINED AS IT CAN BE OBSERVED WHEN THE MODULE IS POWER ON.</p> <p>(2) THE DEFINITION OF AVERAGE DIAMETER, D IS DEFINED AS FOLLOWING. AVERAGE DIAMETER (D)=(a+b)/2</p> 	

CONFIDENTIAL
 Authorized for
 Emerging Display Technologies Corporation Only.
 Do not distribute without authorization.

NO.	ITEM	CRITERIA											
5	BLACK/WHITE SPOT CIRCULAR TYPE	<p>THE FOLLOWING BLACK/WHITE SPOT ARE WITHIN THE VIEWING AREA. AVERAGE DIAMETER : D (mm)</p> <table border="1"> <thead> <tr> <th>SIZE D</th> <th>PERMISSIBLE NO.</th> </tr> </thead> <tbody> <tr> <td>D≤0.15</td> <td>IGNORE</td> </tr> <tr> <td>0.15<D≤0.3</td> <td>5</td> </tr> <tr> <td>0.3<D≤0.5</td> <td>5</td> </tr> <tr> <td>D>0.5</td> <td>0</td> </tr> </tbody> </table> <p>NOTE (1) : THE DISTANCE BETWEEN DEFECTS SHOULD BE MORE THAN 10mm APART. NOTE (2) : VISIBLE UNDER 5% ND FILTER</p>	SIZE D	PERMISSIBLE NO.	D≤0.15	IGNORE	0.15<D≤0.3	5	0.3<D≤0.5	5	D>0.5	0	
SIZE D	PERMISSIBLE NO.												
D≤0.15	IGNORE												
0.15<D≤0.3	5												
0.3<D≤0.5	5												
D>0.5	0												
6	SCRATCH	<p>THE FOLLOWING SCRATCH IS WITHIN THE VIEWING AREA. WIDTH : W (mm) , LENGTH : L (mm)</p> <table border="1"> <thead> <tr> <th>SIZE W & L</th> <th>PERMISSIBLE NO.</th> </tr> </thead> <tbody> <tr> <td>W≤0.1</td> <td>IGNORE</td> </tr> <tr> <td>0.1<W≤0.2, L≤5</td> <td>5</td> </tr> <tr> <td>W>0.2</td> <td>0</td> </tr> </tbody> </table> <p>NOTE (1) : THE DISTANCE BETWEEN DEFECTS SHOULD BE MORE THAN 10mm APART. NOTE (2) : VISIBLE UNDER 5% ND FILTER</p>	SIZE W & L	PERMISSIBLE NO.	W≤0.1	IGNORE	0.1<W≤0.2, L≤5	5	W>0.2	0			
SIZE W & L	PERMISSIBLE NO.												
W≤0.1	IGNORE												
0.1<W≤0.2, L≤5	5												
W>0.2	0												
7	BLACK / WHITE LINE LINEAR TYPE / FOREIGN FIBER	<p>THE FOLLOWING BLACK LINE, WHITE LINE IS WITHIN THE VIEWING AREA. WIDTH : W (mm) , LENGTH : L (mm)</p> <table border="1"> <thead> <tr> <th>SIZE W & L</th> <th>PERMISSIBLE NO.</th> </tr> </thead> <tbody> <tr> <td>W≤0.1</td> <td>IGNORE</td> </tr> <tr> <td>0.1<W≤0.2, L≤5</td> <td>5</td> </tr> <tr> <td>W>0.2</td> <td>0</td> </tr> </tbody> </table> <p>NOTE (1) : THE DISTANCE BETWEEN DEFECTS SHOULD BE MORE THAN 10mm APART. NOTE (2) : VISIBLE UNDER 5% ND FILTER</p>	SIZE W & L	PERMISSIBLE NO.	W≤0.1	IGNORE	0.1<W≤0.2, L≤5	5	W>0.2	0			
SIZE W & L	PERMISSIBLE NO.												
W≤0.1	IGNORE												
0.1<W≤0.2, L≤5	5												
W>0.2	0												
8	BUBBLE / DENT FOR OPTICAL BONDING	<p>BUBBLES WITHIN VIEWING AREA. AVERAGE DIAMETER : D (mm)</p> <table border="1"> <thead> <tr> <th>SIZE D</th> <th>PERMISSIBLE NO.</th> </tr> </thead> <tbody> <tr> <td>D≤0.2</td> <td>IGNORE</td> </tr> <tr> <td>0.2<D≤0.3</td> <td>3</td> </tr> <tr> <td>0.3<D≤0.5</td> <td>2</td> </tr> <tr> <td>D>0.5</td> <td>0</td> </tr> </tbody> </table> <p>NOTE (1) : THE DISTANCE BETWEEN DEFECTS SHOULD BE MORE THAN 10mm APART.</p>	SIZE D	PERMISSIBLE NO.	D≤0.2	IGNORE	0.2<D≤0.3	3	0.3<D≤0.5	2	D>0.5	0	
SIZE D	PERMISSIBLE NO.												
D≤0.2	IGNORE												
0.2<D≤0.3	3												
0.3<D≤0.5	2												
D>0.5	0												
9	CHIPPING	<table border="1"> <tr> <td>CORNER</td> <td>X ≤ 3mm 、 Y ≤ 3mm 、 Z ≤ t (t : THICKNESS)</td> </tr> <tr> <td>EDGE</td> <td>X ≤ 6mm , Y ≤ 1mm , Z < t (t : THICKNESS)</td> </tr> </table>	CORNER	X ≤ 3mm 、 Y ≤ 3mm 、 Z ≤ t (t : THICKNESS)	EDGE	X ≤ 6mm , Y ≤ 1mm , Z < t (t : THICKNESS)							
CORNER	X ≤ 3mm 、 Y ≤ 3mm 、 Z ≤ t (t : THICKNESS)												
EDGE	X ≤ 6mm , Y ≤ 1mm , Z < t (t : THICKNESS)												
10	CRACKED GLASS	NOT ACCEPTABLE											
11	LINE DEFECT ON DISPLAY	OBVIOUS VERTICAL OR HORIZONTAL LINE DEFECT IS NOT ALLOWED.											
12	MURA & LEAK ON DISPLAY	<p>IT'S ACCEPTABLE, IF MURA AND LEAK IS SLIGHT VISIBLE THROUGH 5% ND FILTER.</p>											

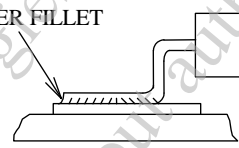
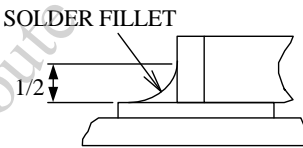
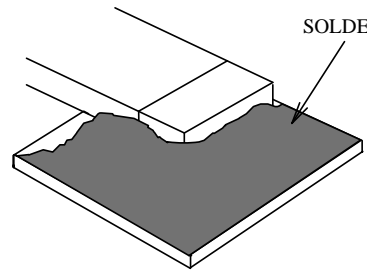
NO.	ITEM	CRITERIA
13	UNEVEN COLOR SPREAD, COLORATION	TO BE DETERMINED BASED UPON THE LIMITED SAMPLE.
14	BEZEL APPEARANCE	<ol style="list-style-type: none"> 1. BEZEL MAY NOT HAVE RUST, BE DEFORMED OR HAVE FINGER PRINTS STAINS OF OTHER CONTAMINATION. 2. BEZEL MUST COMPLY WITH JOB SPECIFICATIONS.
15	PCB	<ol style="list-style-type: none"> 1. THERE MAY NOT BE MORE THAN 2mm OF SEALANT OUTSIDE THE SEAL AREA ON THE PCB, AND THERE SHOULD BE NO MORE THAN THREE PLACES. 2. NO OXIDATION OR CONTAMINATION ON PCB TERMINALS. 3. PARTS ON PCB MUST BE THE SAME AS ON THE PRODUCTION CHARACTERISTIC CHART. THERE SHOULD BE NO WRONG PARTS, MISSING PARTS OR EXCESS PARTS. 4. THE JUMPER ON THE PCB SHOULD CONFORM TO THE PRODUCT CHARACTERISTIC CHART. 5. IF SOLDER GETS ON BEZEL TAB PADS, LED PAD, ZEBRA PAD OR SCREW HOLD PAD; MAKE SURE IT IS SMOOTHED DOWN.
16	SOLDERING	<ol style="list-style-type: none"> 1. NO SOLDERING FOUND ON THE SPECIFIED PLACE 2. INSUFFICIENT SOLDER <ol style="list-style-type: none"> (a) LSI, IC A POOR WETTING OF SOLDER IS BETWEEN LOWER BEND OR "HEEL" OF LEAD AND PAD  (b) CHIP COMPONENT <ul style="list-style-type: none"> · SOLDER IS LESS THAN 50% OF SIDES AND FRONT FACE WETTING  · SOLDER WETS 3 SIDES OF TERMINAL, BUT LESS THAN 25% OF SIDES AND FRONT SURFACE AREA ARE COVERED 

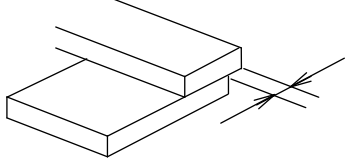
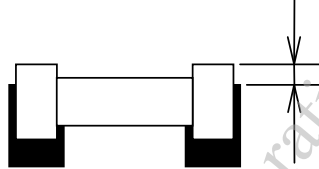
NO.	ITEM	CRITERIA
16	SOLDERING	<p>3. PARTS ALIGNMENT</p> <p>(a) LSI, IC LEAD WIDTH IS MORE THAN 50% BEYOND PAD OUTLINE</p>  <p>(b) CHIP COMPONENT COMPONENT IS OFF CENTER, AND MORE THAN 50% OF THE LEADS IS OFF THE PAD OUTLINE</p>  <p>4. NO UNMELTED SOLDER PASTE MAY BE PRESENT ON THE PCB. 5. NO COLD SOLDER JOINTS, MISSING SOLDER CONNECTIONS, OXIDATION OR ICICLE. 6. NO RESIDUE OR SOLDER BALLS ON PCB. 7. NO SHORT CIRCUITS IN COMPONENTS ON PCB.</p>
17	BACKLIGHT	<p>1. NO LIGHT 2. FLICKERING AND OTHER ABNORMAL ILLUMINATION 3. SPOTS OR SCRATCHES THAT APPEAR WHEN LIT MUST BE JUDGED USING LCD SPOT, LINES AND CONTAMINATION STANDARDS. 4. BACKLIGHT DOESN'T LIGHT OR COLOR IS WRONG.</p>
18	GENERAL APPEARANCE	<p>1. NO OXIDATION, CONTAMINATION, CURVES OR, BENDS ON INTERFACE PIN (OLB) OF TCP. 2. NO CRACKS ON INTERFACE PIN (OLB) OF TCP. 3. NO CONTAMINATION, SOLDER RESIDUE OR SOLDER BALLS ON PRODUCT. 4. THE IC ON THE TCP MAY NOT BE DAMAGED, CIRCUITS. 5. THE UPPERMOST EDGE OF THE PROTECTIVE STRIP ON THE INTERFACE PIN MUST BE PRESENT OR LOOK AS IF IT CAUSE THE INTERFACE PIN TO SEVER. 6. THE RESIDUAL ROSIN OR TIN OIL OF SOLDERING (COMPONENT OR CHIP COMPONENT) IS NOT BURNED INTO BROWN OR BLACK COLOR. 7. SEALANT ON TOP OF THE ITO CIRCUIT HAS NOT HARDENED. 8. PIN TYPE MUST MATCH TYPE IN SPECIFICATION SHEET. 9. LCD PIN LOOSE OR MISSING PINS. 10. PRODUCT PACKAGING MUST BE THE SAME AS SPECIFIED ON PACKAGING SPECIFICATION SHEET. 11. PRODUCT DIMENSION AND STRUCTURE MUST CONFORM TO PRODUCT SPECIFICATION SHEET. 12. THE APPEARANCE OF HEAT SEAL SHOULD NOT ADMIT ANY DIRT AND BREAK.</p>

NOTE :

- FOR ANY SPOTS OR LINES, WHICH ARE NOT OBSERVED UNDER APPROPRIATE PANEL OPERATING CONDITION ARE DEEMED ACCEPTABLE.
- THE FOREIGN MATERIALS THAT CAN BE BLOWN OUT BY AIR AND REMOVED BY WET CLEANING ARE NOT REGARDED AS DEFECTS.

14. RELIABILITY TEST

14.1 STANDARD SPECIFICATIONS FOR RELIABILITY OF LCD MODULE

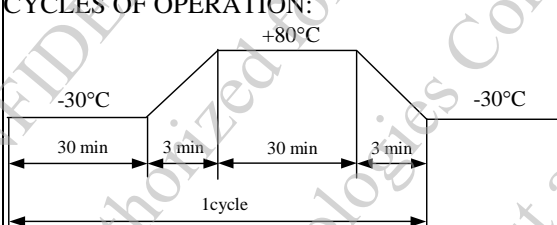
NO.	ITEM	DESCRIPTION
1	HIGH TEMPERATURE OPERATION	THE SAMPLE SHOULD BE ALLOWED TO STAND AT +70°C FOR 168 HRS
2	LOW TEMPERATURE OPERATION	THE SAMPLE SHOULD BE ALLOWED TO STAND AT -20°C FOR 168 HRS
3	HIGH TEMPERATURE STORAGE	THE SAMPLE SHOULD BE ALLOWED TO STAND AT +80°C FOR 168 HRS
4	LOW TEMP STORAGE	THE SAMPLE SHOULD BE ALLOWED TO STAND AT -30°C FOR 168 HRS
5	HIGH TEMPERATURE /HUMIDITY TEST STORAGE	THE SAMPLE SHOULD BE ALLOWED TO STAND AT 50°C, 85% RH 168 HRS
6	THERMAL SHOCK (NOT OPERATED)	<p>THE SAMPLE SHOULD BE ALLOWED TO STAND THE FOLLOWING 1 CYCLES OF OPERATION:</p> 
7	ESD (ELECTROSTATIC DISCHARGE) (NOT OPERATED)	<p>AIR DISCHARGE ± 8KV CONTACT DISCHARGE ± 4KV ACCORDING TO IEC-61000-4-2</p>

NOTE (1) : THE TEST SAMPLES HAVE RECOVERY TIME FOR 2 HOURS AT ROOM TEMPERATURE BEFORE THE FUNCTION CHECK. IN THE STANDARD CONDITIONS, THERE IS NO DISPLAY FUNCTION FAILURE ISSUE OCCURRED.

14.2 TESTING CONDITIONS AND INSPECTION CRITERIA

FOR THE FINAL TEST THE TESTING SAMPLE MUST BE STORED AT ROOM TEMPERATURE FOR 24 HOURS, AFTER THE TESTS LISTED IN TABLE 14.1, STANDARD SPECIFICATIONS FOR RELIABILITY HAVE BEEN EXECUTED IN ORDER TO ENSURE STABILITY.

NO.	ITEM	TEST MODEL	INSPECTION CRITERIA
1	CURRENT CONSUMPTION	REFER TO SPECIFICATION	THE CURRENT CONSUMPTION SHOULD CONFORM TO THE PRODUCT SPECIFICATION.
2	CONTRAST	REFER TO SPECIFICATION	AFTER THE TESTS HAVE BEEN EXECUTED, THE CONTRAST MUST BE LARGER THAN HALF OF ITS INITIAL VALUE PRIOR TO THE TESTS.
3	APPEARANCE	VISUAL INSPECTION	DEFECT FREE

15. CAUTION

15.1 OPERATION

- 15.1.1 DO NOT CONNECT OR DISCONNECT MODULES TO OR FROM THE MAIN SYSTEM WHILE POWER IS BEING SUPPLIED .
- 15.1.2 USE THE MODULE WITHIN SPECIFIED TEMPERATURE ; LOWER TEMPERATURE CAUSES THE RETARDATION OF BLINKING SPEED OF THE DISPLAY ; HIGHER TEMPERATURE MAKES OVERALL DISPLAY DISCOLOR. WHEN THE TEMPERATURE RETURNS TO NORMALITY, THE DISPLAY WILL OPERATE NORMALLY .
- 15.1.3 ADJUST THE LC DRIVING VOLTAGE TO OBTAIN THE OPTIMUM CONTRAST.
- 15.1.4 POWER ON SEQUENCE INPUT SIGNALS SHOULD NOT BE SUPPLIED TO LCD MODULE BEFORE POWER SUPPLY VOLTAGE IS APPLIED AND REACHES THE SPECIFIED VALUE .
IF ABOVE SEQUENCE IS NOT FOLLOWED , CMOS LSIS OF LCD MODULES MAY BE DAMAGED DUE TO LATCH - UP PROBLEM .
- 15.1.5 NOT ALLOWED TO INFLICT ANY EXTERNAL STRESS AND TO CAUSE ANY MECHANICAL INTERFERENCE ON THE BENDING AREA OF FPC DURING THE TAIL BENDING BACKWARDS!
DO NOT STRESS FPC AND IC ON THE MODULE!

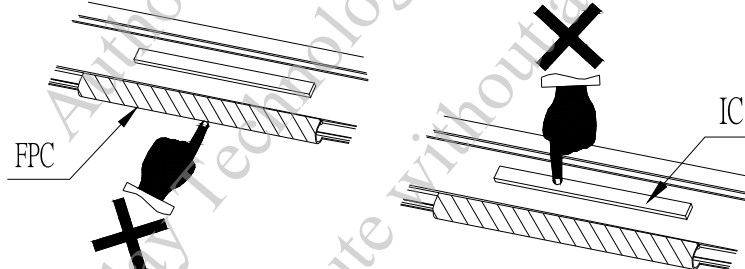

15.2 HANDLING

- 15.2.1 USE A GROUNDED SOLDERING IRON WHEN SOLDERING CONNECTOR I/O TERMINALS . FOR SOLDERING OR REPAIRING, TAKE PRECAUTION AGAINST THE TEMPERATURE OF THE SOLDERING IRON AND THE SOLDERING TIME TO PREVENT PEELING OFF THE THROUGH-HOLE-PAD .
- 15.2.2 DO NOT DISASSEMBLE . EDT SHALL NOT BE HELD RESPONSIBLE IF THE MODULE IS DISASSEMBLED AND UPON THE REASSEMBLY THE MODULE FAILED .
- 15.2.3 DO NOT CHARGE STATIC ELECTRICITY , AS THE CIRCUIT OF THIS MODULE CONTAINS CMOS LSIS. A WORKMAN'S BODY SHOULD ALWAYS BE STATIC-PROTECTED BY USE OF AN ESD STRAP. WORKING CLOTHES FOR SUCH PERSONNEL SHOULD BE OF STATIC-PROTECTED MATERIAL .
- 15.2.4 ALWAYS GROUND THE ELECTRICALLY-POWERED DRIVER BEFORE USING IT TO INSTALL THE LCD MODULE. WHILE CLEANING THE WORK STATION BY VACUUM CLEANER, DO NOT BRING THE SUCKING MOUTH NEAR THE MODULE ; STATIC ELECTRICITY OF THE ELECTRICALLY-POWERED DRIVER OR THE VACUUM CLEANER MAY DESTROY THE MODULE .
- 15.2.5 DON'T GIVE EXTERNAL SHOCK.
- 15.2.6 DON'T APPLY EXCESSIVE FORCE ON THE SURFACE.
- 15.2.7 LIQUID CRISTAL IN LCD IS HAZARDOUS SUBSTANCE. MUST NOT LICK AND SWALLOW.
WHEN THE LIQUID IS ATTACH TO YOUR, SKIN, CLOTH ETC.
WASH IT OUT THOROUGHLY AND IMMEDIATELY.
- 15.2.8 DON'T OPERATE IT ABOVE THE ABSOLUTE MAXIMUM RATING.
- 15.2.9 STORAGE IN A CLEAN ENVIRONMENT, FREE FROM DUST, ACTIVE GAS, AND SOLVENT.
- 15.2.10 STORE WITHOUT ANY PHYSICAL LOAD.
- 15.2.11 REWIRING: NO MORE THAN 3 TIMES.