

SPECIFICATIONS

CUSTOMER : _____
SAMPLE CODE : SH102600T009-IBC
MASS PRODUCTION CODE : PH102600T009-IBC
SAMPLE VERSION : 01
SPECIFICATIONS EDITION : 003
DRAWING NO. (Ver.) : LMD-PH102600T009-IBC (Ver.001)
PACKAGING NO. (Ver.) : PKG- PH102600T009-IBC (Ver.001)

Customer Approved

Date:

Approved	Checked	Designer
廖志豪 Rex Liao	張慶源 Yuan Chang	陳宗淇 Howard Chen

- Preliminary specification for design input
- Specification for sample approval

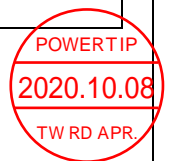

POWERTIP TECH. CORP.

Headquarters:

No.8, 6th Road, Taichung Industrial Park,
 Taichung, Taiwan
 台中市 407 工業區六路 8 號

TEL: 886-4-2355-8168
 FAX: 886-4-2355-8166

E-mail: sales@powertip.com.tw
 Http://www.powertip.com.tw

Contents

1. SPECIFICATIONS

- 1.1 Features
- 1.2 Mechanical Specifications
- 1.3 Absolute Maximum Ratings
- 1.4 DC Electrical Characteristics
- 1.5 Optical Characteristics
- 1.6 Backlight Characteristics
- 1.7 Touch Panel Characteristics

2. MODULE STRUCTURE

- 2.1 Counter Drawing
- 2.2 Interface Pin Description
- 2.3 Timing Characteristics
- 2.4 AC Electrical Characteristics
- 2.5 Timing

3. QUALITY ASSURANCE SYSTEM

- 3.1 Quality Assurance Flow Chart
- 3.2 Inspection Specification

4. RELIABILITY TEST

- 4.1 Reliability Test Condition

5. PRECAUTION RELATING PRODUCT HANDLING

- 5.1 Safety
- 5.2 Handling
- 5.3 Storage
- 5.4 Terms of Warranty

Appendix : 1.LCM Drawing

2. Packing Specification

1. SPECIFICATIONS

1.1 Features

Item	Standard Value
Display Type	1024 * 3 (RGB) * 600 Dots
LCD Type	a-Si TFT , Normally white , Transmissive type
Screen size(inch)	7.0 inch
Viewing Direction	6 O'clock (Gray scale Inversion)
	12 O'clock
Color configuration	RGB-Strip
Backlight Type	White LED B/L
Interface	24Bit RGB Interface
ROHS	THIS PRODUCT CONFORMS THE ROHS OF PTC Detail information please refer website : http://www.powertip.com.tw/news_detail.php?Key=1&cID=1

1.2 Mechanical Specifications

Item	Standard Value	Unit
Outline Dimension	192.96 (L) * 110.76 (W) * 5.54 (H)(max)	mm

LCD Panel

Item	Standard Value	Unit
Active Area	154.21(L) * 85.92(W)	mm
Pixel Size	0.1506 (W) * 0.1432 (H)	mm

Note : For detailed information please refer to LCM drawing

1.3 Absolute Maximum Ratings

Module

Item	Symbol	Min.	Max.	Unit
Power Voltage	VDD	-0.5	5.0	V
	AVDD	-0.5	15.0	V
	VGH	-0.3	42.0	V
	VGL	-20.0	-0.3	V
Operating Temperature	T _{OP}	-20	70	°C
Storage Temperature	T _{ST}	-30	80	°C

1.4 DC Electrical Characteristics

Module

GND = 0V, Ta = 25°C

Item	Symbol	Min.	Typ.	Max.	Unit	Remark
Supply Voltage	V _{DD}	2.5	3.3	3.6	V	-
	V _{GH}	19.7	20.0	20.3		
	V _{GL}	-7.1	-6.8	-6.5		
	AV _{DD}	8.0	11.0	13.5		
V _{COM}	V _{COM}	3.3	3.8	4.3	V	
Input signal Voltage	V _{IH}	0.7V _{DD}	-	V _{DD}	V	
	V _{IL}	0	-	0.3V _{DD}		
Supply Current	I (V _{DD})	-	15	25	mA	Pattern=R,G,B *1
	I (AV _{DD})	-	20	30		Pattern= Black
	I _{GH}	-	0.2	0.3		Pattern=R,G,B
	I _{GL}	-	0.2	0.3		Pattern= R,G,B

Note1: Maximum current display.

1.5 Optical Characteristics

TFT LCD Module

DVDD = 3.3 V, Ta=25°C

Item	Symbol		Condition	Min.	Typ.	Max.	unit	
Response time	Tr		Ta = 25°C θX, θY = 0°	-	10	20	ms	Note 2
	Tf			15	30			
Viewing angle	Top	θY+	CR ≥ 10	-	70	-	Deg.	Note 4
	Bottom	θY-		-	75	-		
	Left	θX-		-	75	-		
	Right	θX+		-	75	-		
Contrast ratio		CR		500	800	-		Note 3
Color of CIE Coordinate (With B/L & T/P)	White	X	Ta = 25°C θX , θY = 0°	0.26	0.31	0.36	-	Note1
		Y		0.27	0.32	0.37		
	Red	X		0.60	0.65	0.70		
		Y		0.29	0.34	0.39		
	Green	X		0.27	0.32	0.37		
		Y		0.55	0.60	0.65		
	Blue	X		0.09	0.14	0.19		
		Y		0.00	0.05	0.10		
Average Brightness Pattern=white display (With LCD & T/P)*1	IV		IF= 200mA	320	400	-	cd/m ²	Note1
Uniformity (With LCD& T/P)*2	ΔB		IF= 200mA	70	-	-	%	Note1

Note 1:

*1 : $\Delta B = B(\text{min}) / B(\text{max}) * 100\%$

*2 : Measurement Condition for Optical Characteristics:

a : Environment: $25^{\circ}\text{C} \pm 5^{\circ}\text{C}$ / $60 \pm 20\% \text{R.H}$, no wind , dark room below 10 Lux at typical lamp current and typical operating frequency.

b : Measurement Distance: 500 ± 50 mm , ($\theta = 0^{\circ}$)

c : Equipment: TOPCON BM-7 fast , (field 1°) , after 10 minutes operation.

d : The uncertainty of the C.I.E coordinate measurement ± 0.01 , Average Brightness $\pm 4\%$

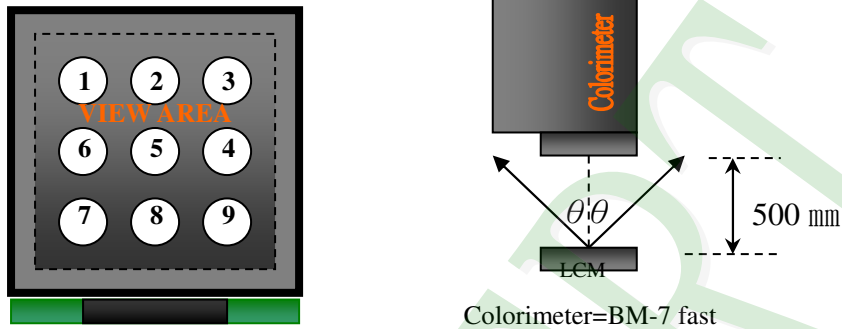

To be measured at the center area of panel with a viewing cone of 1° by Topcon luminance meter BM-7, after 10 minutes operation (module)

Note2: Definition of response time:

The output signals of photo detector are measured when the input signals are changed from "black" to "white"(falling time) and from "white" to "black"(rising time), respectively. The response time is defined as the time interval between the 10% and 90% of Amplitudes.

Refer to figure as below:

Normally White



Normally Black

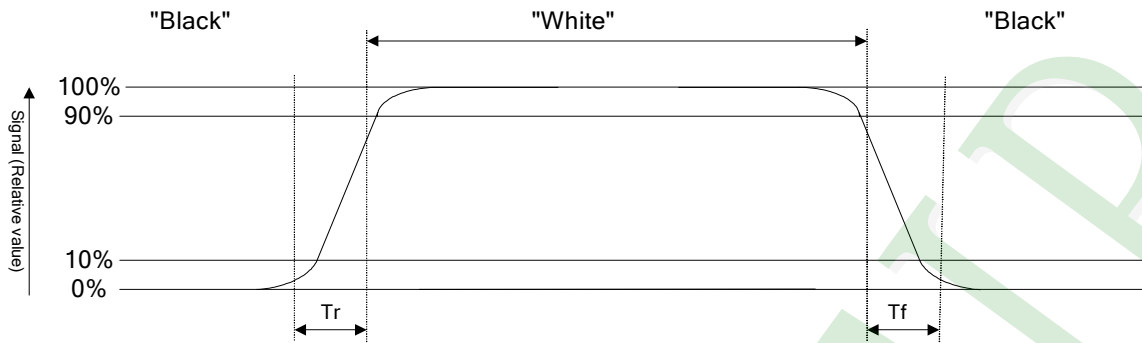

Note3: Definition of contrast ratio:

Contrast ratio is calculated with the following formula

$$\text{Contrast ratio (CR)} = \frac{\text{Photo detector output when LCD is at "White" state}}{\text{Photo detector output when LCD is at "Black" state}}$$

Note4: Definition of viewing angle:

Refer to figure as below:

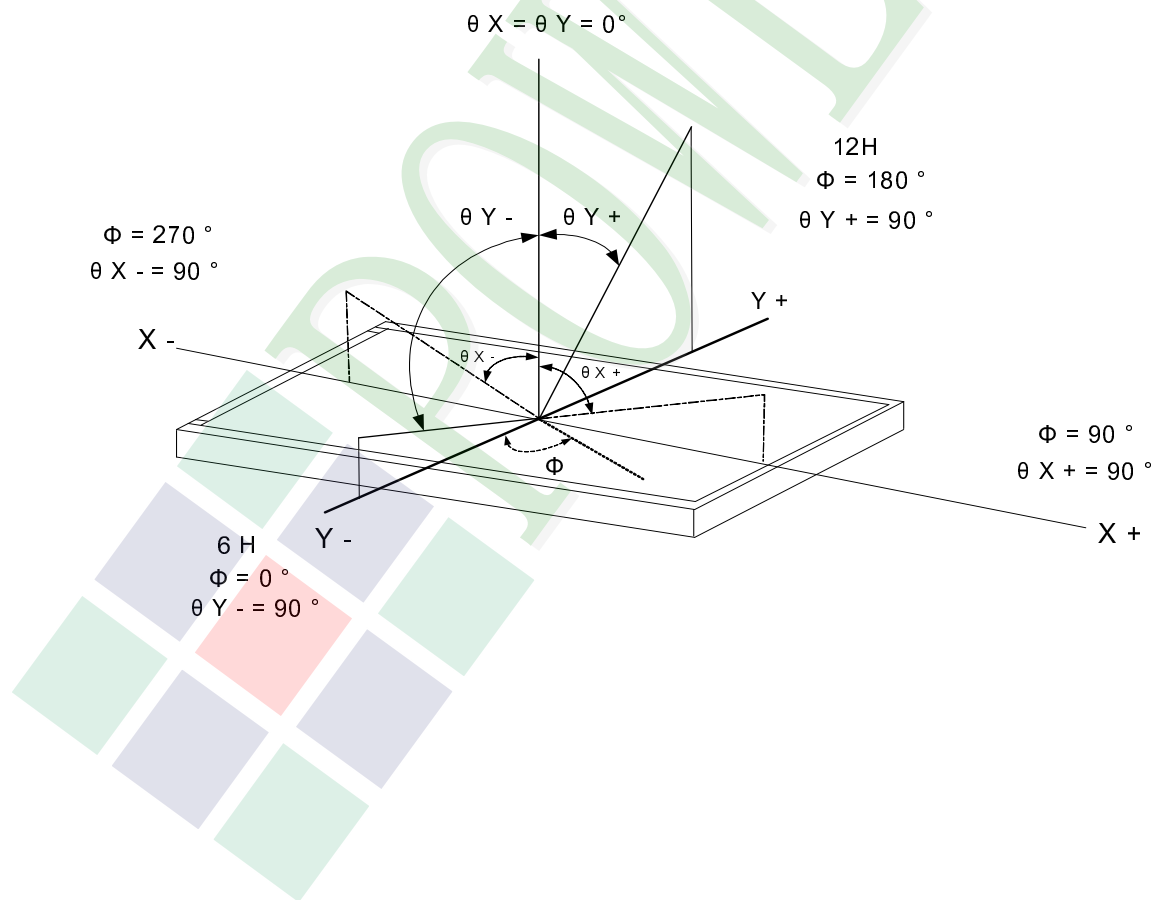

1.6 Backlight Characteristics

Maximum Ratings

Item	Symbol	Conditions	Min.	Max.	Unit
LED Forward Current	IF	Ta =25°C	-	300	mA
LED Reverse Voltage	VR		-	5	V
Power consumption	Pd			3060	mW

Electrical / Optical Characteristics

Item	Symbol	Conditions	Min.	Typ.	Max.	Unit
Forward Voltage	VF	If= 200 mA	8.7	9.6	10.2	V
Average Brightness (Without LCD)	IV		14000	16200		cd/m ²
CIE Color Coordinate (Without LCD)	X		-	0.305	-	-
	Y		-	0.315	-	
Color	White					

B/L Internal Circuit Diagram:

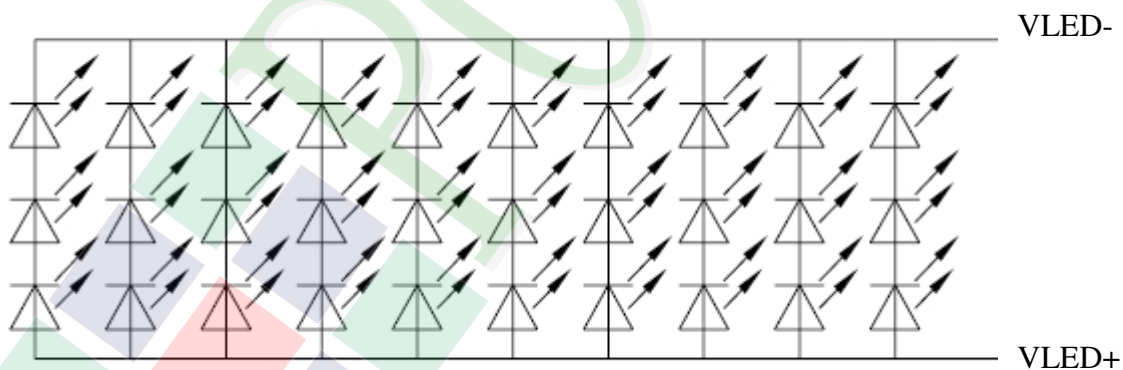

Other Description

Item	Conditions	Description
Life Time	Ta =25°C IF= 200mA	20,000 hrs

1.7 Touch Panel Characteristics

Features

Item	Standard Value
Touch Panel Size	7.0"
Touch type	True Multi-Touch Capacitive Touch Panel
Input Method	True Multi-touch with up to 5 Points of Absolution X and Y Coordinates
Output Interface	I ² C
IC	FT5426
I2C Address	0x70

Mechanical Specifications

Item	Standard Value	Unit
Viewing Area	155.05 mm (W) x 86.72 mm (H)	mm

Absolute Maximum Ratings

Item	Symbol	Condition	Min.	Max.	Unit
Supply voltage	TPVDD	-	-0.3	3.6	V
Operating Temperature	T _{OP}	Non condenssing	-20	70	°C
Storage Temperature	T _{ST}	Non condenssing	-30	80	°C

DC Electrical Characteristics

Item	Symbol	Condition	Min.	Typ.	Max.	Unit
Power Supply Voltage	TPVDD	-	3.0	3.3	3.6	V
Input High Voltage	V _{IH}	-	0.7 TPVDD	-	TPVDD	V
Input Low Voltage	V _{IL}	-	-0.3	-	0.3 TPVDD	V
Output High Voltage	V _{OH}	I _{OH} =-0.1mA	0.7 TPVDD	-	-	V
Output Low Voltage	V _{OL}	I _{OL} =+0.1mA	-	-	0.3 TPVDD	V

Optical Characteristics

Item	Standard Value	Unit
Total light transmittance	85% or more	-

I²C Read/Write Interface description

Write N bytes to I2C slave

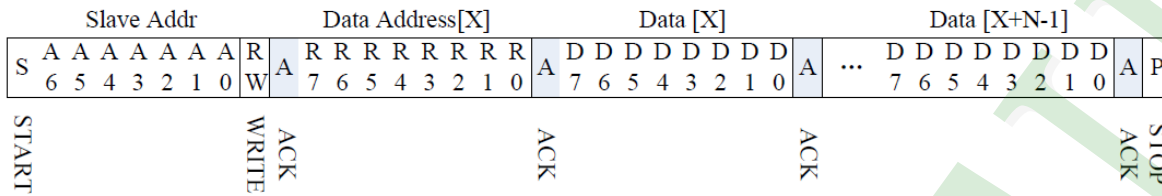

Set Data Address

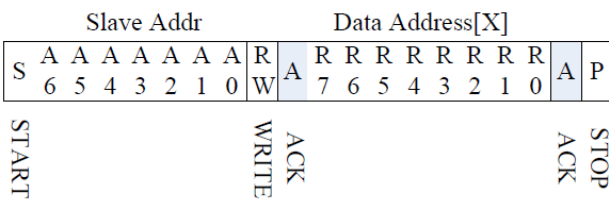

Read X bytes from I2C Slave

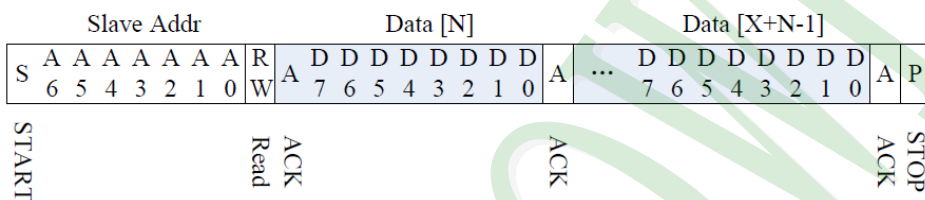

Mnemonics Description

Mnemonics	Description
S	I2C Start or I2C Restart
A[6:0]	Slave address A[6:0]:0111000b
R/ W	'1' for read, '0'for write
A(N)	ACK(NACK)
P	STOP: the indication of the end of a packet (if this bit is missing, S will indicate the end of the current packet and the beginning of the next packet)

Timing Characteristics

Parameter	Unit	Min	Max
SCL frequency	KHz	0	400
Bus free time between a STOP and START condition	us	4.7	∞
Hold time (repeated) START condition	us	4.0	∞
Data setup time	ns	250	∞
Setup time for a repeated START condition	us	4.7	∞
Setup Time for STOP condition	us	4.0	∞

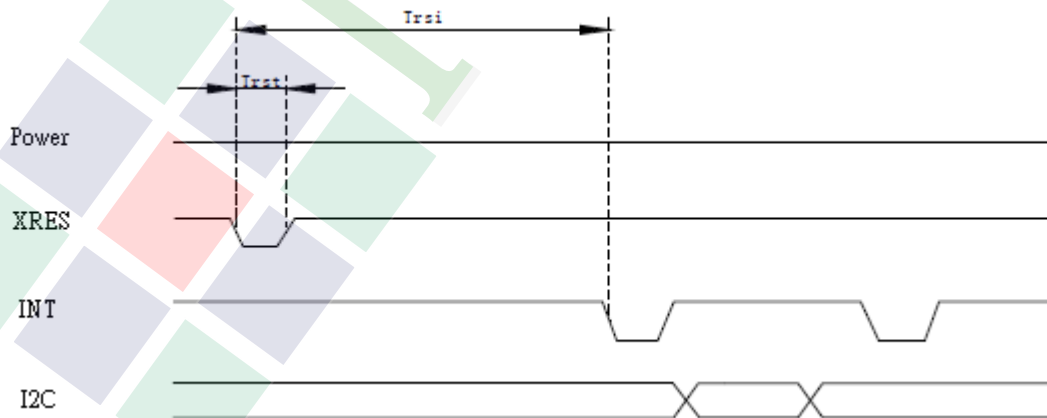
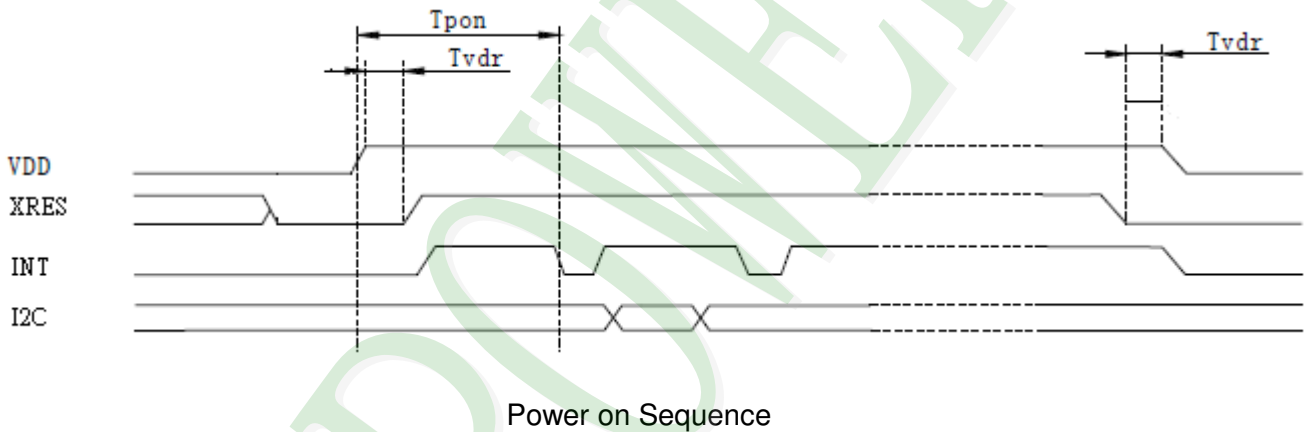
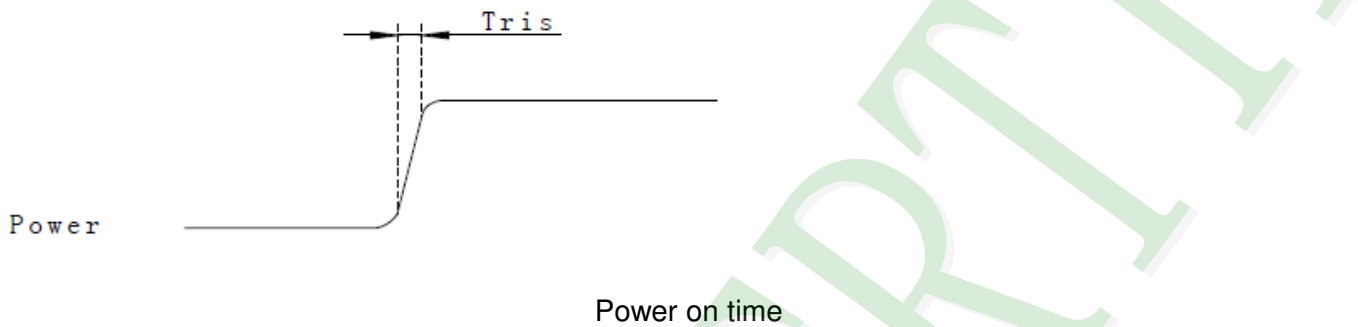

Power on / Reset Sequence Parameters

Parameter	Description	Min	Max	Units
Tris	Rise time from 0.1VDD to 0.9VDD	--	5	ms
Tpon	Time of starting to report point after powering on	200	--	ms
Tvdr	Reset time after VDD powering on	1	--	ms
Trsi	Time of starting to report point after resetting	200	--	ms
Trst	Reset time	1	--	ms

Interrupt signal from CTP to Host

As for standard CTP, host need to use both interrupt control signal and serial data interface to get the touch data. There are two kind of method to use interrupt: interrupt trigger and interrupt query.

Here is the timing to get touch data.

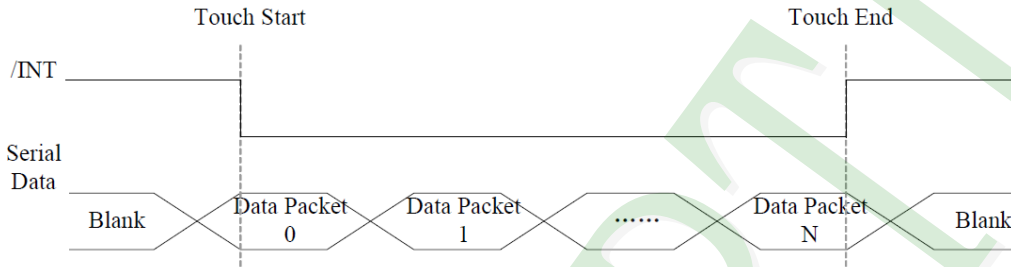

Interrupt query mode

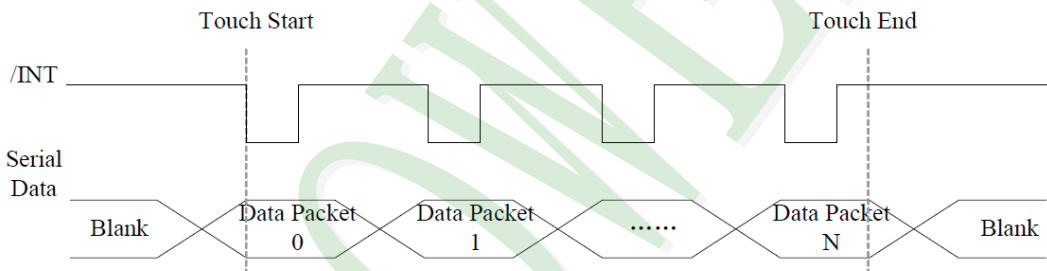

Interrupt trigger mode

Host use general I2C protocol to read the touch data or the information from CTP . CTP will send host a interrupt signal when there is a valid touch. Then host can use the serial data interface to get the touch data. If there is no valid touch detected, the /INT will not be pulled up, the host do not need to read the touch data.

NOTE: “valid touch” may have different definition in various systems. For example, in some systems, the valid touch is defined as there is one more valid touch point. But in some other systems, the valid touch is defined as one more valid touch with valid gestures. In usual, /INT will be pulled up when there is a valid touch point, and to be low when a touch finishes.

As for interrupt trigger mode, /INT signal will be low if there is a touch detected. But for per update of valid touch data, CTP will produce a valid pulse for /INT signal, host can read the touch data periodically according to the frequency of this pulse. In this mode, the pulse frequency is the touch data update frequency.

CTP Register Mapping

Address	Name	Bit7	Bit6	Bit5	Bit4	Bit3	Bit2	Bit1	Bit0	Host Access
00h	DEVIDE_MODE	-	Device Mode[2:0]			-	-	-	-	WR
01h	GEST_ID	Gesture ID[7:0]								R
02h	TD_STATUS	-	-	-	-	Number of touch points[3:0]				R
03h	TOUCH1_XH	1st Event Flag		-	-	1st Touch X Position[11:8]				R
04h	TOUCH1_XL	1st Touch X Position[7:0]								R
05h	TOUCH1_YH	1st Touch ID[3:0]			1st Touch Y Position[11:8]					R
06h	TOUCH1_YL	1st Touch Y Position[7:0]								R
07h	-	-								R
08h	-	-								R
09h	TOUCH2_XH	2st Event Flag		-	-	2st Touch X Position[11:8]				R
0Ah	TOUCH2_XL	2st Touch X Position[7:0]								R
0Bh	TOUCH2_YH	2st Touch ID[3:0]			2st Touch Y Position[11:8]					R
0Ch	TOUCH2_YL	2st Touch Y Position[7:0]								R
0Dh	-	-								R
0Eh	-	-								R
0Fh	TOUCH3_XH	3st Event Flag		-	-	3st Touch X Position[11:8]				R
10h	TOUCH3_XL	3st Touch X Position[7:0]								R
11h	TOUCH3_YH	3st Touch ID[3:0]			3st Touch Y Position[11:8]					R
12h	TOUCH3_YL	3st Touch Y Position[7:0]								R
13h	-	-								R
14h	-	-								R
15h	TOUCH4_XH	4st Event Flag		-	-	4st Touch X Position[11:8]				R
16h	TOUCH4_XL	4st Touch X Position[7:0]								R
17h	TOUCH4_YH	4st Touch ID[3:0]			4st Touch Y Position[11:8]					R
18h	TOUCH4_YL	4st Touch Y Position[7:0]								R
19h	-	-								R
1Ah	-	-								R
1Bh	TOUCH5_XH	5st Event Flag		-	-	5st Touch X Position[11:8]				R
1Ch	TOUCH5_XL	5st Touch X Position[7:0]								R
1Dh	TOUCH5_YH	5st Touch ID[3:0]			5st Touch Y Position[11:8]					R
1Eh	TOUCH5_YL	5st Touch Y Position[7:0]								R
1Fh	-	-								R
20h	-	-								R

Address	Name	Bit7	Bit6	Bit5	Bit4	Bit3	Bit2	Bit1	Bit0	Host Access
21h	TOUCH6_XH	6st Event Flag		-	-	6st Touch X Position[11:8]				R
22h	TOUCH6_XL	6st Touch X Position[7:0]								R
23h	TOUCH6_YH	6st Touch ID[3:0]			6st Touch Y Position[11:8]					R
24h	TOUCH6_YL	6st Touch Y Position[7:0]								R
25h	-	-								R
26h	-	-								R
27h	TOUCH7_XH	7st Event Flag		-	-	7st Touch X Position[11:8]				R
28h	TOUCH7_XL	7st Touch X Position[7:0]								R
29h	TOUCH7_YH	7st Touch ID[3:0]			7st Touch Y Position[11:8]					R
2ah	TOUCH7_YL	7st Touch Y Position[7:0]								R
2bh	-	-								R
2ch	-	-								R
2dh	TOUCH8_XH	8st Event Flag		-	-	8st Touch X Position[11:8]				R
2eh	TOUCH8_XL	8st Touch X Position[7:0]								R
2fh	TOUCH8_YH	8st Touch ID[3:0]			8st Touch Y Position[11:8]					R
30h	TOUCH8_YL	8st Touch Y Position[7:0]								R
31h	-	-								R
32h	-	-								R
33h	TOUCH9_XH	9st Event Flag		-	-	9st Touch X Position[11:8]				R
34h	TOUCH9_XL	9st Touch X Position[7:0]								R
35h	TOUCH9_YH	9st Touch ID[3:0]			9st Touch Y Position[11:8]					R
36h	TOUCH9_YL	9st Touch Y Position[7:0]								R
37h	-	-								R
38h	-	-								R
39h	TOUCH10_XH	10st Event Flag		-	-	10st Touch X Position[11:8]				R
3ah	TOUCH10_XL	10st Touch X Position[7:0]								R
3bh	TOUCH10_YH	10st Touch ID[3:0]			10st Touch Y Position[11:8]					R
3ch	TOUCH10_YL	10st Touch Y Position[7:0]								R
3dh	-	-								R
3eh	-	-								R
3fh	-	-								R

DEVICE_MODE

This register is the device mode register, configure it to determine the current mode of the chip.

Address	Bit Address	Register Name	Description
00h	6 : 4	Device Mode [2:0]	000b Work Mode 100b Factory Mode – read raw data

GEST_ID

This register describes the gesture of a valid touch.

Address	Bit Address	Register Name	Description
01h	7 : 0	Gesture ID [7:0]	0x10 Move UP 0x14 Move Left 0x18 Move Down 0x1C Move Right 0x48 Zoom In 0x49 Zoom Out

TD_STATUS

This register is the Touch Data status register.

Address	Bit Address	Register Name	Description
02h	7 : 4	Reserved	
	3 : 0	Number of touch points[3:0]	How many points detected. 1-5 is valid.

TOUCHn_XH

This register describes MSB of the X coordinate of the nth touch point and the corresponding event flag.

Address	Bit Address	Register Name	Description
03h ~ 39h	7 : 6	Event Flag	00b: Put Down 01b: Put Up 10b: Contact 11b: Reserved
	5 : 4		Reserved
	3 : 0	Touch X Position [11:8]	MSB of Touch X Position in pixels

TOUCHn_XL

This register describes LSB of the X coordinate of the nth touch point

Address	Bit Address	Register Name	Description
04h ~ 3Ah	7 : 0	Touch X Position [7:0]	LSB of the Touch X Position in pixels

TOUCHn_YH

This register describes MSB of the Y coordinate of the nth touch point and corresponding touch ID.

Address	Bit Address	Register Name	Description
05h ~ 3Bh	7 : 4	Touch ID[3:0]	Touch ID of Touch Point
	3 : 0	Touch Y Position [11:8]	MSB of Touch Y Position in pixels

TOUCHn_YL

This register describes LSB of the Y coordinate of the nth touch point.

Address	Bit Address	Register Name	Description
06h ~ 3Ch	7:0	Touch Y Position[7:0]	LSB of The Touch Y Position in pixels

2. MODULE STRUCTURE

2.1 Counter Drawing

2.1.1 LCM Mechanical Diagram

* See Appendix

2.1.2 Block Diagram

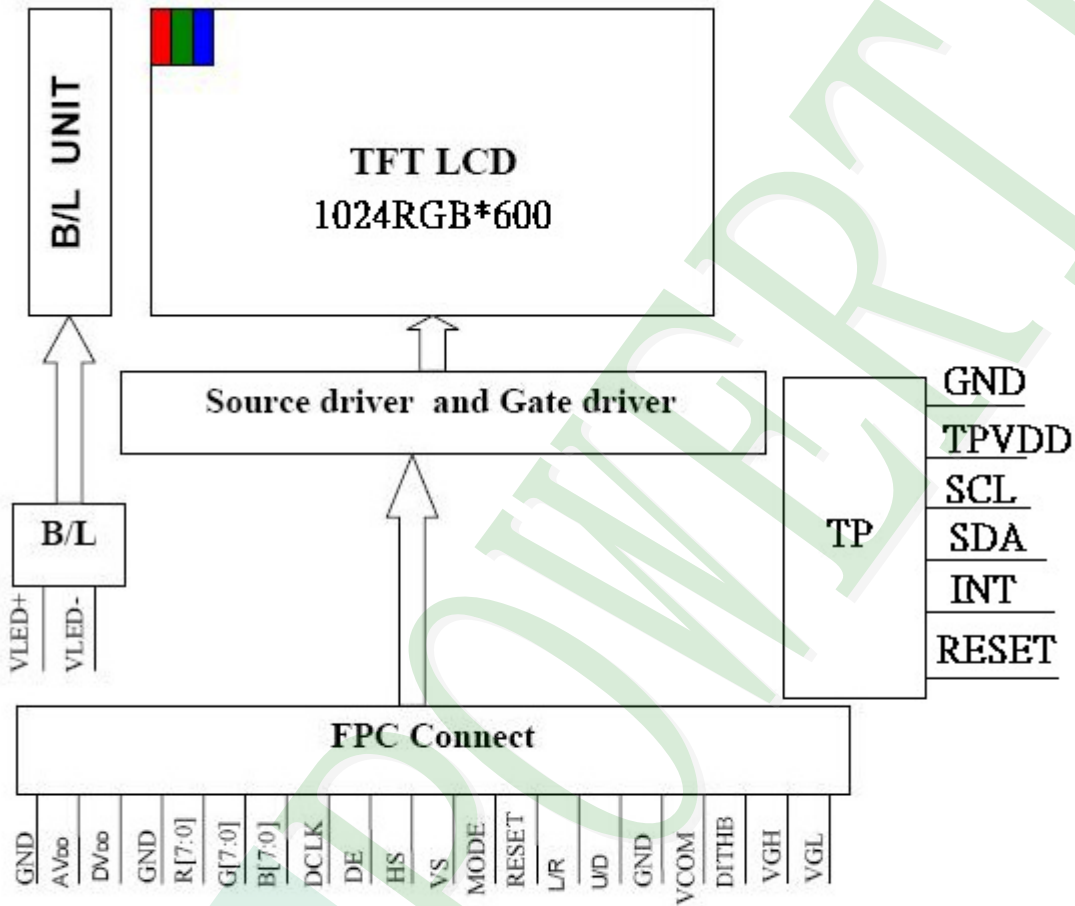

2.2 Interface Pin Description

Pin NO.	SYMBOL	DESCRIPTION
1	V _{LED+}	Power For LED backlight (+).
2	V _{LED+}	Power For LED backlight (+).
3	V _{LED-}	Power For LED backlight (-).
4	V _{LED-}	Power For LED backlight (-).
5	GND	Power ground.
6	V _{com}	Common voltage.
7	DV _{DD}	Power for Digital Circuit.
8	MODE	DE/SYNC mode select. Normally pull high. H: DE mode. L: HSD/VSD mode.
9	DE	Data Input Enable.
10	VS	Vertical Sync Input.
11	HS	Horizontal Sync Input.
12	B7	Blue Data(MSB).
13	B6	Blue Data.
14	B5	Blue Data.
15	B4	Blue Data.
16	B3	Blue Data.
17	B2	Blue Data.
18	B1	Blue Data.
19	B0	Blue Data(LSB).
20	G7	Green Data(MSB).
21	G6	Green Data.
22	G5	Green Data.
23	G4	Green Data.
24	G3	Green Data.
25	G2	Green Data.
26	G1	Green Data.
27	G0	Green Data(LSB).
28	R7	Red Data(MSB).
29	R6	Red Data.
30	R5	Red Data.
31	R4	Red Data.
32	R3	Red Data.
33	R2	Red Data.
34	R1	Red Data.
35	R0	Red Data(LSB).
36	GND	Power Ground

Pin NO.	SYMBOL	DESCRIPTION
37	DCLK	Sample clock
38	GND	Power Ground.
39	L/R	Left / right selection.
40	U/D	Left / right selection.
41	V _{GH}	Gate On Voltage.
42	V _{GL}	Gate OFF Voltage.
43	AV _{DD}	Power for Analog Circuit.
44	RESET	Global reset pin.
45	NC	No connection.
46	V _{COM}	Common Voltage.
47	DITHB	Dithering Function.
48	GND	Power Ground.
49	NC	No connection.
50	NC	No connection.

Capacitive Touch Panel (CTP) Interface

Pin No.	Symbol	Function
1	GND	Ground.
2	TPVDD	Power.
3	SCL	I ² C Clock.
4	SDA	I ² C Data.
5	INT	The interrupt from the CTP to the Host H: CTP interrupt not requested L: CTP request interrupt
6	RESET	RESET.

Note1:L/R : left or right setting

U/D : up or down setting

L/R	U/D	Data shifting
DVDD	GND	Left→Right , Up→Down(default)
GND	GND	Right→Left , Up→Down
DVDD	DVDD	Left→Right , Down→Up
GND	DVDD	Right→Left , Down→Up

Definition of scanning direction:

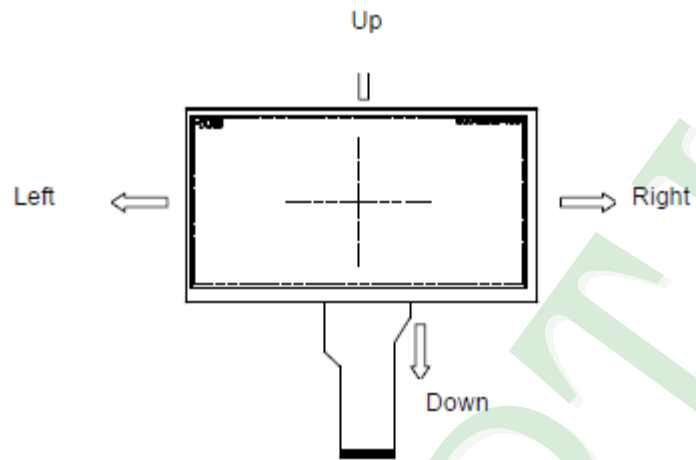

Note2: DE MODE: DE Stay LOW, Synchronous RGB Data , HS VS=NC
HSD/VSD MODE: HS VS Synchronous RGB Data ,DE=GND

2.3 Timing Characteristics

2.3.1 Power Sequence

In order to prevent IC from power on reset fail, the rising time (T_{POR}) of the digital power supply VDD should be maintained within the given specifications. Refer to "AC Characteristics" for more detail on timing.

Power-On/Off Timing Sequence:

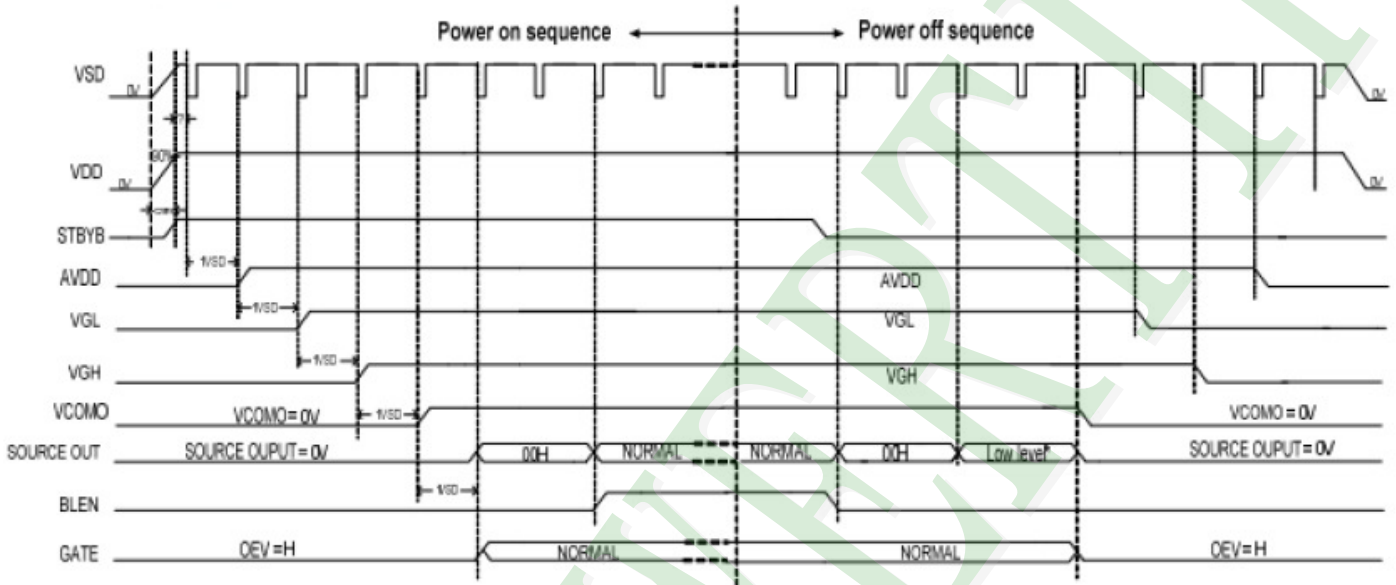

Enter and Exit Standby Mode Sequence:

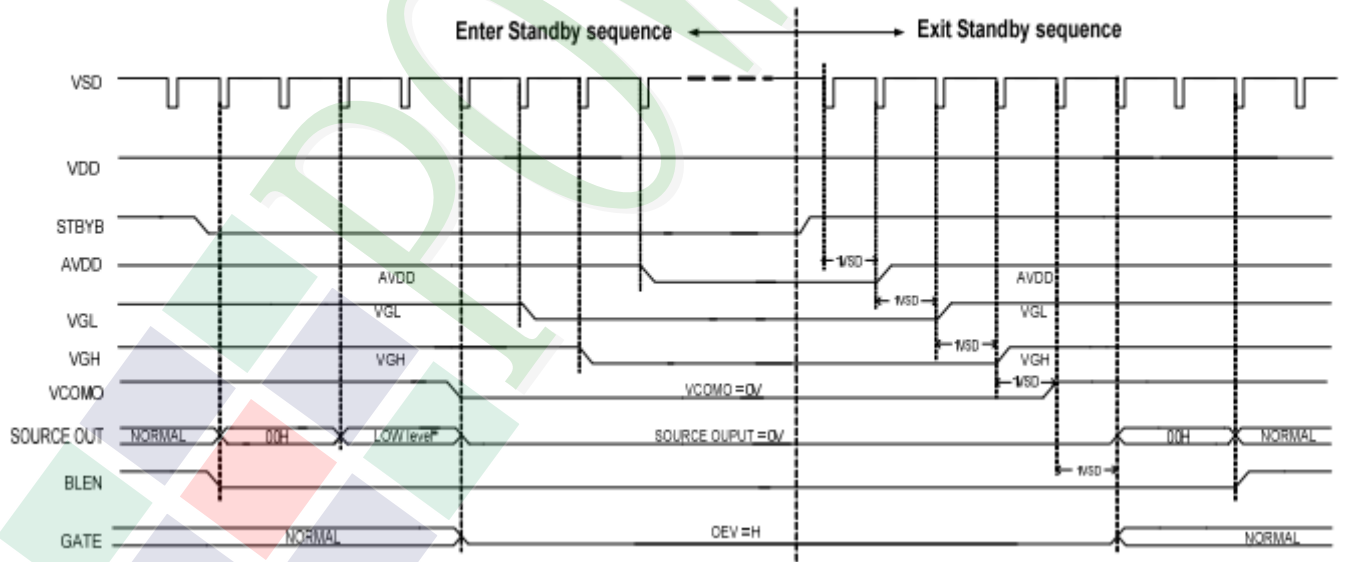

2.3.2 Input Clock and Data Timing Diagram

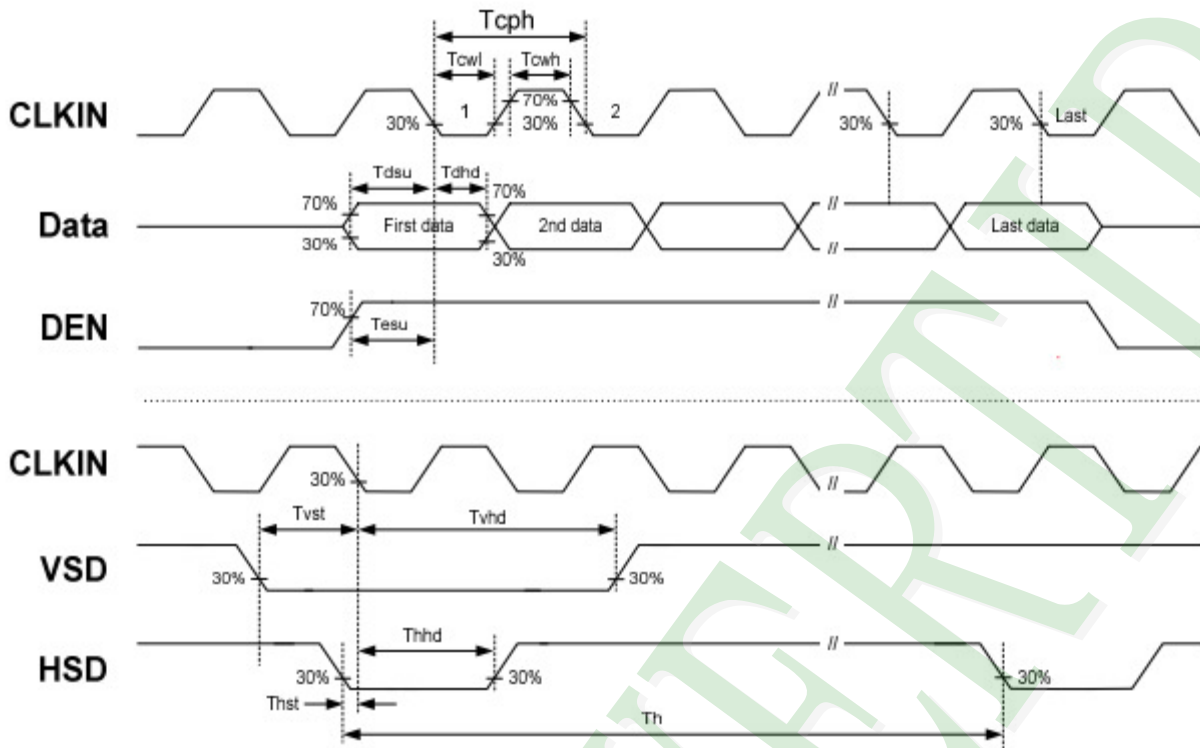

Vertical Timing Diagram HV (Cascade)

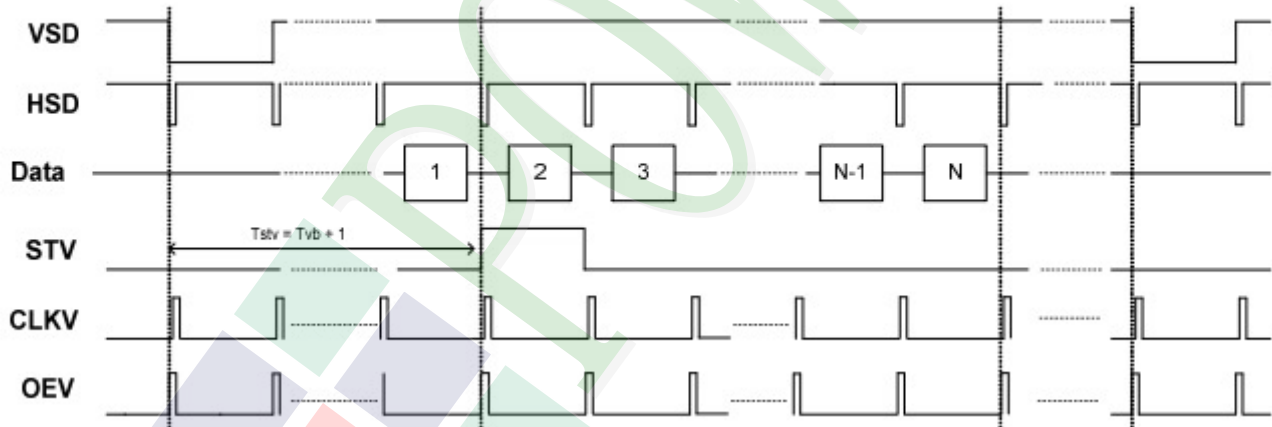

Vertical Timing Diagram DE (Cascade)

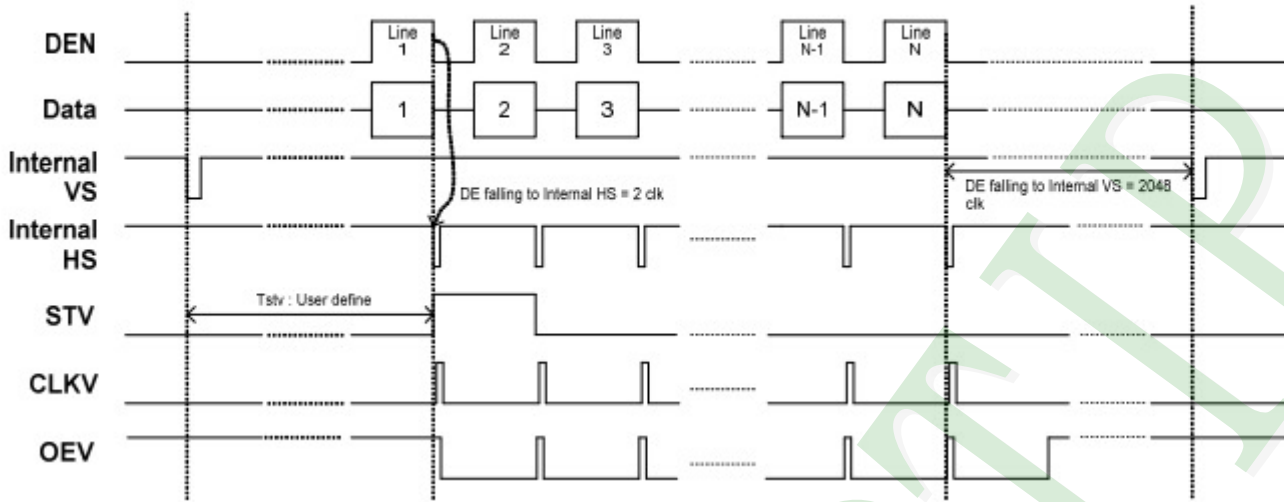

Gate output timing diagram (Cascade)

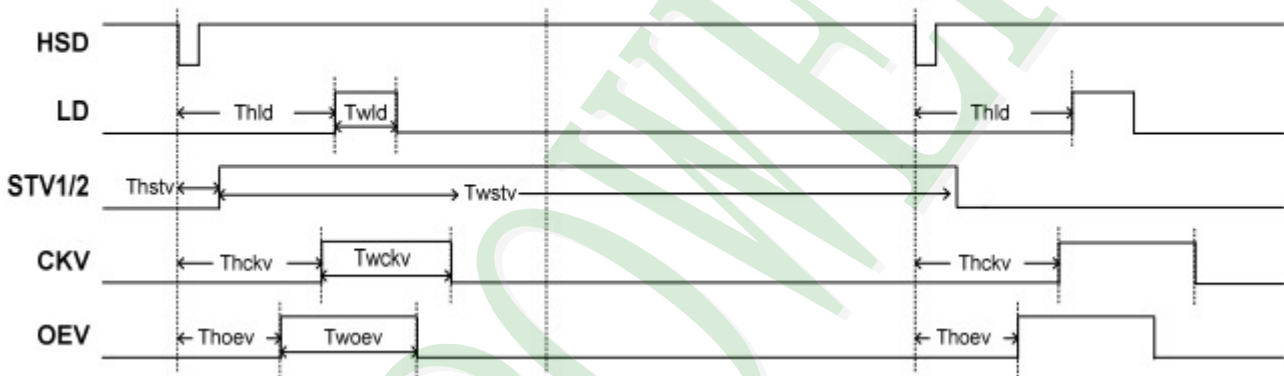

2.3.3 Parallel RGB input timing table

DE Mode

Parameter	Symbol	Value			Unit
		Min	Typ	Max	
Horizontal display area	thd	1024			DCLK
DCLK frequency@ Frame rate=60HZ	fclk	40.8	51.2	67.2	MHz
HSYNC period time	th	1114	1344	1400	DCLK
HSYNC blacking	Thb+Thfp	90	320	376	DCLK
Vertical display area	tvd	600			H
VSYNC period time	tv	610	635	800	H
VSYNC blacking	Tvb+Tvfp	10	35	200	H

HV Mode

Horizontal input timing

Parameter	Symbol	Value			Unit
		Min	Typ	Max	
Horizontal display area	thd	1024			DCLK
DCLK frequency@ Frame rate=60HZ	fclk	44.9	51.2	63	MHz
1 Horizontal Line	th	1200	1344	1400	DCLK
HSYNC pulse width	Min	-	1	-	
	Typ	-	-	-	
	Max	-	140	-	
HSYNC Blacking	thp	160	160	160	
HSYNC Front Proch	thfb	16	160	216	

Vertical input timing

Parameter	Symbol	Value			Unit
		Min	Typ	Max	
Vertical display area	tvd	600			H
VSYNC period time	tv	624	635	750	H
VSYNC pulse width	tvpw	1	-	20	H
VSYNC Blanking	tvb	23	23	23	H
VSYNC Front Porch	tvfb	1	12	127	H

2.4 AC Electrical Characteristics

Parameters	Symbol	Spec			Unit	Conditions
		Min.	Typ.	Max.		
VDD Power ON slew rate	tPOR	--	--	20	ms	0V ~ 90% VDD
RSTB pulse width	trST	50	--	--	us	CLKIN=65MHz
DCLK cycle time	tCPH	14	--	--	ns	
DCLK pulse duty	tcWH	40	50	60	%	
VSD setup time	tvST	5	--	--	ns	
VSD hold time	tvHD	5	--	--	ns	
HSD setup time	thST	5	--	--	ns	
HSD hold time	thHD	5	--	--	ns	
Data setup time	tdST	5	--	--	ns	D0[7:0], D1[7:0], D2[7:0] to DCLK
Data hold time	tdHD	5	--	--	ns	D0[7:0], D1[7:0], D2[7:0] to DCLK
DE setup time	teST	5	--	--	ns	
DE hold time	teHD	5	--	--	ns	
Output stable time	tsST	--	--	6	us	10% to 90% target voltage. CL=90pF, R=10K
				3		Dual gate

3. QUALITY ASSURANCE SYSTEM

3.1 Quality Assurance Flow Chart

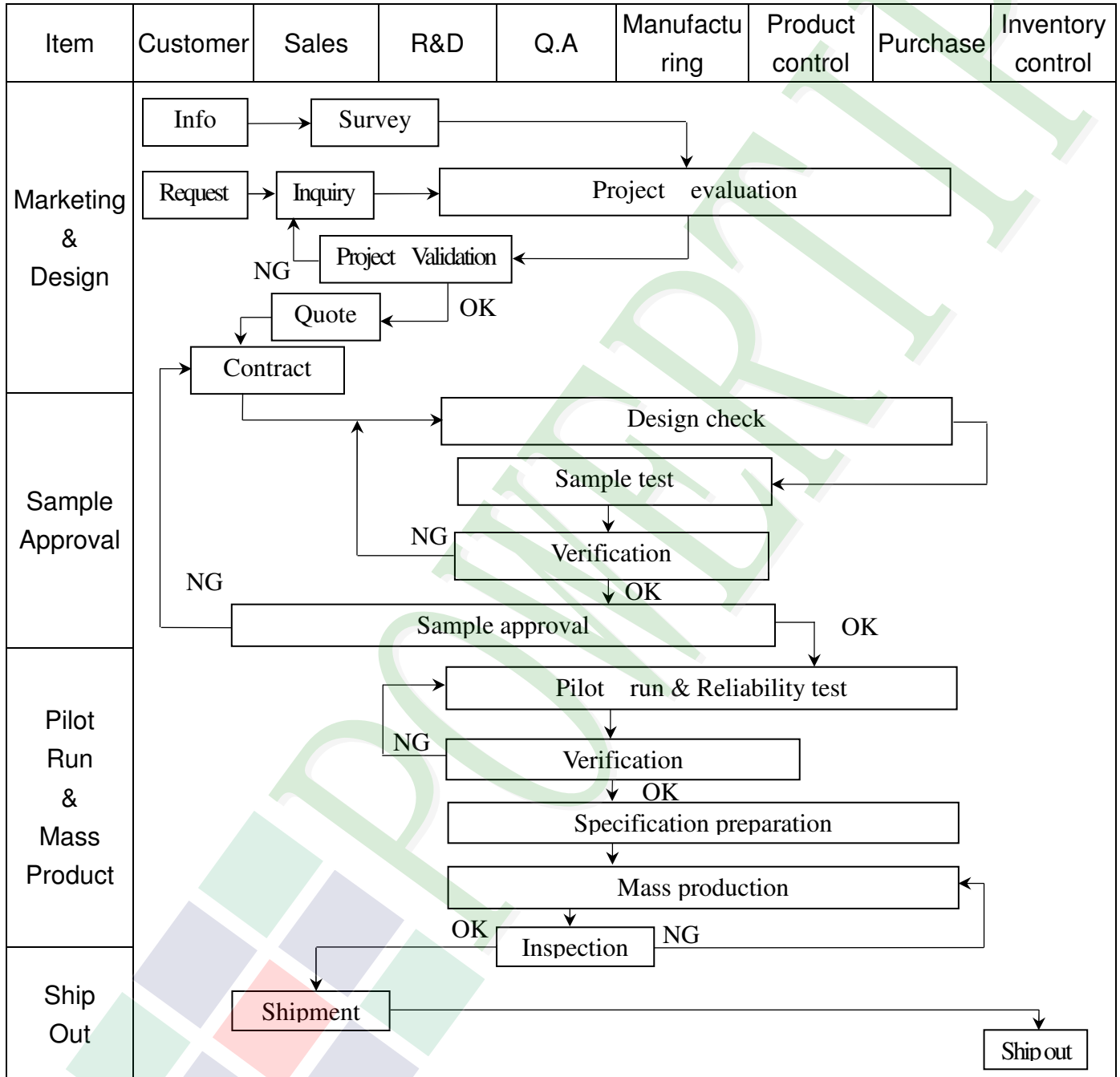

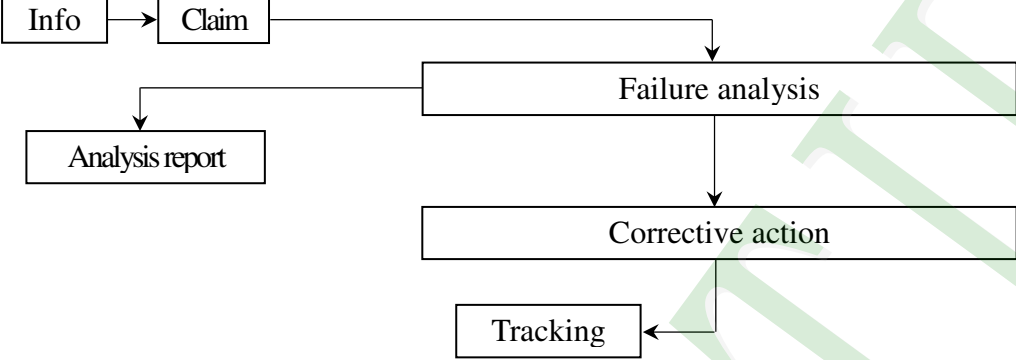
Item	Customer	Sales	R&D	Q.A	Manufacturing	Product control	Purchase	Inventory control
Sales Service	 <pre> graph TD Info[Info] --> Claim[Claim] Claim --> Failure[Failure analysis] Failure --> Report[Analysis report] Failure --> Action[Corrective action] Action --> Tracking[Tracking] </pre>							
Q.A Activity	1. ISO 9001 Maintenance Activities 3. Equipment calibration 5. Standardization Management				2. Process improvement proposal 4. Education And Training Activities			

3.2. Inspection Specification

◆Scope : The document shall be applied to TFT-LCD Module for 3.5" ~15" (Ver.B01).

◆Inspection Standard : MIL-STD-105E Table Normal Inspection Single Sampling Level II.

◆Equipment : Gauge 、 MIL-STD 、 Powertip Tester 、 Sample

◆Defect Level : Major Defect AQL : 0.4 ; Minor Defect AQL : 1.5

◆OUT Going Defect Level : Sampling.

◆Standard of the product appearance test :

a. Manner of appearance test :

(1). The test best be under 20W×2 fluorescent light , and distance of view must be at 30 cm.

(2). The test direction is base on about around 45° of vertical line.

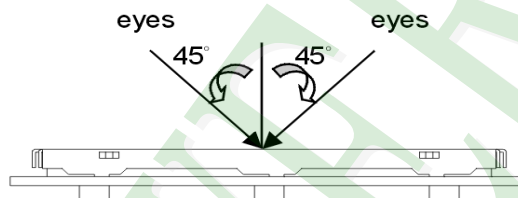

(3). Definition of area.

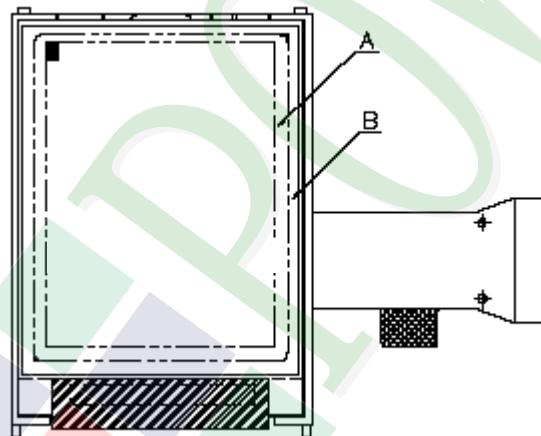

A area : viewing area

B area : Outside of viewing area

(4). Standard of inspection : (Unit : mm)

◆Specification For TFT-LCD Module 3.5" ~15" :
(Ver.B01)

NO	Item	Criterion	Level												
01	Product condition	1. 1 The part number is inconsistent with work order of production.	Major												
		1. 2 Mixed product types.	Major												
		1. 3 Assembled in inverse direction.	Major												
02	Quantity	2. 1 The quantity is inconsistent with work order of production.	Major												
03	Outline dimension	3. 1 Product dimension and structure must conform to structure diagram.	Major												
04	Electrical Testing	4. 1 Missing line character and icon.	Major												
		4. 2 No function or no display.	Major												
		4. 3 Display malfunction.	Major												
		4. 4 LCD viewing angle defect.	Major												
		4. 5 Current consumption exceeds product specifications.	Major												
		4. 6 Mura can not be seen through 5% ND filter. (Mura : Under the normal examination angle of view, the picture has the non-uniform phenomenon.)	Minor												
05	Dot defect (Bright dot 、 Dark dot) On -display	<table border="1" style="margin-left: auto; margin-right: auto;"> <thead> <tr> <th colspan="2">Item</th> <th>Acceptance (Q'ty)</th> </tr> </thead> <tbody> <tr> <td rowspan="4" style="text-align: center; vertical-align: middle;">Dot Defect</td> <td style="text-align: center;">Bright Dot</td> <td style="text-align: center;">≤ 4</td> </tr> <tr> <td style="text-align: center;">Dark Dot</td> <td style="text-align: center;">≤ 5</td> </tr> <tr> <td style="text-align: center;">Joint Dot</td> <td style="text-align: center;">≤ 3</td> </tr> <tr> <td style="text-align: center;">Total</td> <td style="text-align: center;">≤ 7</td> </tr> </tbody> </table>	Item		Acceptance (Q'ty)	Dot Defect	Bright Dot	≤ 4	Dark Dot	≤ 5	Joint Dot	≤ 3	Total	≤ 7	Minor
		Item		Acceptance (Q'ty)											
		Dot Defect	Bright Dot	≤ 4											
			Dark Dot	≤ 5											
			Joint Dot	≤ 3											
Total	≤ 7														
5. 1 Inspection pattern : full white , full black , Red , Green and blue screens.															
5. 2 It is defined as dot defect if defect area $> 1/2$ dot.															
5. 3 The distance between two dot defect ≥ 5 mm.															
5. 4 Bright dot that can not be seen through 5% ND filter.															

◆Specification For TFT-LCD Module 3.5" ~15" :

(Ver.B01)

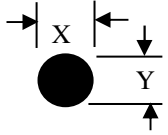
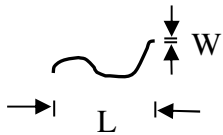
NO	Item	Criterion	Level																																											
06	Black or white dot、scratch、contamination Round type  $\Phi = (x + y) / 2$ Line type 	6.1 Round type (Non-display or display) : <table border="1"> <thead> <tr> <th rowspan="2">Dimension (diameter : Φ)</th> <th colspan="2">Acceptance (Q'ty)</th> </tr> <tr> <th>A area</th> <th>B area</th> </tr> </thead> <tbody> <tr> <td>$\Phi \leq 0.25$</td> <td colspan="2">Ignore</td> </tr> <tr> <td>$0.25 < \Phi \leq 0.50$</td> <td>5</td> <td rowspan="3">Ignore</td> </tr> <tr> <td>$\Phi > 0.50$</td> <td>0</td> </tr> <tr> <td>Total</td> <td>5</td> </tr> </tbody> </table>	Dimension (diameter : Φ)	Acceptance (Q'ty)		A area	B area	$\Phi \leq 0.25$	Ignore		$0.25 < \Phi \leq 0.50$	5	Ignore	$\Phi > 0.50$	0	Total	5	Minor																												
		Dimension (diameter : Φ)		Acceptance (Q'ty)																																										
A area	B area																																													
$\Phi \leq 0.25$	Ignore																																													
$0.25 < \Phi \leq 0.50$	5	Ignore																																												
$\Phi > 0.50$	0																																													
Total	5																																													
6.2 Line type(Non-display or display) : <table border="1"> <thead> <tr> <th rowspan="2">module size</th> <th rowspan="2">Length (L)</th> <th rowspan="2">Width (W)</th> <th colspan="2">Acceptance (Q'ty)</th> </tr> <tr> <th>A area</th> <th>B area</th> </tr> </thead> <tbody> <tr> <td rowspan="4">3.5" to less 9"</td> <td>---</td> <td>$W \leq 0.03$</td> <td colspan="2">Ignore</td> </tr> <tr> <td>$L \leq 10.0$</td> <td>$0.03 < W \leq 0.05$</td> <td>4</td> <td rowspan="4">Ignore</td> </tr> <tr> <td>$L \leq 5.0$</td> <td>$0.05 < W \leq 0.10$</td> <td>2</td> </tr> <tr> <td>---</td> <td>$W > 0.10$</td> <td colspan="2">As round type</td> </tr> <tr> <td colspan="3">Total</td> <td colspan="2">5</td> </tr> <tr> <td rowspan="4">9" to 15"</td> <td>---</td> <td>$W \leq 0.05$</td> <td colspan="2">Ignore</td> </tr> <tr> <td>$L \leq 10.0$</td> <td>$0.05 < W \leq 0.10$</td> <td>5</td> <td rowspan="4">Ignore</td> </tr> <tr> <td>---</td> <td>$W > 0.10$</td> <td colspan="2">As round type</td> </tr> <tr> <td colspan="3">Total</td> <td colspan="2">5</td> </tr> </tbody> </table>	module size	Length (L)	Width (W)	Acceptance (Q'ty)		A area	B area	3.5" to less 9"	---	$W \leq 0.03$	Ignore		$L \leq 10.0$	$0.03 < W \leq 0.05$	4	Ignore	$L \leq 5.0$	$0.05 < W \leq 0.10$	2	---	$W > 0.10$	As round type		Total			5		9" to 15"	---	$W \leq 0.05$	Ignore		$L \leq 10.0$	$0.05 < W \leq 0.10$	5	Ignore	---	$W > 0.10$	As round type		Total			5	
module size				Length (L)	Width (W)	Acceptance (Q'ty)																																								
	A area	B area																																												
3.5" to less 9"	---	$W \leq 0.03$	Ignore																																											
	$L \leq 10.0$	$0.03 < W \leq 0.05$	4	Ignore																																										
	$L \leq 5.0$	$0.05 < W \leq 0.10$	2																																											
	---	$W > 0.10$	As round type																																											
Total			5																																											
9" to 15"	---	$W \leq 0.05$	Ignore																																											
	$L \leq 10.0$	$0.05 < W \leq 0.10$	5	Ignore																																										
	---	$W > 0.10$	As round type																																											
	Total				5																																									
07	Polarizer Bubble	<table border="1"> <thead> <tr> <th rowspan="2">Dimension (diameter : Φ)</th> <th colspan="2">Acceptance (Q'ty)</th> </tr> <tr> <th>A area</th> <th>B area</th> </tr> </thead> <tbody> <tr> <td>$\Phi \leq 0.25$</td> <td colspan="2">Ignore</td> </tr> <tr> <td>$0.25 < \Phi \leq 0.50$</td> <td>4</td> <td rowspan="4">Ignore</td> </tr> <tr> <td>$0.50 < \Phi \leq 0.80$</td> <td>1</td> </tr> <tr> <td>$\Phi > 0.80$</td> <td>0</td> </tr> <tr> <td>Total</td> <td>5</td> </tr> </tbody> </table>	Dimension (diameter : Φ)		Acceptance (Q'ty)		A area	B area	$\Phi \leq 0.25$	Ignore		$0.25 < \Phi \leq 0.50$	4	Ignore	$0.50 < \Phi \leq 0.80$	1	$\Phi > 0.80$	0	Total	5	Minor																									
Dimension (diameter : Φ)	Acceptance (Q'ty)																																													
	A area	B area																																												
$\Phi \leq 0.25$	Ignore																																													
$0.25 < \Phi \leq 0.50$	4	Ignore																																												
$0.50 < \Phi \leq 0.80$	1																																													
$\Phi > 0.80$	0																																													
Total	5																																													

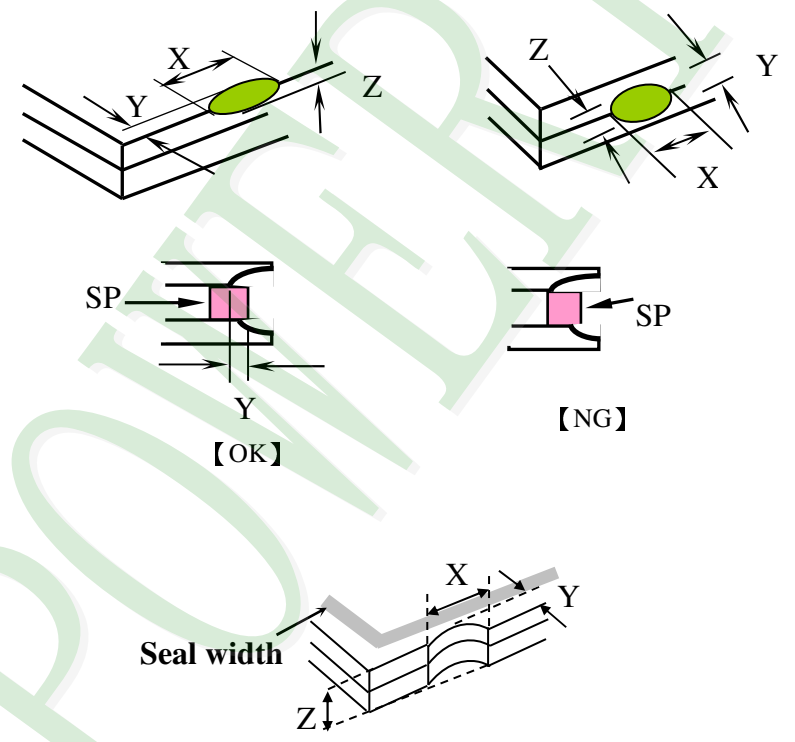
NO	Item	Criterion	Level									
08	The crack of glass	<p>Symbols :</p> <p>X : The length of crack Z : The thickness of crack t : The thickness of glass</p> <p>Y : The width of crack. W : terminal length a : LCD side length</p> <hr/> <p>8.1 General glass chip :</p> <p>8.1.1 Chip on panel surface and crack between panels:</p>  <p>The diagrams illustrate various crack types: a surface chip with length X, width Y, and thickness Z; a crack between panels with terminal length SP and width Y; and a crack at the seal with length X, width Y, and thickness Z. The seal width is also indicated.</p> <table border="1" data-bbox="539 1579 1353 1870"> <thead> <tr> <th>X</th> <th>Y</th> <th>Z</th> </tr> </thead> <tbody> <tr> <td>$\leq a$</td> <td>Crack can't enter viewing area</td> <td>$\leq 1/2 t$</td> </tr> <tr> <td>$\leq a$</td> <td>Crack can't exceed the half of SP width.</td> <td>$1/2 t < Z \leq 2 t$</td> </tr> </tbody> </table>	X	Y	Z	$\leq a$	Crack can't enter viewing area	$\leq 1/2 t$	$\leq a$	Crack can't exceed the half of SP width.	$1/2 t < Z \leq 2 t$	Minor
		X	Y	Z								
$\leq a$	Crack can't enter viewing area	$\leq 1/2 t$										
$\leq a$	Crack can't exceed the half of SP width.	$1/2 t < Z \leq 2 t$										
<table border="1"> <thead> <tr> <th>X</th> <th>Y</th> <th>Z</th> </tr> </thead> <tbody> <tr> <td>$\leq a$</td> <td>Crack can't enter viewing area</td> <td>$\leq 1/2 t$</td> </tr> <tr> <td>$\leq a$</td> <td>Crack can't exceed the half of SP width.</td> <td>$1/2 t < Z \leq 2 t$</td> </tr> </tbody> </table>	X	Y	Z	$\leq a$	Crack can't enter viewing area	$\leq 1/2 t$	$\leq a$	Crack can't exceed the half of SP width.	$1/2 t < Z \leq 2 t$			
X	Y	Z										
$\leq a$	Crack can't enter viewing area	$\leq 1/2 t$										
$\leq a$	Crack can't exceed the half of SP width.	$1/2 t < Z \leq 2 t$										

◆ Specification For TFT-LCD Module 3.5" ~15" :

(Ver.B01)

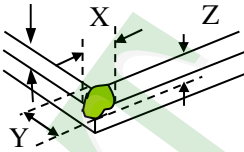
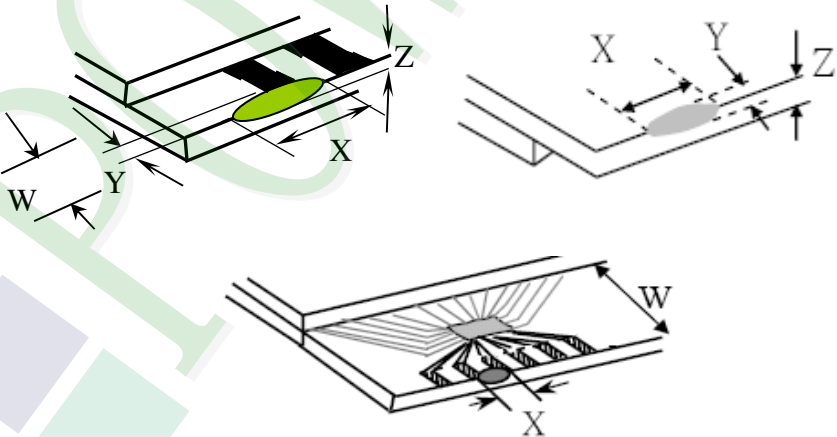
NO	Item	Criterion	Level												
08	The crack of glass	<p>Symbols :</p> <p>X : The length of crack Z : The thickness of crack t : The thickness of glass</p> <p>Y : The width of crack. W : terminal length a : LCD side length</p> <hr/> <p>8.1.2 Corner crack :</p>  <table border="1" data-bbox="523 768 1337 1059"> <thead> <tr> <th>X</th> <th>Y</th> <th>Z</th> </tr> </thead> <tbody> <tr> <td>$\leq 1/5 a$</td> <td>Crack can't enter viewing area</td> <td>$Z \leq 1/2 t$</td> </tr> <tr> <td>$\leq 1/5 a$</td> <td>Crack can't exceed the half of SP width.</td> <td>$1/2 t < Z \leq 2 t$</td> </tr> </tbody> </table>	X	Y	Z	$\leq 1/5 a$	Crack can't enter viewing area	$Z \leq 1/2 t$	$\leq 1/5 a$	Crack can't exceed the half of SP width.	$1/2 t < Z \leq 2 t$				
		X	Y	Z											
$\leq 1/5 a$	Crack can't enter viewing area	$Z \leq 1/2 t$													
$\leq 1/5 a$	Crack can't exceed the half of SP width.	$1/2 t < Z \leq 2 t$													
		<p>8.2 Protrusion over terminal :</p> <p>8.2.1 Chip on electrode pad :</p>  <table border="1" data-bbox="560 1697 1345 1872"> <thead> <tr> <th></th> <th>X</th> <th>Y</th> <th>Z</th> </tr> </thead> <tbody> <tr> <td>Front</td> <td>$\leq a$</td> <td>$\leq 1/2 W$</td> <td>$\leq t$</td> </tr> <tr> <td>Back</td> <td>$\leq a$</td> <td>$\leq W$</td> <td>$\leq 1/2 t$</td> </tr> </tbody> </table>		X	Y	Z	Front	$\leq a$	$\leq 1/2 W$	$\leq t$	Back	$\leq a$	$\leq W$	$\leq 1/2 t$	Minor
	X	Y	Z												
Front	$\leq a$	$\leq 1/2 W$	$\leq t$												
Back	$\leq a$	$\leq W$	$\leq 1/2 t$												

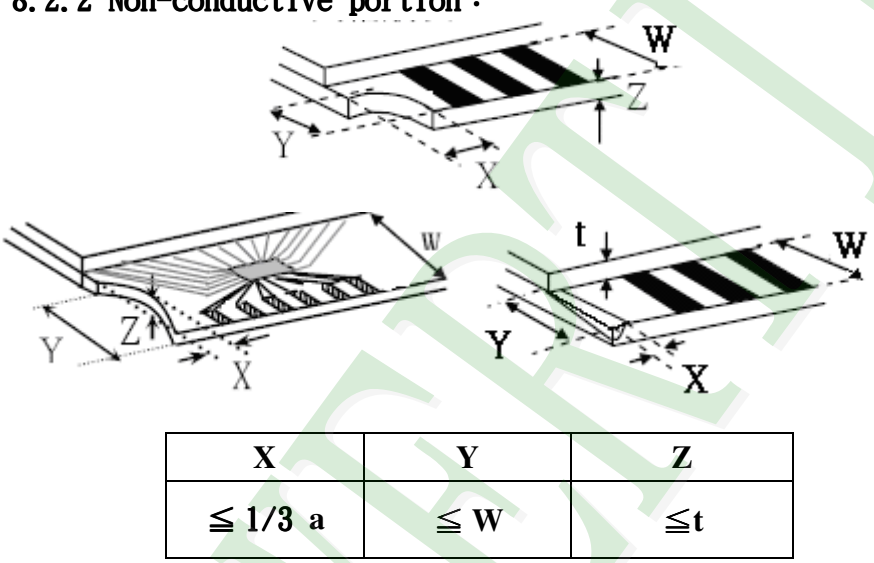
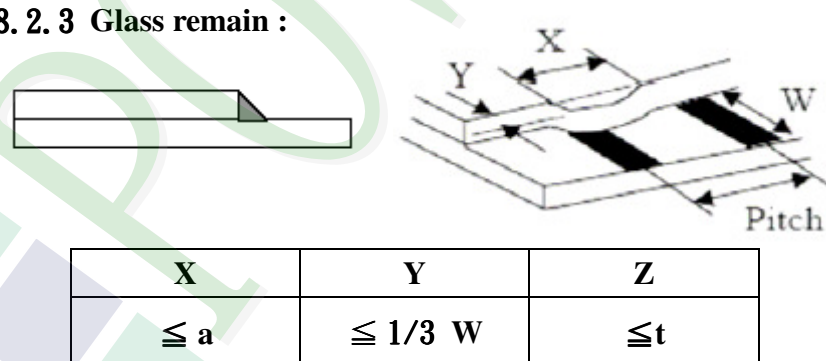
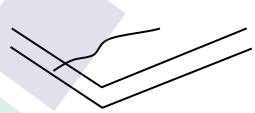
NO	Item	Criterion	Level												
08	The crack of glass	<p>Symbols :</p> <p>X : The length of crack Z : The thickness of crack t : The thickness of glass</p> <p>Y : The width of crack. W : terminal length a : LCD side length</p> <hr/> <p>8.2.2 Non-conductive portion :</p>  <table border="1" style="margin: 10px auto;"> <thead> <tr> <th>X</th> <th>Y</th> <th>Z</th> </tr> </thead> <tbody> <tr> <td style="text-align: center;">$\leq 1/3 a$</td> <td style="text-align: center;">$\leq W$</td> <td style="text-align: center;">$\leq t$</td> </tr> </tbody> </table> <p>⊙ If the chipped area touches the ITO terminal, over 2/3 of</p> <ul style="list-style-type: none"> ● the ITO must remain and be inspected according to electrode terminal specifications. <p>8.2.3 Glass remain :</p>  <table border="1" style="margin: 10px auto;"> <thead> <tr> <th>X</th> <th>Y</th> <th>Z</th> </tr> </thead> <tbody> <tr> <td style="text-align: center;">$\leq a$</td> <td style="text-align: center;">$\leq 1/3 W$</td> <td style="text-align: center;">$\leq t$</td> </tr> </tbody> </table> <p>8.2.4 Cracking</p>  <p style="text-align: center;">Not Allowed</p>	X	Y	Z	$\leq 1/3 a$	$\leq W$	$\leq t$	X	Y	Z	$\leq a$	$\leq 1/3 W$	$\leq t$	Minor
X	Y	Z													
$\leq 1/3 a$	$\leq W$	$\leq t$													
X	Y	Z													
$\leq a$	$\leq 1/3 W$	$\leq t$													

◆Specification For TFT-LCD Module 3.5" ~15" :
(Ver.B01)

NO	Item	Criterion	Level
09	Backlight elements	9. 1 Backlight can't work normally.	Major
		9. 2 Backlight doesn't light or color is wrong.	Major
		9. 3 Illumination source flickers when lit.	Major
10	General appearance	10. 1 Pin type 、 quantity 、 dimension must match type in structure diagram.	Major
		10. 2 No short circuits in components on PCB or FPC .	Major
		10. 3 Parts on PCB or FPC must be the same as on the production characteristic chart .There should be no wrong parts , missing parts or excess parts.	Major
		10. 4 Product packaging must the same as specified on packaging specification sheet.	Minor
		10. 5 The folding and peeled off in polarizer are not acceptable.	Minor
		10. 6 The PCB or FPC between B/L assembled distance(PCB or FPC) is ≤ 1.5 mm.	Minor

5. PRECAUTION RELATING PRODUCT HANDLING

5.1 SAFETY

- 5.1.1 If the LCD panel breaks , be careful not to get the liquid crystal to touch your skin.
- 5.1.2 If the liquid crystal touches your skin or clothes , please wash it off immediately by using soap and water.

5.2 HANDLING

- 5.2.1 Avoid any strong mechanical shock which can break the glass.
- 5.2.2 Avoid static electricity which can damage the CMOS LSI—When working with the module , be sure to ground your body and any electrical equipment you may be using.
- 5.2.3 Do not remove the panel or frame from the module.
- 5.2.4 The polarizing plate of the display is very fragile. So , please handle it very carefully ,do not touch , push or rub the exposed polarizing with anything harder than an HB pencil lead (glass , tweezers , etc.)
- 5.2.5 Do not wipe the polarizing plate with a dry cloth , as it may easily scratch the surface of plate.
- 5.2.6 Do not touch the display area with bare hands , this will stain the display area.
- 5.2.7 Do not use ketonics solvent & aromatic solvent. Use with a soft cloth soaked with a cleaning naphtha solvent.
- 5.2.8 To control temperature and time of soldering is $320\pm 10^{\circ}\text{C}$ and 3-5 sec.
- 5.2.9 To avoid liquid (include organic solvent) stained on LCM .

5.3 STORAGE

- 5.3.1 Store the panel or module in a dark place where the temperature is $25^{\circ}\text{C} \pm 5^{\circ}\text{C}$ and the humidity is below 65% RH.
- 5.3.2 Do not place the module near organics solvents or corrosive gases.
- 5.3.3 Do not crush , shake , or jolt the module.

5.4 TERMS OF WARRANTY

- 5.4.1 Applicable warrant period
The period is within thirteen months since the date of shipping out under normal using and storage conditions.
- 5.4.2 Unaccepted responsibility
This product has been manufactured to your company's specification as a part for use in your company's general electronic products. It is guaranteed to perform according to delivery specifications. For any other use apart from general electronic equipment , we cannot take responsibility if the product is used in nuclear power control equipment , aerospace equipment , fire and security systems or any other applications in which there is a direct risk to human life and where extremely high levels of reliability are required.

LCM包裝規格書

LCM Packaging Specifications

(For Tray)

Approve	Check	Contact
Rex	Tina	Clare

1. 包裝材料規格表 (Packaging Material) : (per carton)

No.	Item	Model	Dimensions (mm)	1Pcs Weight	Quantity	Total Weight
1	成品 (LCD)	PH102600T009-IBC	192.96X110.76X5.54	0.17506	48	8.40288
2	多層薄膜(1)POF	OTFILM0BA03ABA	—————	—————	6	—————
3	TRAY 盤 (2)Tray	TY00000000256	352 X 260 X 16.8	0.1	30	3.0
4	內盒(3)Product Box	BX36627063ABBA	383 X 270 X 66	0.2692	6	1.6152
5	保利龍板(4)Polylon board	OTPLB00PL08ABA	550 X 393 X 20	0.0284	2	0.0568
6	外紙箱(5)Carton	BX57041027CCBA	570 X 410 X 265	1.4208	1	1.4208
7	EPE(6)EPE (註 Remark 5 & 6)	OTFOAMEP0002BA	333 X 218 X 5	0.011	12	0.132
8						
9						

2. 一整箱總重量 (Total LCD Weight in carton) : 14.63 Kg±10%

3. 單箱數量規格表 (Packaging Specifications and Quantity) :

(1)LCD quantity per box : no per tray	2	x no of tray	4	=	8
(2)Total LCD quantity in carton : quantity per box	8	x no of boxes	6	=	48

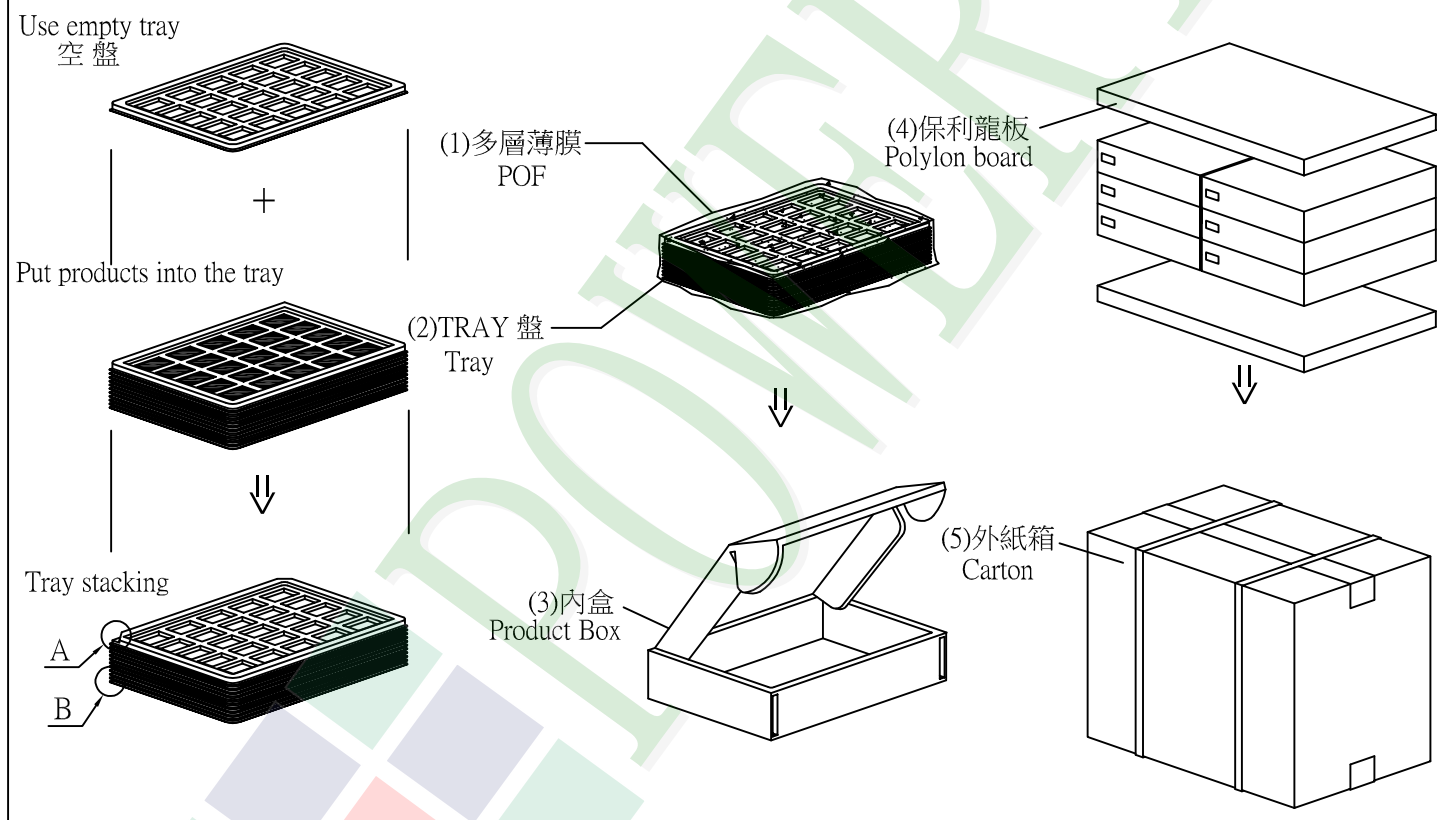

特 記 事 項 (REMARK)

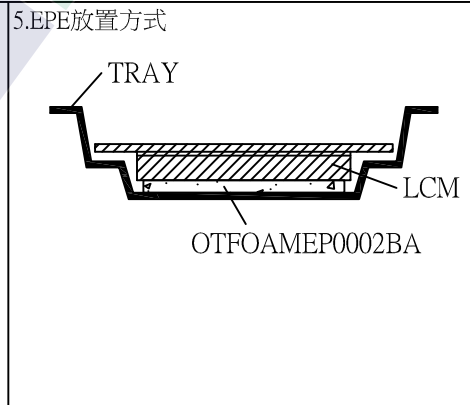
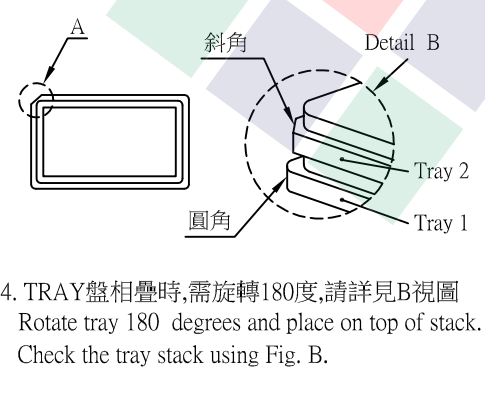

6. OTFOAMEP0002BA 可裁 4 PCS
 尺寸: 155 * 90 mm