

SPECIFICATIONS

CUSTOMER	:	PTC
SAMPLE CODE	:	SH480272T009-IBF01
MASS PRODUCTION CODE	:	PH480272T009-IBF01
SAMPLE VERSION	:	02
SPECIFICATIONS EDITION	:	006
DRAWING NO. (Ver.)	:	JLMD-PH480272T009-IBF01_005
PACKAGING NO. (Ver.)	:	JPKG- PH480272T009-IBF01_002

Customer Approved

Date:

POWERTIP
2016.12.14
JS RD APPROVED

Approved	Checked	Designer
閔偉	劉進	陳璐

- Preliminary specification for design input
- Specification for sample approval

POWERTIP TECH. CORP.

Headquarters: No.8, 6 th Road, Taichung Industrial Park, Taichung, Taiwan 台中市 407 工業區六路 8 號	TEL: 886-4-2355-8168 FAX: 886-4-2355-8166	E-mail: sales@powertip.com.tw Http://www.powertip.com.tw
--	--	---

History of Version

Date	Ver.	Edi.	Description	Page	Design by
03/14/2016	01	001	New Drawing	-	周志仙
03/25/2016	01	002	Modify LCM Drawing	Appendix	周志仙
05/24/2016	01	003	New Sample	-	周志仙
06/28/2016	01	004	Change Touch Panel	9	陳璐
08/31/2016	02	005	Second Sample	-	陳璐
12/05/2016	02	006	Update Packaging Drawing	Appendix	陳璐

Total: 34 Page

Contents

1. SPECIFICATIONS

- 1.1 Features
- 1.2 Mechanical Specifications
- 1.3 Absolute Maximum Ratings
- 1.4 DC Electrical Characteristics
- 1.5 Optical Characteristics
- 1.6 Backlight Characteristics
- 1.7 Touch Panel Characteristics

2. MODULE STRUCTURE

- 2.1 Counter Drawing
- 2.2 Interface Pin Description
- 2.3 Timing Characteristics

3. QUALITY ASSURANCE SYSTEM

- 3.1 Quality Assurance Flow Chart
- 3.2 Inspection Specification

4. RELIABILITY TEST

- 4.1 Reliability Test Condition

5. PRECAUTION RELATING PRODUCT HANDLING

- 5.1 Safety
- 5.2 Handling
- 5.3 Storage
- 5.4 Terms of Warranty

Appendix : 1.LCM Drawing

2.Packaging

Note: For detailed information please refer to IC data sheet:ILITEK--- ILI6480B

1.1 Features

Item	Standard Value
Display Type	480 * 3 (RGB) * 272 Dots
LCD Type	a-Si TFT , Normally White , TN mode , Transmissive type
Screen size(inch)	4.3"(Diagonal)
Viewing Direction	6 O'clock
Color configuration	R,G, B vertical stripe
Display Interface	Digital 24-bits RGB
Driver IC	ILI6480B
ROHS	THIS PRODUCT CONFORMS THE ROHS OF PTC Detail information please refer website : http://www.powertip.com.tw/news.php?area_id_view=1085560481/

1.2 Mechanical Specifications

Item	Standard Value	Unit
Outline Dimension	115.1(W) x 73.9 (L) x 5.525(H)	mm

LCD panel

Item	Standard Value	Unit
Viewing Area	96.7 (W) * 55.3 (L)	mm
Active Area	95.04 (W) x 53.856 (L)	mm
Pixel Size	0.198 (W) * 0.198 (H)	mm

Note : For detailed information please refer to LCM drawing

1.3 Absolute Maximum Ratings

Module

Item	Symbol	Condition	Min.	Max.	Unit
System Power Supply Voltage	VDD	GND=0	-0.5	+5.0	V
Operating Temperature	T _{OP}	-	-20	+70	°C
Storage Temperature	T _{ST}	-	-30	+80	°C
Storage Humidity	H _D	T _a ≤ 60 °C	10	90	%RH

1.4 DC Electrical Characteristics

Module

GND = 0V, T_a = 25°C

Item	Symbol	Condition	Min.	Typ.	Max.	Unit
Power supply	VDD	-	3.0	3.3	3.6	V
	VGH	-	-	15	-	V
	VGL	-	-	-10	-	V
“H” Input Voltage	V _{IH}	-	0.7*VDD	-	VDD	V
“L” Input Voltage	V _{IL}	-	GND	-	0.3* GND	V
“H” Output Voltage	V _{OH}	-	VDD-0.4	-	VDD	V
“L” Output Voltage	V _{OL}	-	GND	-	GND +0.4	V
Supply Current	IDD	VDD=3.3V *1	-	15	25	mA

Note1: Maximum current display.

1.5 Optical Characteristics

TFT LCD Panel

VDD =3.3V, Ta=25°C

Item	Symbol	Condition	Min.	Typ.	Max.	unit		
Response time	Tr + Tf	-	-	30	45	ms	Note2	
Viewing angle	Top	$\theta+$	-	80	-	Deg.	Note4	
	Bottom	$\theta-$	-	80	-			
	Left	θL	-	80	-			
	Right	θR	-	80	-			
Contrast ratio	CR		300	500	-	-	-	
Color of CIE Coordinate (With B/L & TP)	White	X	IF= 20 mA	0.27	0.32	0.37	-	Note1
		Y		0.29	0.34	0.39		
	Red	X		0.52	0.57	0.62		
		Y		0.29	0.34	0.39		
	Green	X		0.29	0.34	0.39		
		Y		0.56	0.61	0.66		
	Blue	X		0.10	0.15	0.20		
		Y		0.03	0.08	0.13		
Average Brightness Pattern=white display (With B/L & TP)	IV	IF= 20 mA	420	460	-	cd/m ²	Note1	
Uniformity	ΔB	IF= 20 mA	70	-	-	%	Note1	

Note1:

1 : $\Delta B = B(\min) / B(\max) \times 100\%$

2 : Measurement Condition for Optical Characteristics:

a : Environment: 25°C±5°C / 60±20%R.H , no wind , dark room below 10 Lux at typical lamp current and typical operating frequency.

b : Measurement Distance: 500 ± 50 mm , ($\theta = 0^\circ$)

c : Equipment: TOPCON BM-7 fast , (field 1°) , after 10 minutes operation.

d : The uncertainty of the C.I.E coordinate measurement ±0.01 , Average Brightness ± 4%

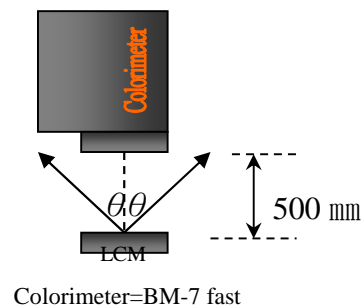
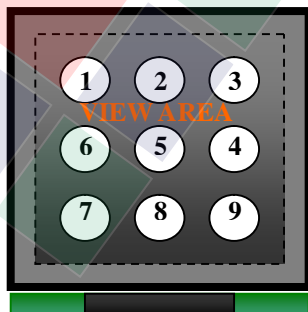

Note2: Definition of response time:

The output signals of photo detector are measured when the input signals are changed from “black” to “white”(falling time) and from “white” to “black”(rising time), respectively. The response time is defined as the time interval between the 10% and 90% of Amplitudes.

Refer to figure as below:

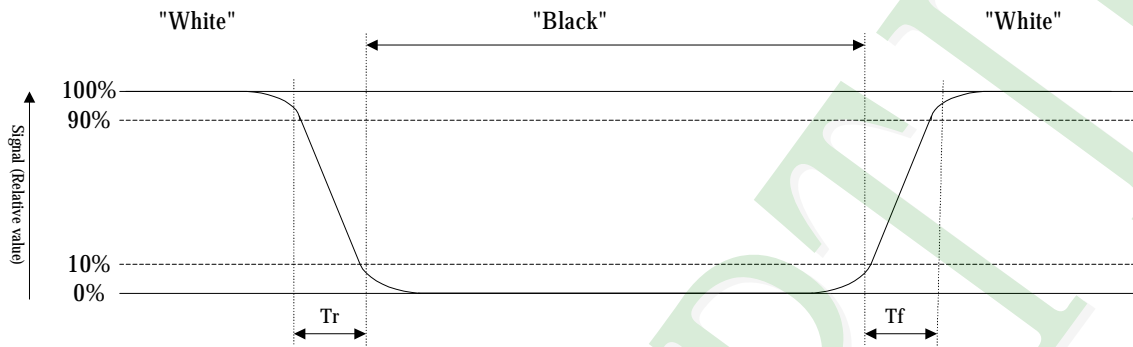

Note3: Definition of contrast ratio:

Contrast ratio is calculated with the following formula

$$\text{Contrast ratio (CR)} = \frac{\text{Photo detector output when LCD is at "White" state}}{\text{Photo detector output when LCD is at "Black" state}}$$

Note4: Definition of viewing angle:

Refer to figure as below:

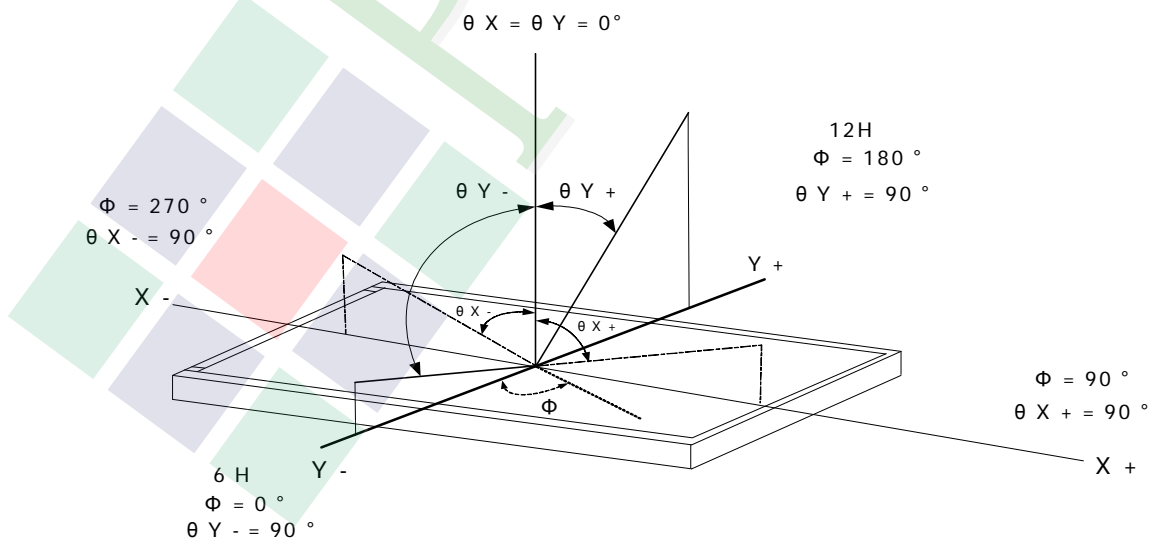

1.6 Backlight Characteristics

Maximum Ratings

Item	Symbol	Conditions	Min.	Max.	Unit
LED Forward Current (Each LED)	IF	Ta =25°C	-	30	mA
LED Reverse Voltage (Each LED)	VR	Ta =25°C	-	5.0	V
Power Dissipation	PD	Ta =25°C	-	90*7	mW

Electrical / Optical Characteristics

Item	Symbol	Conditions	Min.	Typ.	Max.	Unit
Forward Voltage	VF	IF=20mA	18.2	22.8	24.5	V
Average Brightness (Without LCD)	IV		6000	7200	9600	cd/m ²
CIE Color Coordinate (Without LCD)	X		0.26	0.30	0.33	-
	Y		0.26	0.30	0.33	
Color	White					

Internal Circuit Diagram



Other Description

Item	Conditions	Description
Life Time	Ta =25°C IF= 20mA	20000 hrs

1.7 Touch Panel Characteristics

Features

Item	Standard Value
Touch Panel Size	4.3"
Touch type	Projective capacitive touch panel True Multi-touch with up to 5 Points of Absolution
Output Interface	I ² C
IC	FT5426

Mechanical Specifications

Item	Standard Value	Unit
Viewing Area	97.10 mm (W) x 55.90 mm (H)	mm
Number of sensing channel	-	mm

Absolute Maximum Ratings

Item	Symbol	Condition	Min.	Max.	Unit
Operating Temperature	T _{OP}	-	-20	+70	°C
Storage Temperature	T _{ST}	-	-30	+80	°C

DC Electrical Characteristics

Item	Symbol	Condition	Min.	Typ.	Max.	Unit
Power Supply Voltage	VDD	-	2.8	3.3	3.6	V

Optical Characteristics

Item	Standard Value	Unit
Total light transmittance	85% or more	-
Haze	3% or less	-

PIN Definition

Pin No.	Symbol	Function
1	GND	Ground
2	SDA	I ² C Data
3	SCL	I ² C Clock

4	VDD	Digital I/O Power Can be Set as VDD
5	INT	Interrupt Output
6	nRST	Chip Reset Input, Negative Edge Trigger

I²C Read/Write Interface description

Write N bytes to I2C slave

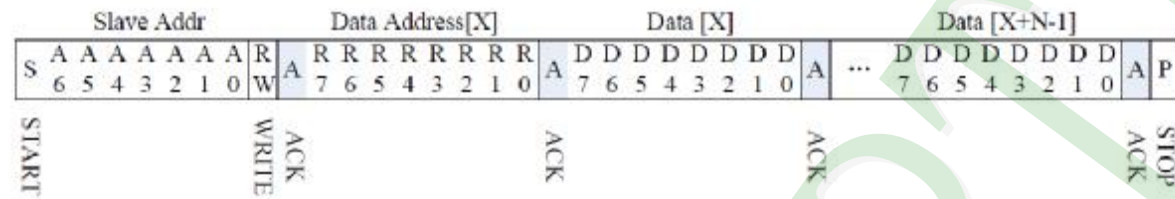

Set Data Address

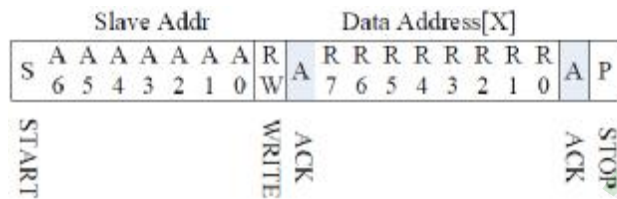

Read X bytes from I2C Slave

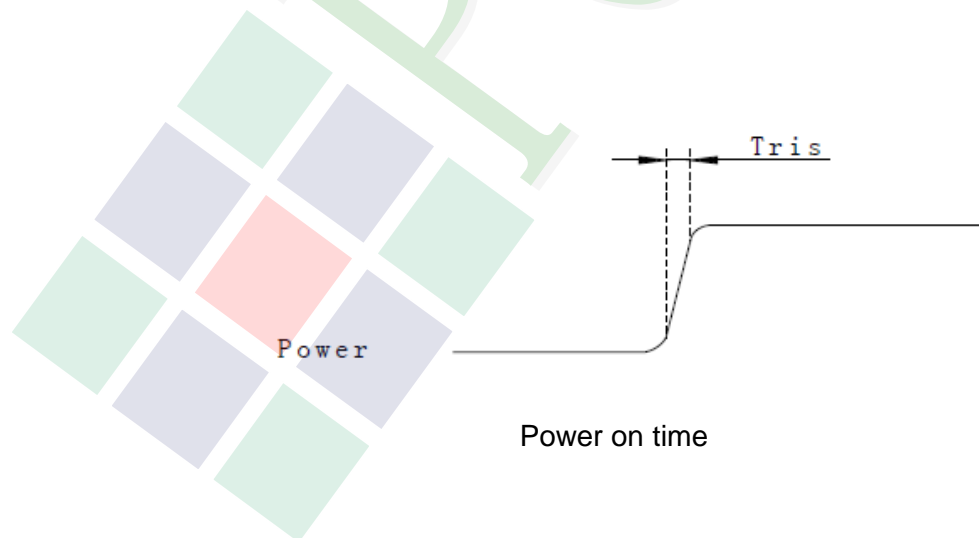

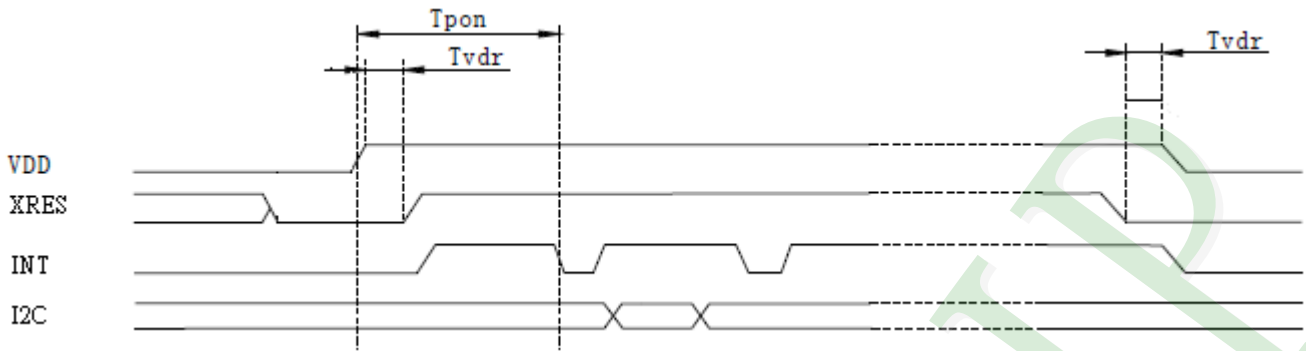

Power on Sequence

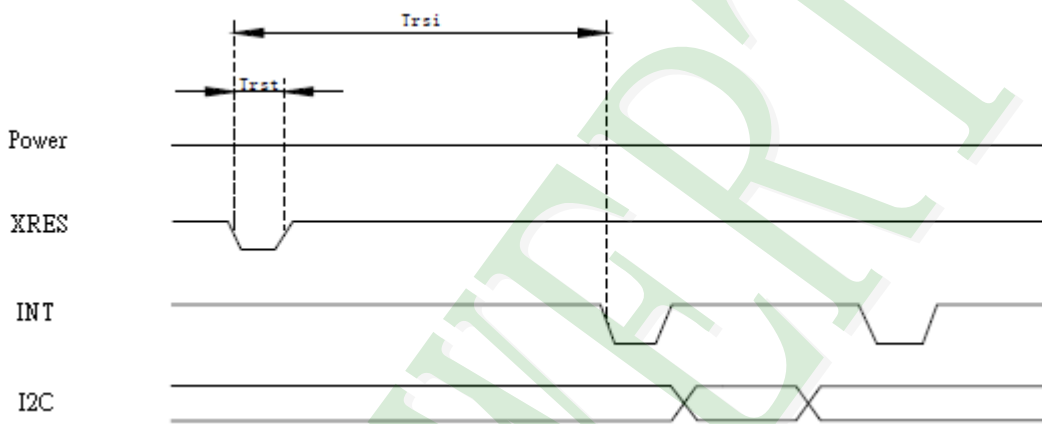

Reset Sequence

Power on / Reset Sequence Parameters

Parameter	Description	Min	Max	Units
Tris	Rise time from 0.1VDD to 0.9VDD	--	5	ms
Tpon	Time of starting to report point after powering on	200	--	ms
Tvdr	Reset time after VDD powering on	1	--	ms
Trsi	Time of starting to report point after resetting	200	--	ms
Trst	Reset time	1	--	ms

Interrupt signal from CTP to Host

As for standard CTP, host need to use both interrupt control signal and serial data interface to get the touch data. There are two kind of method to use interrupt: interrupt trigger and interrupt query.

Here is the timing to get touch data.

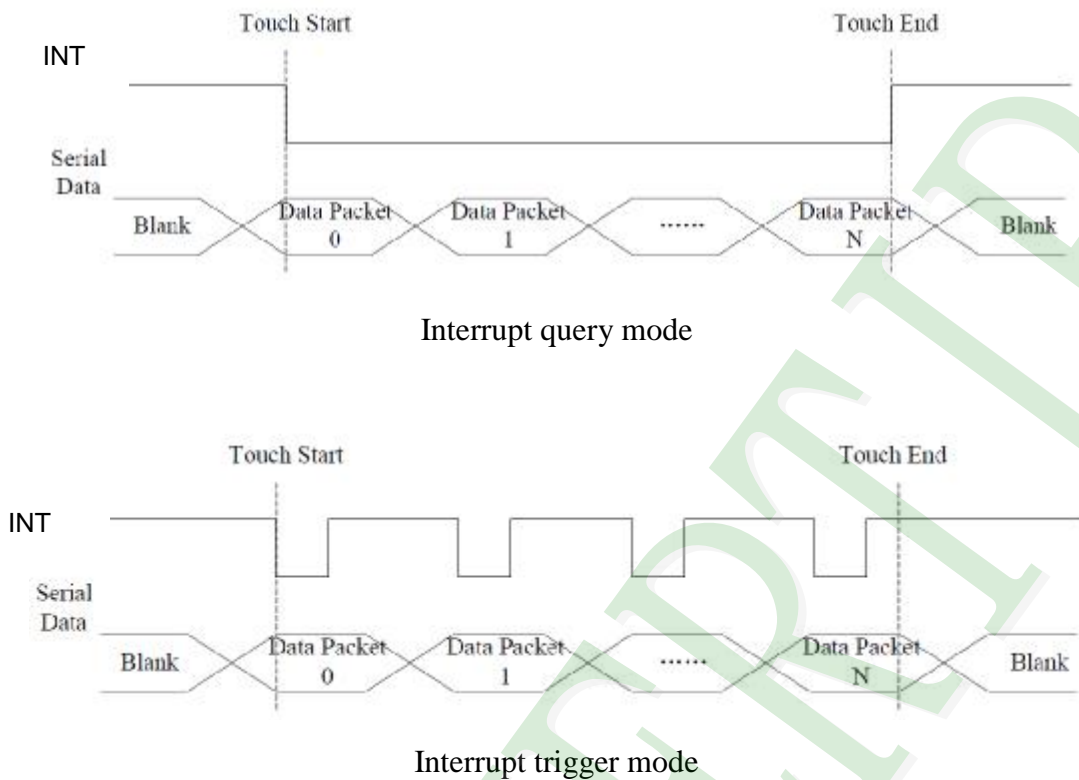

Host use general I2C protocol to read the touch data or the information from CTP . CTP will send host a interrupt signal when there is a valid touch. Then host can use the serial data interface to get the touch data. If there is no valid touch detected, the INT will not be pulled up, the host do not need to read the touch data.

NOTE: “valid touch” may have different definition in various systems. For example, in some systems, the valid touch is defined as there is one more valid touch point. But in some other systems, the valid touch is defined as one more valid touch with valid gestures. In usual, INT will be pulled up when there is a valid touch point, and to be low when a touch finishes.

As for interrupt trigger mode, INT signal will be low if there is a touch detected. But for per update of valid touch data, CTP will produce a valid pulse for INT signal, host can read the touch data periodically according to the frequency of this pulse. In this mode, the pulse frequency is the touch data update frequency.

CTP Register Mapping

Address	Name	Bit7	Bit6	Bit5	Bit4	Bit3	Bit2	Bit1	Bit0	Host Access
Op,00h	DEVIDE_MODE		Device Mode[2:0]							RW
Op,01h	GEST_ID	Gesture ID[7:0]								R
Op,02h	TD_STATUS					Number of touch points[3:0]				R
Op,03h	TOUCH1_XH	1 st Event Flag				1 st Touch X Position[11:8]				R
Op,04h	TOUCH1_XL	1 st Touch X Position[7:0]								R
Op,05h	TOUCH1_YH	1 st Touch ID[3:0]				1 st Touch Y Position[11:8]				R
Op,06h	TOUCH1_YL	1 st Touch Y Position[7:0]								R
Op,07h	Reserved									
Op,08h	Reserved									
Op,09h	TOUCH2_XH	2 nd Event Flag				2 nd touch X Position[11:8]				R
Op,0Ah	TOUCH2_XL	2 nd touch X Position[7:0]								R
Op,0Bh	TOUCH2_YH	2 nd Touch ID[3:0]				2 nd Touch Y Position[11:8]				R
Op,0Ch	TOUCH2_YL	2 nd Touch Y Position[7:0]								R
Op,0Dh	Reserved									
Op,0Eh	Reserved									
Op,0Fh	TOUCH3_XH	3 rd Event Flag				3 rd Touch X Position[11:8]				R
Op,10h	TOUCH3_XL	3 rd Touch X Position[7:0]								R
Op,11h	TOUCH3_YH	3 rd Touch ID[3:0]				3 rd Touch Y Position[11:8]				R
Op,12h	TOUCH3_YL	3 rd Touch Y Position[7:0]								R
Op,13h	Reserved									
Op,14h	Reserved									
Op,15h	TOUCH4_XH	4 th Event Flag				4 th Touch X Position[11:8]				R
Op,16h	TOUCH4_XL	4 th Touch X Position[7:0]								R
Op,17h	TOUCH4_YH	4 th Touch ID[3:0]				4 th Touch Y Position[11:8]				R
Op,18h	TOUCH4_YL	4 th Touch Y Position[7:0]								R
Op,19h	Reserved									
Op,1Ah	Reserved									

Op,1Bh	TOUCH5_XH	5 th Event Flag		5 th Touch X Position[11:8]	R
Op,1Ch	TOUCH5_XL	5 th Touch X Position[7:0]			R
Op,1Dh	TOUCH5_YH	5 th Touch ID[3:0]		5 th Touch Y Position[11:8]	R
Op,1Eh	TOUCH5_YL	5 th Touch Y Position[7:0]			R
Op,1Fh	Reserved				
Op,20h	Reserved				
Op,21h	TOUCH6_XH	6 th Event Flag		6 th Touch X Position[11:8]	R
Op,22h	TOUCH6_XL	6 th Touch X Position[7:0]			R
Op,23h	TOUCH6_YH	6 th Touch ID[3:0]		6 th Touch Y Position[11:8]	R
Op,24h	TOUCH6_YL	6 th Touch Y Position[7:0]			R
Op,25h	Reserved				
Op,26h	Reserved				
Op,27h	TOUCH7_XH	7 th Event Flag		7 th Touch X Position[11:8]	R
Op,28h	TOUCH7_XL	7 th Touch X Position[7:0]			R
Op,29h	TOUCH7_YH	7 th Touch ID[3:0]		7 th Touch Y Position[11:8]	R
Op,2Ah	TOUCH7_YL	7 th Touch Y Position[7:0]			R
Op,2Bh	Reserved				
Op,2Ch	Reserved				
Op,2Dh	TOUCH8_XH	8 th Event Flag		8 th Touch X Position[11:8]	R
Op,2Eh	TOUCH8_XL	8 th Touch X Position[7:0]			R
Op,2Fh	TOUCH8_YH	8 th Touch ID[3:0]		8 th Touch Y Position[11:8]	R
Op,30h	TOUCH8_YL	8 th Touch Y Position[7:0]			R
Op,31h	Reserved				
Op,32h	Reserved				
Op,33h	TOUCH9_XH	9 th Event Flag		9 th Touch X Position[11:8]	R
Op,34h	TOUCH9_XL	9 th Touch X Position[7:0]			R
Op,35h	TOUCH9_YH	9 th Touch ID[3:0]		9 th Touch Y Position[11:8]	R
Op,36h	TOUCH9_YL	9 th Touch Y Position[7:0]			R
Op,37h	Reserved				
Op,38h	Reserved				
Op,39h	TOUCH10_XH	10 th Event Flag		10 th Touch X Position[11:8]	R
Op,3Ah	TOUCH10_XL	10 th Touch X Position[7:0]			R
Op,3Bh	TOUCH10_YH	10 th Touch ID[3:0]		10 th Touch Y Position[11:8]	R

Op,3Ch	TOUCH10_YL	10 st Touch Y Position[7:0]	R
Op,3Dh	Reserved		
Op,3Eh	Reserved		
...
Op,FEh	LOG_MSG_CNT	The log MSG count	R
Op,FFh	LOG_CUR_CHA	Current character of log message, will point to the next character when one character is read.	R

DEVICE_MODE

This register is the device mode register, user the get current the device mode.

Bit Address	Register Name	Description
6:4	Device Mode[2:0]	000b Normal operating Mode 001b System Information Mode (Reserved) 100b Test Mode – read raw data (Reserved)

GEST_ID

This register describes the gesture of a valid touch.

Bit Address	Register Name	Description
7:0	Gesture ID[7:0]	Gesture ID 0x10 Single Touch Pan North 0x14 Single Touch Pan East 0x18 Single Touch Pan South 0x1C Single Touch Pan West 0x20 Single Touch Single Click 0x22 Single Touch Double Click 0x28 Single Touch Rotate Clockwise 0x29 Single Touch rotate Counter Clockwise 0x40 Zoom In 0x49 Zoom Out

TD_STATUS

This register is the Touch Data status register.

Bit Address	Register Name	Description
3:0	Number of touch points[3:0]	How many points detected. 1-5 is valid.

TOUCHn_XH (n:1-10)

This register describes MSB of the X coordinate of the nth touch point and the corresponding event flag.

Bit Address	Register Name	Description
7:6	Event Flag	00b: Put Down 01b: Put Up 10b: Contact 11b: Reserved
5:4		Reserved
3:0	Touch X Position[11:8]	MSB of Touch X Position in pixels

TOUCHn_XL (n:1-10)

This register describes LSB of the X coordinate of the nth touch point.

Bit Address	Register Name	Description
7:0	Touch X Position[7:0]	LSB of the Touch X Position in pixels

TOUCHn_YH (n:1-10)

This register describes MSB of the Y coordinate of the nth touch point and corresponding touch ID.

Bit Address	Register Name	Description
7:4	Touch ID[3:0]	Touch ID of Touch Point
3:0	Touch X Position[11:8]	MSB of Touch Y Position in pixels

TOUCHn_YL (n:1-10)

This register describes LSB of the Y coordinate of the nth touch point.

Bit Address	Register Name	Description
7:0	Touch X Position[7:0]	LSB of The Touch Y Position in pixels

2. MODULE STRUCTURE

2.1 Counter Drawing

2.1.1 LCM Mechanical Diagram

* See Appendix

2.1.2 Block Diagram

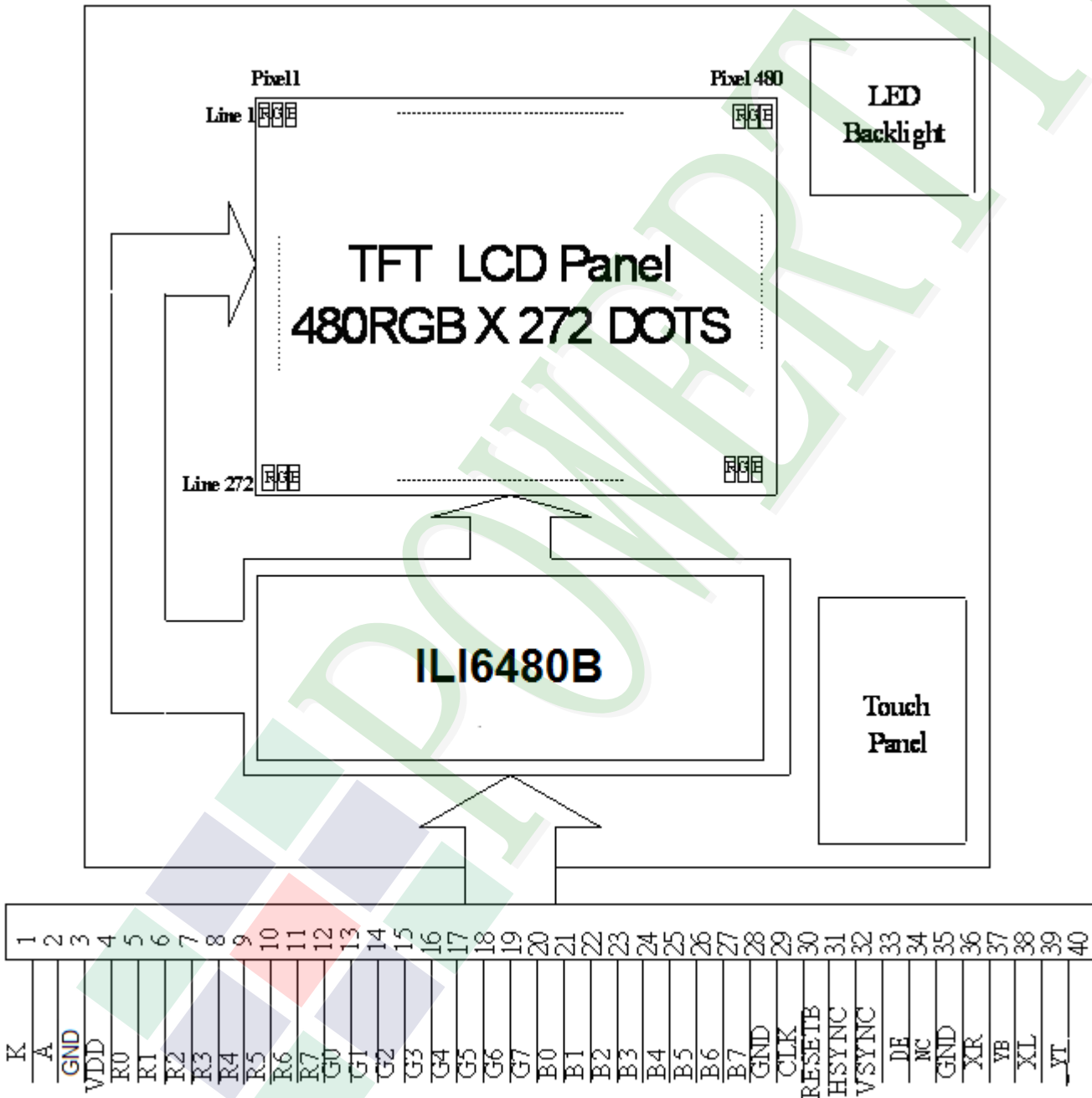

2.2 Interface Pin Description

Pin No.	Symbol	Function
1	K	Power supply for LED Backlight cathode input
2	A	Power supply for LED Backlight anode input
3	GND	Ground
4	VDD	Digital power
5	R0	Red data bit 0
6	R1	Red data bit 1
7	R2	Red data bit 2
8	R3	Red data bit 3
9	R4	Red data bit 4
10	R5	Red data bit 5
11	R6	Red data bit 6
12	R7	Red data bit 7
13	G0	Green data bit 0
14	G1	Green data bit 1
15	G2	Green data bit 2
16	G3	Green data bit 3
17	G4	Green data bit 4
18	G5	Green data bit 5
19	G6	Green data bit 6
20	G7	Green data bit 7

Pin No.	Symbol	Function
21	B0	Blue data bit 0
22	B1	Blue data bit 1
23	B2	Blue data bit 2
24	B3	Blue data bit 3
25	B4	Blue data bit 4
26	B5	Blue data bit 5
27	B6	Blue data bit 6
28	B7	Blue data bit 7
29	GND	Ground
30	CLK	Dot data clock
31	DISP	Display control / standby mode selection "High" : Normal display
32	HSYNC	Horizontal sync input
33	VSYNC	Vertical sync input
34	DE	Data input enable. Active High to enable the data input
35	N.C	Not Connect.
36	GND	Ground
37	XR	Not Connect.
38	YB	Not Connect.
39	XL	Not Connect.
40	YT	Not Connect.

2.3 Timing Characteristics

2.3.1 Clock and Data Input Waveforms

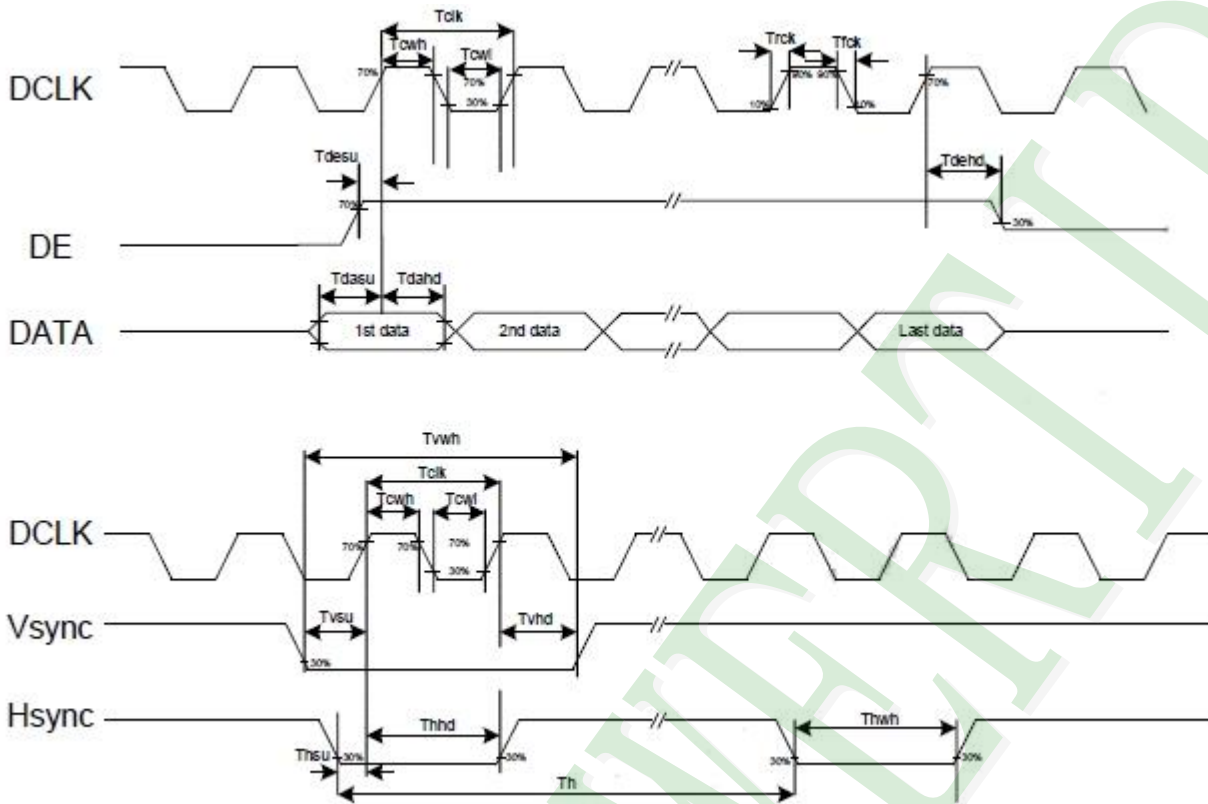

Parameters	Symbol	Min.	Typ.	Max.	Unit	Conditions
System operation timing						
VDD power source slew time	TPOR	-	-	20	ms	From 0V to 99% VDD
GRB pulse width	tRSTW	10	50	-	us	R=10Kohm, C=1uF
Input Output timing						
DCLK clock time	Tclk	33.3	-	-	ns	DCLK=30MHz
DCLK clock low period	Tcwl	40	-	60	%	
DCLK clock high period	Tcwh	40	-	60	%	
Clock rising time	Trck	9	-	-	ns	
Clock falling time	Tfck	9	-	-	ns	
HSD width	Thwh	1	-	-	DCLK	
HSD period time	Th	55	60	65	us	
HSD setup time	Thsu	12	-	-	ns	
HSD hold time	Thhd	12	-	-	ns	
VSD width	Twvh	1	-	-	Th	
VSD setup time	Tvsu	12	-	-	ns	
VSD hold time	Tvhd	12	-	-	ns	
Data setup time	Tdasu	12	-	-	ns	
Data hold time	Tdahd	12	-	-	ns	
DE setup time	Tdesu	12	-	-	ns	
DE hold time	Tdehd	12	-	-	ns	
Source output setting time	Tsst	-	-	TBD	us	10% to 90% CL=60pF, RL=2Kohm
Gate output setting time	Tgst	-	-	1200	ns	10% to 90%, CL=60pF
VCOM output setting time	Tcst	-	-	TBD	us	10% to 90%, CL=40nF, RL=50ohm
Time from VSD to 1st line data input	Tvs	3	8	31	Th	HV mode By HDL[4:0] setting

2.3.2 Data Input Format

Vertical input timing

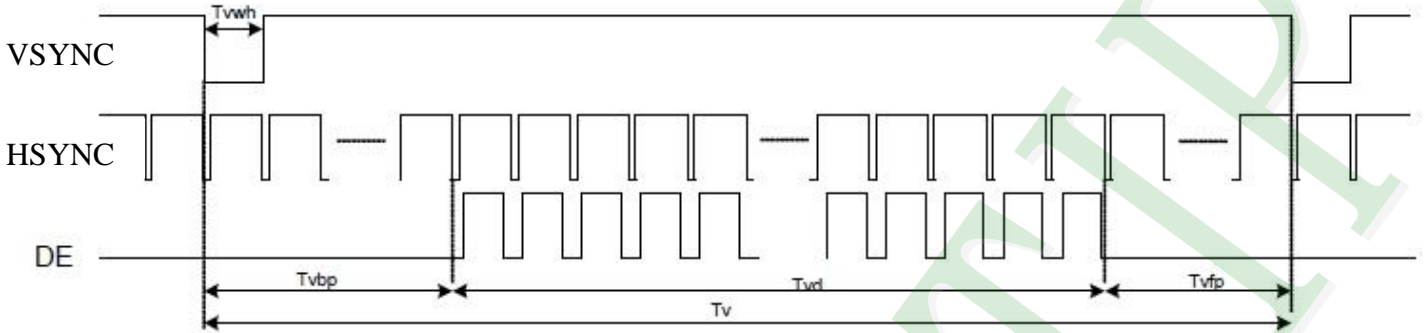

Parallel RGB Mode Data format

(HV Mode)



(DE Mode)

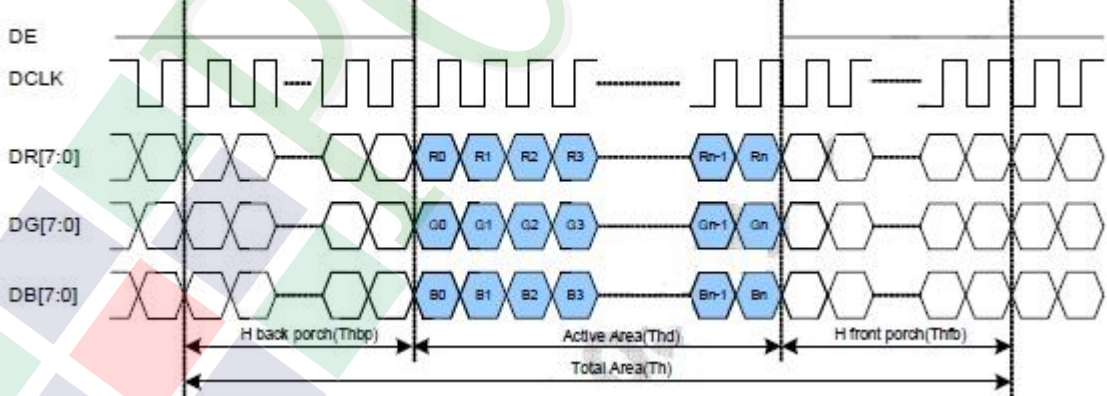

Parallel RGB input timign table

Parameters	Symbol	Value			Unit
		Min.	Typ.	Max.	
DCLK frequency	Fclk	5	9	12	MHz
VSYNC period time	Tv	277	288	400	H
VSYNC display area	Tvd	272			H
VSYNC back porch	Tvb	3	8	31	H
VSYNC front porch	Tvfp	2	8	97	H
HSYNC period time	Th	520	525	800	DCLK
HSYNC display area	Thd	480			DCLK
HSYNC back porch	Thbp	36	40	255	DCLK
HSYNC front porch	Thfp	4	5	65	DCLK

3. QUALITY ASSURANCE SYSTEM

3.1 Quality Assurance Flow Chart

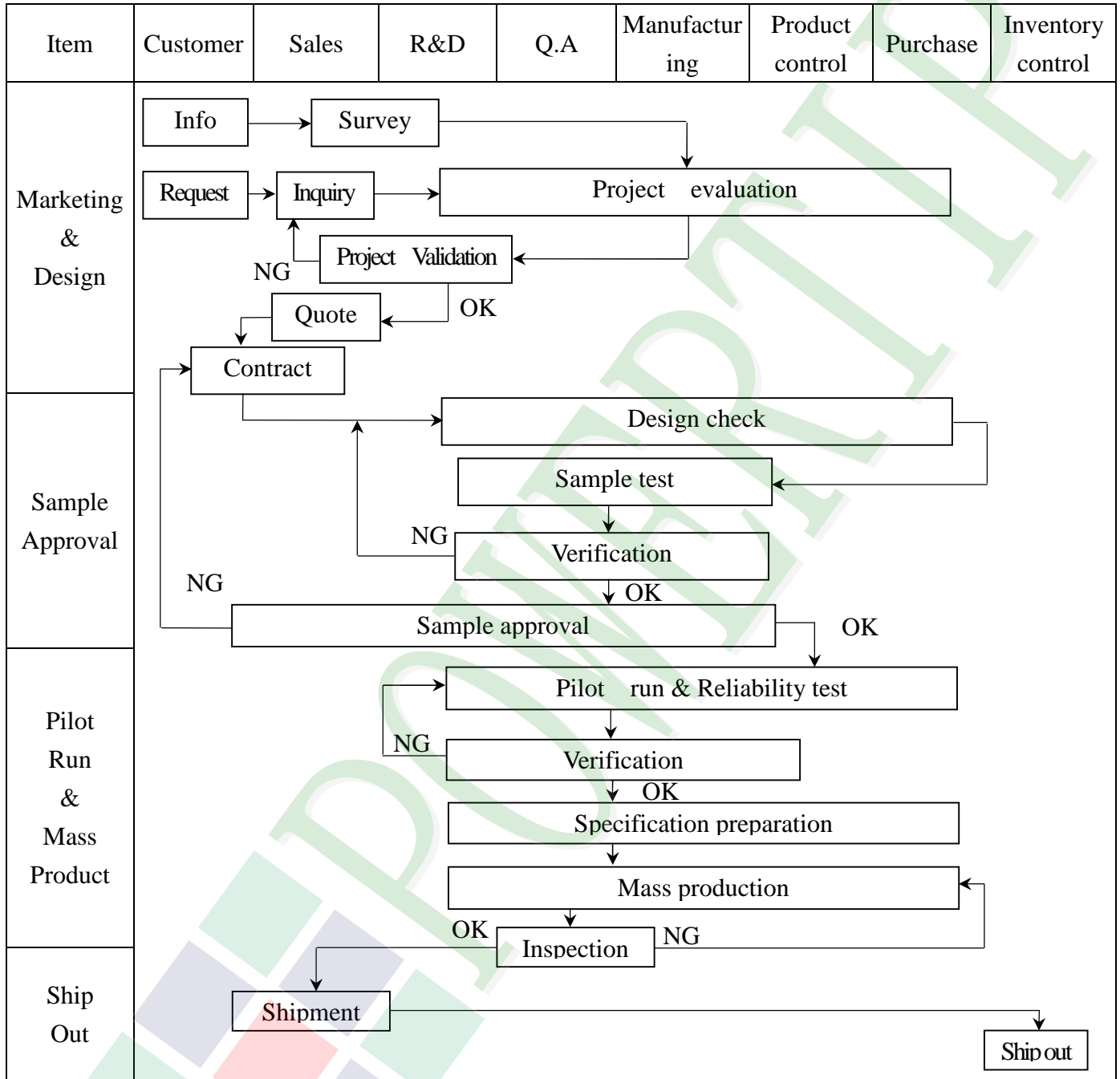

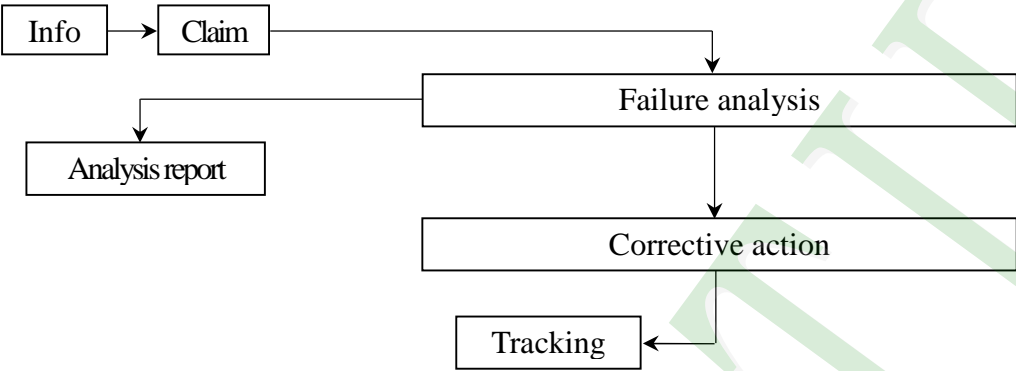
Item	Customer	Sales	R&D	Q.A	Manufacturing	Product control	Purchase	Inventory control
Sales Service	 <pre> graph TD Info[Info] --> Claim[Claim] Claim --> Failure[Failure analysis] Failure --> Report[Analysis report] Failure --> Action[Corrective action] Action --> Tracking[Tracking] </pre>							
Q.A Activity	1. ISO 9001 Maintenance Activities 3. Equipment calibration 5. Standardization Management				2. Process improvement proposal 4. Education And Training Activities			

3.2. Inspection Specification

- ◆Scope : The document shall be applied to TFT-LCD Module for 3.5" ~10" (Ver.B01).
- ◆Inspection Standard : MIL-STD-105E Table Normal Inspection Single Sampling Level II.
- ◆Equipment : Gauge 、 MIL-STD 、 Powertip Tester 、 Sample
- ◆Defect Level : Major Defect AQL : 0.4 ; Minor Defect AQL : 1.5
- ◆OUT Going Defect Level : Sampling.
- ◆Standard of the product appearance test :

a. Manner of appearance test :

- (1). The test best be under 20W×2 fluorescent light , and distance of view must be at 30 cm.
- (2). The test direction is base on about around 45° of vertical line.

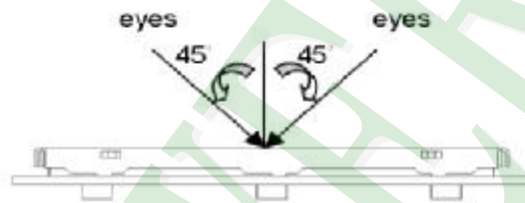

(3). Definition of area.

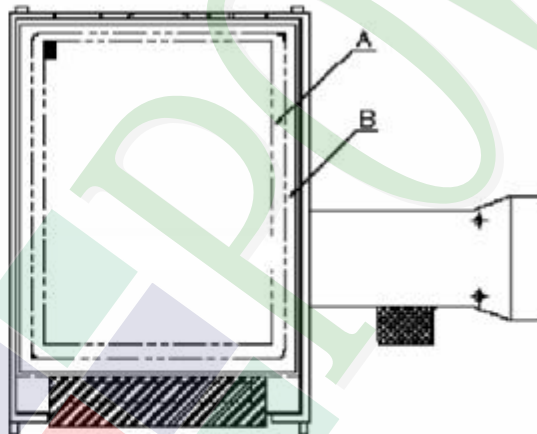

A area : viewing area

B area : Outside of viewing area

(4). Standard of inspection : (Unit : mm)

◆ Specification For TFT-LCD Module 3.5" ~10" :

(Ver.B01)

NO	Item	Criterion	Level										
01	Product condition	1. 1 The part number is inconsistent with work order of production.	Major										
		1. 2 Mixed product types.	Major										
		1. 3 Assembled in inverse direction.	Major										
02	Quantity	2. 1 The quantity is inconsistent with work order of production.	Major										
03	Outline dimension	3. 1 Product dimension and structure must conform to structure diagram.	Major										
		4. 1 Missing line character and icon.	Major										
04	Electrical Testing	4. 2 No function or no display.	Major										
		4. 3 Display malfunction.	Major										
		4. 4 LCD viewing angle defect.	Major										
		4. 5 Current consumption exceeds product specifications.	Major										
05	Dot defect (Bright dot , Dark dot) On -display	<table border="1"> <thead> <tr> <th>Item</th> <th>Acceptance (Q'ty)</th> </tr> </thead> <tbody> <tr> <td>Bright Dot</td> <td>≤ 4</td> </tr> <tr> <td>Dark Dot</td> <td>≤ 5</td> </tr> <tr> <td>Joint Dot</td> <td>≤ 3</td> </tr> <tr> <td>Total</td> <td>≤ 7</td> </tr> </tbody> </table>	Item	Acceptance (Q'ty)	Bright Dot	≤ 4	Dark Dot	≤ 5	Joint Dot	≤ 3	Total	≤ 7	Minor
		Item	Acceptance (Q'ty)										
		Bright Dot	≤ 4										
		Dark Dot	≤ 5										
		Joint Dot	≤ 3										
Total	≤ 7												
5. 1 Inspection pattern : full white , full black , Red , Green and blue screens.													
5. 2 It is defined as dot defect if defect area $> 1/2$ dot.													
5. 3 The distance between two dot defect ≥ 5 mm.													

◆ Specification For TFT-LCD Module 3.5" ~10" :

(Ver.B01)

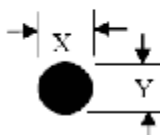
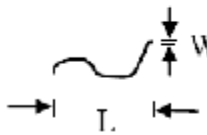
NO	Item	Level																																								
06	<p style="text-align: center;">6.1 Round type (Non-display or display) :</p> <div style="display: flex; justify-content: space-between;"> <div style="width: 30%;"> <p>Black or white dot , scratch , contamination</p> <p>Round type</p>  <p>$\Phi = (x + y) / 2$</p> <p>Line type</p>  </div> <div style="width: 60%;"> <table border="1" style="margin-bottom: 20px;"> <thead> <tr> <th rowspan="2">Dimension (diameter : Φ)</th> <th colspan="2">Acceptance (Q'ty)</th> </tr> <tr> <th>A area</th> <th>B area</th> </tr> </thead> <tbody> <tr> <td>$\Phi \leq 0.25$</td> <td colspan="2">Ignore</td> </tr> <tr> <td>$0.25 < \Phi \leq 0.50$</td> <td>5</td> <td rowspan="3">Ignore</td> </tr> <tr> <td>$\Phi > 0.50$</td> <td>0</td> </tr> <tr> <td>Total</td> <td>5</td> </tr> </tbody> </table> <p style="text-align: center;">6.2 Line type(Non-display or display) :</p> <table border="1"> <thead> <tr> <th rowspan="2">Length (L)</th> <th rowspan="2">Width (W)</th> <th colspan="2">Acceptance (Q'ty)</th> </tr> <tr> <th>A area</th> <th>B area</th> </tr> </thead> <tbody> <tr> <td>---</td> <td>$W \leq 0.03$</td> <td colspan="2">Ignore</td> </tr> <tr> <td>$L \leq 10.0$</td> <td>$0.03 < W \leq 0.05$</td> <td>4</td> <td rowspan="3">Ignore</td> </tr> <tr> <td>$L \leq 5.0$</td> <td>$0.05 < W \leq 0.10$</td> <td>2</td> </tr> <tr> <td>---</td> <td>$W > 0.10$</td> <td colspan="2">As round type</td> </tr> <tr> <td>Total</td> <td></td> <td colspan="2">5</td> </tr> </tbody> </table> </div> </div>	Dimension (diameter : Φ)	Acceptance (Q'ty)		A area	B area	$\Phi \leq 0.25$	Ignore		$0.25 < \Phi \leq 0.50$	5	Ignore	$\Phi > 0.50$	0	Total	5	Length (L)	Width (W)	Acceptance (Q'ty)		A area	B area	---	$W \leq 0.03$	Ignore		$L \leq 10.0$	$0.03 < W \leq 0.05$	4	Ignore	$L \leq 5.0$	$0.05 < W \leq 0.10$	2	---	$W > 0.10$	As round type		Total		5		Minor
Dimension (diameter : Φ)	Acceptance (Q'ty)																																									
	A area	B area																																								
$\Phi \leq 0.25$	Ignore																																									
$0.25 < \Phi \leq 0.50$	5	Ignore																																								
$\Phi > 0.50$	0																																									
Total	5																																									
Length (L)	Width (W)	Acceptance (Q'ty)																																								
		A area	B area																																							
---	$W \leq 0.03$	Ignore																																								
$L \leq 10.0$	$0.03 < W \leq 0.05$	4	Ignore																																							
$L \leq 5.0$	$0.05 < W \leq 0.10$	2																																								
---	$W > 0.10$	As round type																																								
Total		5																																								
07	<p>Polarizer Bubble</p> <table border="1" style="margin-left: auto; margin-right: auto;"> <thead> <tr> <th rowspan="2">Dimension (diameter : Φ)</th> <th colspan="2">Acceptance (Q'ty)</th> </tr> <tr> <th>A area</th> <th>B area</th> </tr> </thead> <tbody> <tr> <td>$\Phi \leq 0.25$</td> <td colspan="2">Ignore</td> </tr> <tr> <td>$0.25 < \Phi \leq 0.50$</td> <td>4</td> <td rowspan="3">Ignore</td> </tr> <tr> <td>$0.50 < \Phi \leq 0.80$</td> <td>1</td> </tr> <tr> <td>$\Phi > 0.80$</td> <td>0</td> </tr> <tr> <td>Total</td> <td colspan="2">5</td> </tr> </tbody> </table>	Dimension (diameter : Φ)	Acceptance (Q'ty)		A area	B area	$\Phi \leq 0.25$	Ignore		$0.25 < \Phi \leq 0.50$	4	Ignore	$0.50 < \Phi \leq 0.80$	1	$\Phi > 0.80$	0	Total	5		Minor																						
Dimension (diameter : Φ)	Acceptance (Q'ty)																																									
	A area	B area																																								
$\Phi \leq 0.25$	Ignore																																									
$0.25 < \Phi \leq 0.50$	4	Ignore																																								
$0.50 < \Phi \leq 0.80$	1																																									
$\Phi > 0.80$	0																																									
Total	5																																									

◆Specification For TFT-LCD Module 3.5" ~10" :

(Ver.B01)

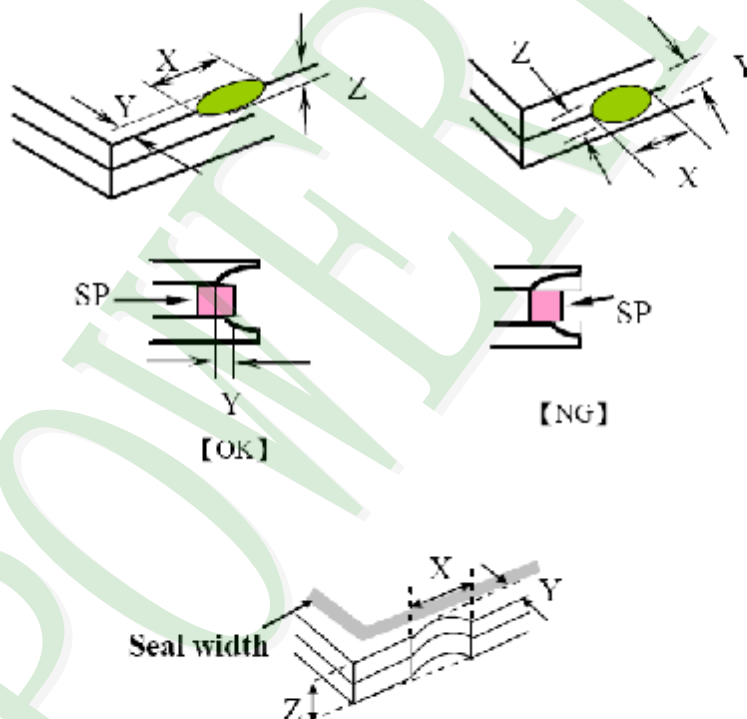
NO	Item	Criterion	Level						
08	The crack of glass	Symbols : X : The length of crack Z : The thickness of crack t : The thickness of glass Y : The width of crack. W : terminal length a : LCD side length	Minor						
		<p>8.1 General glass chip :</p> <p>8.1.1 Chip on panel surface and crack between panels:</p>  <table border="1" data-bbox="542 1568 1340 1859"> <thead> <tr> <th>X</th> <th>Y</th> <th>Z</th> </tr> </thead> <tbody> <tr> <td>$\leq a$</td> <td>Crack can't enter viewing area</td> <td>$\leq 1/2 t$</td> </tr> <tr> <td>$\leq a$</td> <td>Crack can't exceed the half of SP width.</td> <td>$1/2 t < Z \leq 2 t$</td> </tr> </tbody> </table>		X	Y	Z	$\leq a$	Crack can't enter viewing area	$\leq 1/2 t$
X	Y	Z							
$\leq a$	Crack can't enter viewing area	$\leq 1/2 t$							
$\leq a$	Crack can't exceed the half of SP width.	$1/2 t < Z \leq 2 t$							

◆ Specification For TFT-LCD Module 3.5" ~10" :

(Ver.B01)

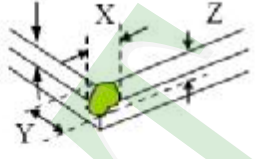
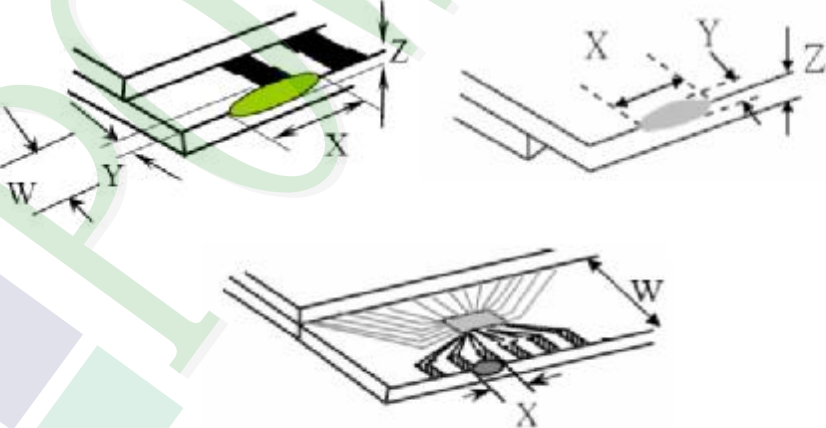
NO	Item	Criterion	Level												
08	The crack of glass	<p>Symbols :</p> <p>X : The length of crack Z : The thickness of crack t : The thickness of glass</p> <p>Y : The width of crack. W : terminal length a : LCD side length</p> <hr/> <p>8.1.2 Corner crack :</p>  <table border="1" data-bbox="523 772 1332 1064"> <thead> <tr> <th>X</th> <th>Y</th> <th>Z</th> </tr> </thead> <tbody> <tr> <td>$\leq 1/5 a$</td> <td>Crack can't enter viewing area</td> <td>$Z \leq 1/2 t$</td> </tr> <tr> <td>$\leq 1/5 a$</td> <td>Crack can't exceed the half of SP width.</td> <td>$1/2 t < Z \leq 2 t$</td> </tr> </tbody> </table>	X	Y	Z	$\leq 1/5 a$	Crack can't enter viewing area	$Z \leq 1/2 t$	$\leq 1/5 a$	Crack can't exceed the half of SP width.	$1/2 t < Z \leq 2 t$				
		X	Y	Z											
$\leq 1/5 a$	Crack can't enter viewing area	$Z \leq 1/2 t$													
$\leq 1/5 a$	Crack can't exceed the half of SP width.	$1/2 t < Z \leq 2 t$													
		<p>8.2 Protrusion over terminal :</p> <p>8.2.1 Chip on electrode pad :</p>  <table border="1" data-bbox="561 1691 1343 1870"> <thead> <tr> <th></th> <th>X</th> <th>Y</th> <th>Z</th> </tr> </thead> <tbody> <tr> <td>Front</td> <td>$\leq a$</td> <td>$\leq 1/2 W$</td> <td>$\leq t$</td> </tr> <tr> <td>Back</td> <td>$\leq a$</td> <td>$\leq W$</td> <td>$\leq 1/2 t$</td> </tr> </tbody> </table>		X	Y	Z	Front	$\leq a$	$\leq 1/2 W$	$\leq t$	Back	$\leq a$	$\leq W$	$\leq 1/2 t$	Minor
	X	Y	Z												
Front	$\leq a$	$\leq 1/2 W$	$\leq t$												
Back	$\leq a$	$\leq W$	$\leq 1/2 t$												

◆ Specification For TFT-LCD Module 3.5" -10" :

(Ver.B01)

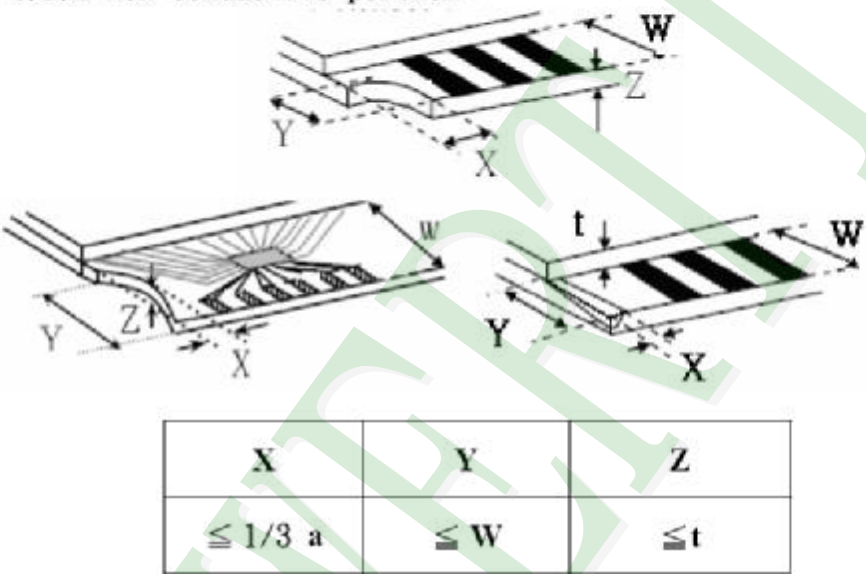
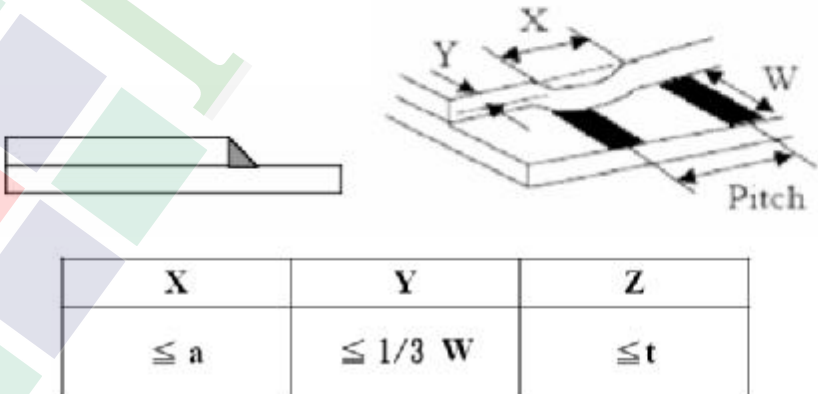
NO	Item	Criterion	Level
08	The crack of glass	<p>Symbols :</p> <p>X : The length of crack Y : The width of crack. Z : The thickness of crack W : terminal length t : The thickness of glass a : LCD side length</p>	Minor
		<p>8.2.2 Non-conductive portion :</p>  <p>⊙ If the chipped area touches the ITO terminal, over 2/3 of the ITO must remain and be inspected according to electrode terminal specifications.</p> <p>8.2.3 Glass remain :</p> 	

◆Specification For TFT-LCD Module 3.5" ~10" :

(Ver.B01)

NO	Item	Criterion	Level
09	Backlight elements	9. 1 Backlight can't work normally.	Major
		9. 2 Backlight doesn't light or color is wrong.	Major
		9. 3 Illumination source flickers when lit.	Major
10	General appearance	10. 1 Pin type 、 quantity 、 dimension must match type in structure diagram.	Major
		10. 2 No short circuits in components on PCB or FPC .	Major
		10. 3 Parts on PCB or FPC must be the same as on the production characteristic chart .There should be no wrong parts , missing parts or excess parts.	Major
		10. 4 Product packaging must the same as specified on packaging specification sheet.	Minor
		10. 5 The folding and pceled off in polarizer are not acceptable.	Minor
		10. 6 The PCB or FPC between B/L assembled distance(PCB or FPC) is ≤ 1.5 mm.	Minor

4. RELIABILITY TEST

4.1 Reliability Test Condition

(Ver.B01)

NO.	TEST ITEM	TEST CONDITION										
1	High Temperature Storage Test	Keep in $+80 \pm 2^{\circ}\text{C}$ 96 hrs Surrounding temperature, then storage at normal condition 4hrs.										
2	Low Temperature Storage Test	Keep in $-30 \pm 2^{\circ}\text{C}$ 96 hrs Surrounding temperature, then storage at normal condition 4hrs.										
3	High Temperature / High Humidity Storage Test	Keep in $+60^{\circ}\text{C}$ / 90% R.H duration for 96 hrs Surrounding temperature, then storage at normal condition 4hrs.										
4	Temperature Cycling Storage Test	$ \begin{array}{c} -30^{\circ}\text{C} \rightarrow +25^{\circ}\text{C} \rightarrow +80^{\circ}\text{C} \rightarrow +25^{\circ}\text{C} \\ (30\text{mins}) \quad (5\text{mins}) \quad (30\text{mins}) \quad (5\text{mins}) \\ \longleftarrow \hspace{10em} \longrightarrow \\ \text{10 Cycle} \end{array} $ Surrounding temperature, then storage at normal condition 4hrs.										
5	ESD Test	Air Discharge: Apply 15 KV with 10 times Discharge for each polarity +/-										
		Contact Discharge: Apply 10 V with 10 times discharge for each polarity +/-										
		1. Temperature ambience : $15^{\circ}\text{C} \sim 35^{\circ}\text{C}$ 2. Humidity relative : 30% ~ 60% 3. Energy Storage Capacitance(Cs+Cd) : $150\text{pF} \pm 10\%$ 4. Discharge Resistance(Rd) : $330\Omega \pm 10\%$ 5. Discharge, mode of operation : Single Discharge (time between successive discharges at least 1 sec) (Tolerance if the output voltage indication : $\pm 5\%$)										
6	Vibration Test (Packaged)	1. Sine wave 10~55 Hz frequency (1 min/sweep) 2. The amplitude of vibration : 1.5 mm 3. Each direction (X、Y、Z) duration for 2 Hrs										
7	Drop Test (Packaged)	<table border="1"> <thead> <tr> <th>Packing Weight (Kg)</th> <th>Drop Height (cm)</th> </tr> </thead> <tbody> <tr> <td>0 ~ 45.4</td> <td>122</td> </tr> <tr> <td>45.4 ~ 90.8</td> <td>76</td> </tr> <tr> <td>90.8 ~ 454</td> <td>61</td> </tr> <tr> <td>Over 454</td> <td>46</td> </tr> </tbody> </table>	Packing Weight (Kg)	Drop Height (cm)	0 ~ 45.4	122	45.4 ~ 90.8	76	90.8 ~ 454	61	Over 454	46
		Packing Weight (Kg)	Drop Height (cm)									
0 ~ 45.4	122											
45.4 ~ 90.8	76											
90.8 ~ 454	61											
Over 454	46											
		Drop Direction : ※1 corner / 3 edges / 6 sides each 1time										

5. PRECAUTION RELATING PRODUCT HANDLING

5.1 SAFETY

- 5.1.1 If the LCD panel breaks , be careful not to get the liquid crystal to touch your skin.
- 5.1.2 If the liquid crystal touches your skin or clothes , please wash it off immediately by using soap and water.

5.2 HANDLING

- 5.2.1 Avoid any strong mechanical shock which can break the glass.
- 5.2.2 Avoid static electricity which can damage the CMOS LSI—When working with the module , be sure to ground your body and any electrical equipment you may be using.
- 5.2.3 Do not remove the panel or frame from the module.
- 5.2.4 The polarizing plate of the display is very fragile. So , please handle it very carefully, do not touch , push or rub the exposed polarizing with anything harder than an HB pencil lead (glass , tweezers , etc.)
- 5.2.5 Do not wipe the polarizing plate with a dry cloth , as it may easily scratch the surface of plate.
- 5.2.6 Do not touch the display area with bare hands , this will stain the display area.
- 5.2.7 Do not use ketonics solvent & aromatic solvent. Use with a soft cloth soaked with a cleaning naphtha solvent.
- 5.2.8 To control temperature and time of soldering is $320 \pm 10^{\circ}\text{C}$ and 3-5 sec.
- 5.2.9 To avoid liquid (include organic solvent) stained on LCM

5.3 STORAGE

- 5.3.1 Store the panel or module in a dark place where the temperature is $25^{\circ}\text{C} \pm 5^{\circ}\text{C}$ and the humidity is below 65% RH.
- 5.3.2 Do not place the module near organics solvents or corrosive gases.
- 5.3.3 Do not crush , shake , or jolt the module.

5.4 TERMS OF WARRANTY

- 5.4.1 Applicable warrant period
The period is within thirteen months since the date of shipping out under normal using and storage conditions.
- 5.4.2 Unaccepted responsibility
This product has been manufactured to your company's specification as a part for use in your company's general electronic products. It is guaranteed to perform according to delivery specifications. For any other use apart from general electronic equipment, we cannot take responsibility if the product is used in nuclear power control equipment, aerospace equipment , fire and security systems or any other applications in which there is a direct risk to human life and where extremely high levels of reliability are required.

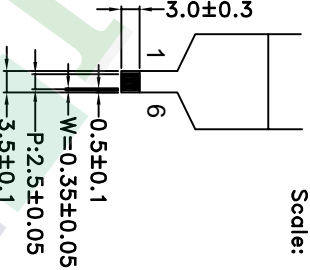
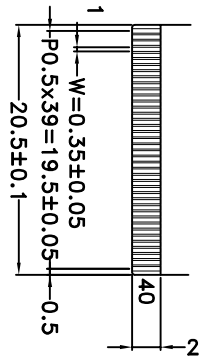
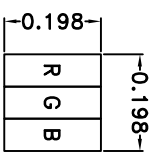
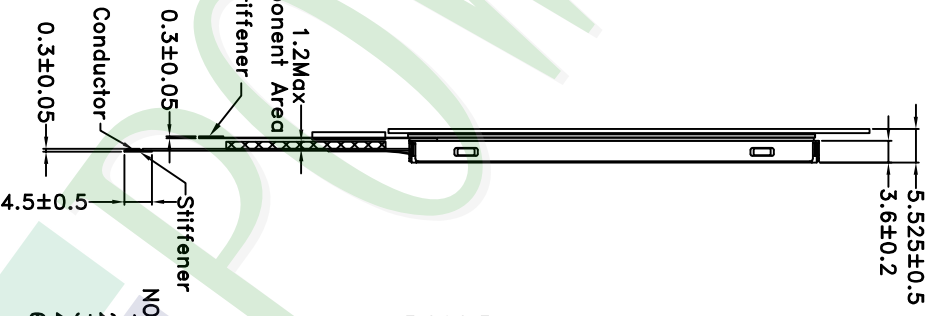
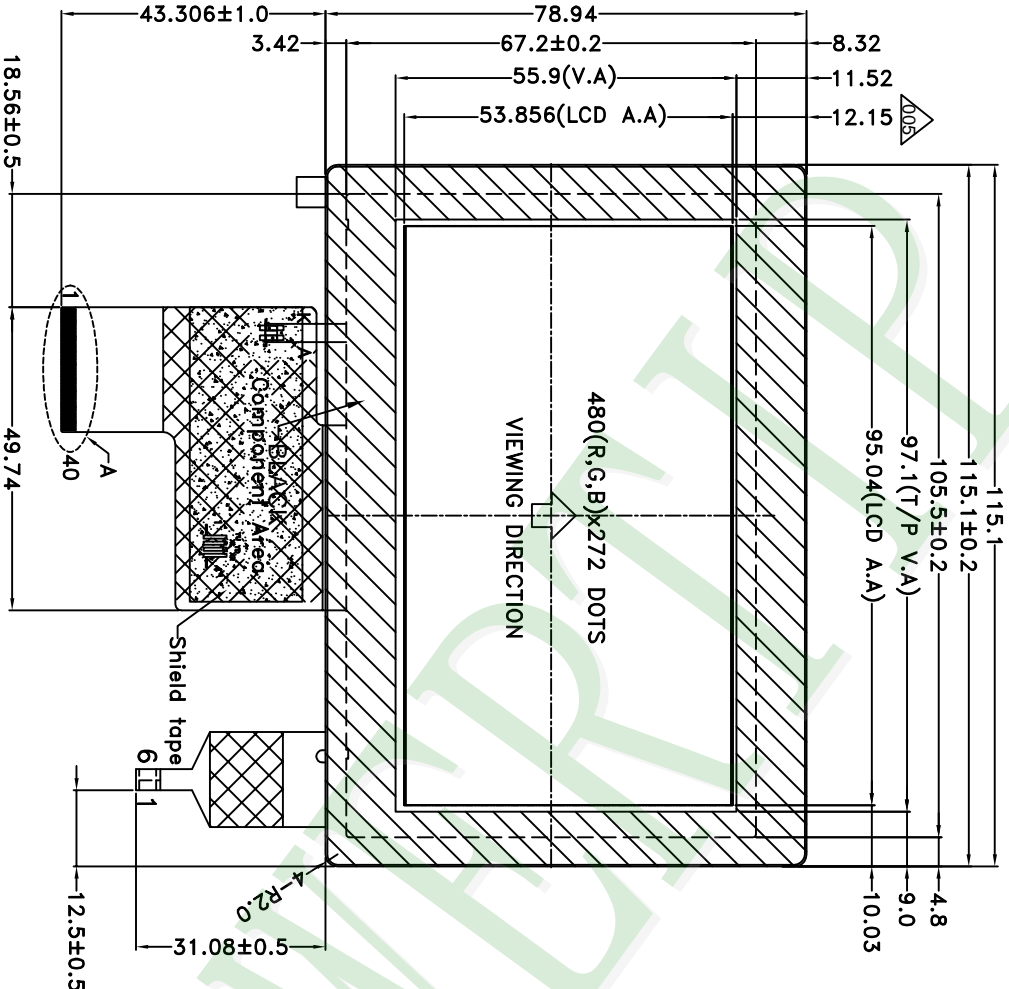

No	Pin Name	Description
1	GND	Ground
2	SDA	I2C Data
3	SCL	I2C Clock
4	VDD	3.3V45%
5	INT	active_Low
6	XRES	XRES

NOTES:

- TYPE: a-Si TFT
- LCD DISPLAY: POSITIVE/TRANSMISSIVE
- VIEW DIRECTION: 6 O'CLOCK
- The tolerance unless classified ±0.3mm
- FPC suggested connector :
- 08 6262 040 340 846+(KYOCERA) or compatible
- Component Area & Unbending Area

007																																	
006	MODIFY AA	Air	2016/09/01	PH4802721T009-IBF01	<p>久正光电股份有限公司 POWERIP TECHNOLOGY CORPORATION</p>	Design	Air	<table border="1"> <thead> <tr> <th>Unit</th> <th>MM</th> <th>Material</th> <th>Thickness</th> <th>Quantity</th> </tr> </thead> <tbody> <tr> <td>1</td> <td>~</td> <td>4</td> <td>~</td> <td>16</td> </tr> <tr> <td>16</td> <td>~</td> <td>63</td> <td>~</td> <td>250</td> </tr> <tr> <td>63</td> <td>~</td> <td>250</td> <td>~</td> <td>-</td> </tr> <tr> <td>250</td> <td>~</td> <td>1000</td> <td>~</td> <td>-</td> </tr> </tbody> </table>	Unit	MM	Material	Thickness	Quantity	1	~	4	~	16	16	~	63	~	250	63	~	250	~	-	250	~	1000	~	-
Unit	MM	Material	Thickness	Quantity																													
1	~	4	~	16																													
16	~	63	~	250																													
63	~	250	~	-																													
250	~	1000	~	-																													
005	CHANGE T/P	Air	2016/07/01	JLMD-PH4802721T009-IBF01	Check	Terry																											
004	MODIFY TOLERANCE	Air	2016/05/24		Approve	Ryan																											
003	CHANGE T/P	Air	2016/03/25																														
002	NEW DRAWING	Air	2016/03/17																														
001																																	
REV																																	

1. 包裝材料規格表 (Packaging Material) : (per carton)

No.	Item	Model	Dimensions (mm)	1Pcs Weight	Quantity	Total Weight
1	成品 (LCM)	PH480272T009-IBF01	115.1X73.9X5.525	0.0781	144	11.2464
2	多層薄膜(1)POF	OTFILM0BA03ABA	19"X350X0.015	—	6	—
3	TRAY 盤 (2)Tray	TY00000000381	352 X 260 X 13.5	0.1	42	4.2
4	內盒(3)Product Box	BX36627063ABBA	383 X 270 X 66	0.182	6	1.092
5	保利龍板(4)Polylon board	OTPLB00PL08ABA	550 X 393 X 20	0.0284	2	0.0568
6	外紙箱(5)Carton	BX57041027CCBA	570 X 410 X 265	1.0	1	1.0
7						
8						
9						

2. 一整箱總重量 (Total LCD Weight in carton) : 17.60 Kg±10%

3. 單箱數量規格表 (Packaging Specifications and Quantity) :

(1) LCM quantity per box : no per tray 4 x no of tray 6 = 24

(2) Total LCM quantity in carton : quantity per box 24 x no of boxes 6 = 144

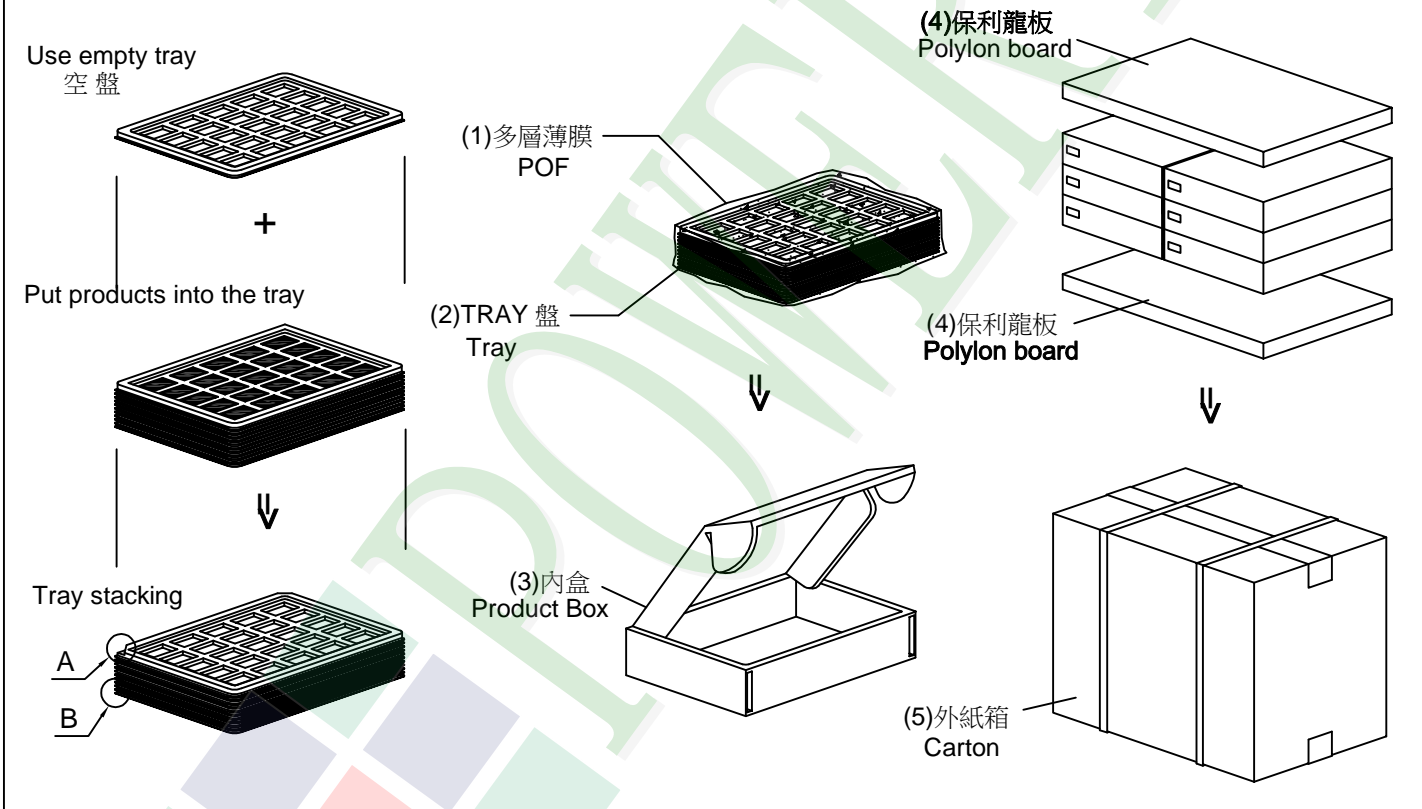

特 記 事 項 (REMARK)

