

# TWN4 Mini EVP SE M HF

Single-frequency RFID module (HF/NFC) for external antenna

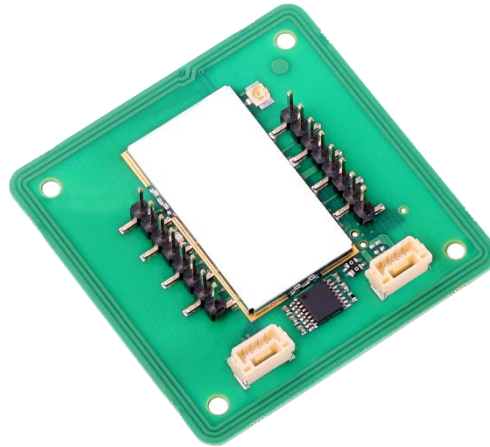

TWN4 Mini EVP SE M HF  
(exemplary illustration)

The RFID modules of the TWN4 Mini reader family have been designed for integration into machines, handheld computers or any other device where small size matters. Thanks to their compact dimensions, the modules can be directly integrated into almost any host system. The host communication takes place via RS-232 or asynchronous serial TTL interface. Besides, the new EVP modules offer two LEDs that can be controlled per software. For applications requiring additional security, an external Secure Access Module (SAM) can be connected.

Key features of the TWN4 Mini EVP SE M HF reader module include enhanced HF performance, a powerful SDK for writing apps that are executed directly on the module, the possibility to upgrade the firmware in the field, transparent data exchange with the RFID media, and compact dimensions that enable a module integration even into smaller systems or devices, like PC boards. Additionally, the module can read a lot of HF RFID technologies from the 13.56 MHz frequency band, including NFC. This gives the option to select as many of the technologies required instead of being forced to select just a few ones.

## Special features:

- + Possibility to read many HF RFID technologies
- + Enhanced HF performance
- + Equipped with a connector for external HF antenna (13.56 MHz)
- + External RFID antenna granting module certifications optionally available
- + Powerful SDK for writing apps which are executed directly on the module
- + Firmware update in the field possible
- + Pin compatible with existing TWN4 MultiTech HF Mini reader modules
- + Supports transparent data exchange with RFID media
- + Development board for interface testing available on request



Elevator



EV Chargers



Access



Shop POS



Fitness  
Equipment



Ticket POS



PC Log-on



Document  
Management



Driver ID



Vending



Parking



Gaming



Locker Locks



Time  
Attendance



Industrial  
PC

## TECHNICAL DATA

FREQUENCY	13.56 MHz (HF)
ANTENNA	Externally, 50 Ohm for 13.56 MHz
DIMENSIONS (L X W X H)	Approx. 50.00 x 50.00 x 12.00 mm / 1.97 x 1.97 x 0.47 inch
POWER	3.15 – 5.5 V DC ES1/PS2 classified power source according to IEC 62368-1, short-circuit current < 8 A
CURRENT CONSUMPTION	RF field on: approx. 180 mA typically
TEMPERATURE RANGE	Operating: -25 °C up to +80 °C (-13 °F up to +176 °F) Storage: -40 °C up to +85 °C (-40 °F up to +185 °F)
RELATIVE HUMIDITY	5% to 95% non-condensing
READ/WRITE DISTANCE	Up to 100 mm / 3.94 inch, depending on environment and transponder
MTBF	500,000 hours
WEIGHT	Approx. 12 g / 0.42 oz
SUPPORTED OPTIONS AND TRANSPONDERS	Depending on the firmware version and installed options, ELATEC readers and modules can support a wide range of RFID technologies. Please refer to the relevant ELATEC transponder matrix (available at <a href="http://www.elatec-rfid.com/int/transponder-technology">www.elatec-rfid.com/int/transponder-technology</a> ) for more information about the available options and RFID technologies supported by the product.
OS SUPPORT	Windows 7 (32-/64-bit) and higher versions, Linux, MAC OS X <sup>1)</sup>
PERIPHERAL INTERFACES	RS-232, TTL serial (logic level 3.3 V, CMOS, 5 V tolerant), SPI <sup>1)</sup> , 4 GPIOs, Clock/Data, Wiegand D0/D1, USB <sup>1)</sup>
SIGNALING	1 red LED, 1 green LED, both controlled by software
TRANSMISSION SPEED	RS-232/TTL serial: up to 115,200 baud, HF Air: up to 848 kbit/s, Host: USB full speed (12 Mbit/s) <sup>1)</sup>
CERTIFICATION NAME	TWN4 Mini EVP SE M HF
CERTIFICATIONS	Non-exhaustive list <sup>2)</sup> : CE/RED, FCC, IC, TAA compliant, REACH and RoHS-III compliant
ORDER CODES	T4MP-FE3D1X2      Standard reader module (TTL serial) Development board available on request.

<sup>1)</sup>On request

<sup>2)</sup>Please note that TWN4 Mini EVP SE M HF has been tested with an external printed circuit board equipped with a specific RFID HF antenna (refer to the user manual for more information). This specific antenna can be ordered with TWN4 Mini EVP SE M HF as part of a kit (refer to "Accessories"). The use of TWN4 Mini EVP SE M HF with another antenna is not part of the approvals granted to the product. In case TWN4 Mini EVP SE M HF is used with another antenna, a separate approval, additional testing or new authorization for a use with this specific antenna is required. Contact ELATEC for more information.

## ACCESSORIES

CABLES	CAB-J4MSR9MSB150	Cable, JST MS/RS-232 MS, black, 1.5 m
	CAB-L3	UMCC cable, 500 mm
EXTERNAL ANTENNA	ANT-M01C12	TWN4 Mini EVP antenna, HF only, 43 x 40 mm (antenna board dimensions)

## TECHNICAL DRAWINGS

X2	
Pin	Function
1	SAM1_RST
2	SAM1_CLK
3	IO0_TDO
4	IO1_TRST
5	IO2
6	IO3
7	SAM1_IO
8	VCC

X4 [RS232]	
Pin	Function
1	GND
2	RX_V24
3	TX_V24
4	VCC +5V

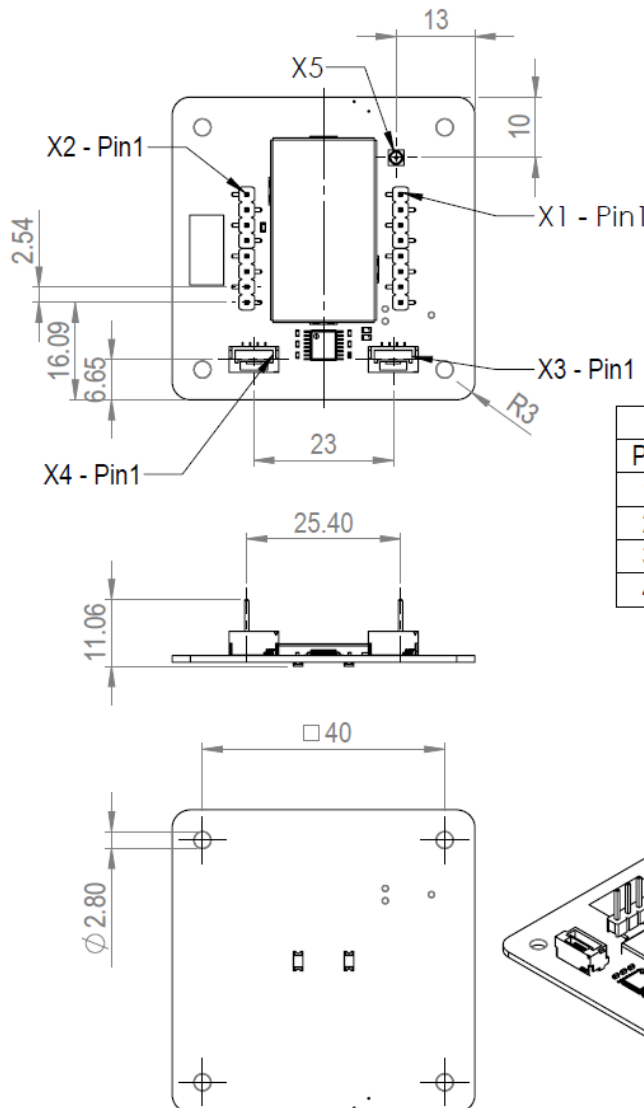

X1	
Pin	Function
1	Reset
2	PWRDWN
3	GND
4	VCC +5V
5	RX_MOSI_SD_DP_F
6	TX_MISO_SCL_DM_F
7	SCK_USBVBUS
8	SS_USBD

X3 [TTL/USB]	
Pin	Function
1	GND
2	RX_MOSI_SDA_DP
3	TX_MISO_SCL_DM
4	VCC +5V

Pin spacing 2.54 mm [0.1 inch]

### HQ / EUROPE

ELATEC GmbH  
 Zeppelinstraße 1  
 82178 Puchheim, Germany  
 P +49 89 552 9961 0  
 F +49 89 552 9961 129  
 info-rfid@elatec.com

### AMERICAS

ELATEC Inc.  
 1995 SW Martin Hwy.  
 Palm City, FL 34990, USA  
 P +1 772 210 2263  
 F +1 772 382 3749  
 americas-info@elatec.com

### APAC

ELATEC Singapore  
 1 Scotts Road #21-10 Shaw  
 Centre, Singapore 228208  
 P +65 9670 4348  
 apac-info@elatec.com

### MIDDLE EAST

ELATEC Middle East  
 Trading FZE  
 P.O. Box 16868, Dubai, UAE  
 P +971 50 9322691  
 middle-east-info@elatec.com

[elatec.com](http://elatec.com)

ELATEC reserves the right to change any information or data in this document without prior notice. ELATEC declines all responsibility for the use of this product with any other specification but the one mentioned above. Any additional requirement for a specific customer application has to be validated by the customer themselves at their own responsibility. Where application information is given, it is only advisory and does not form part of the specification. Disclaimer: All names used in this document are registered trademarks of their respective owners.