

# TWN4 MultiTech 3 M

Multi-frequency RFID module (LF/HF) with NFC and BLE support

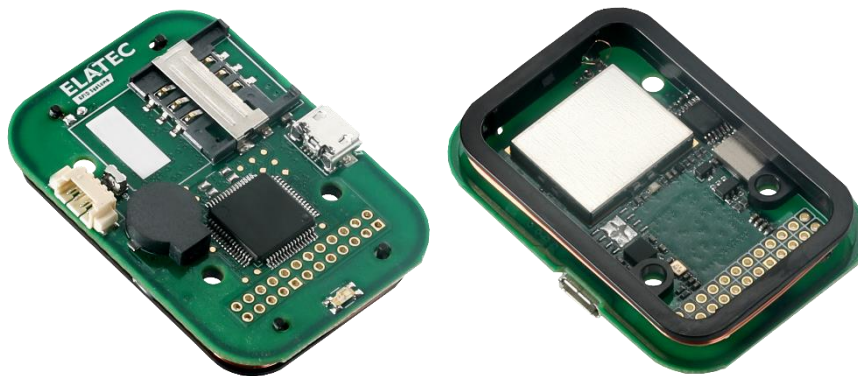

TWN4 MultiTech 3 M  
(exemplary illustrations\*)

\*Product images may show product variants or additional components that are not available.

The powerful reader modules of the ELATEC TWN4 MultiTech 3 family combine a compact form factor with optimized read/write performance. All devices integrate RFID (125 kHz and 13.56 MHz), NFC and, optionally, Bluetooth Low Energy (BLE) capabilities. Thanks to their reduced size, the modules can be easily used for almost all applications where small size and full performance matter. Furthermore, they are compatible with the most common host interfaces, such as USB, and they can also be configured with different connector options.

TWN4 MultiTech 3 M key features include a powerful SDK for writing apps that are executed directly on the module, the possibility to upgrade the firmware in the field, transparent data exchange with the RFID media, and a powerful BLE module. Additionally, the module can read more than 60 RFID technologies from low (LF) and high frequency (HF) bands, including NFC. This gives the option to select as many of the technologies required instead of being forced to select just a few ones.

Special features:

- + Possibility to read more than 60 RFID technologies
- + Two RFID frequencies (125 kHz/13.56 MHz), NFC and BLE
- + Optionally available with a 24-pin header, further configurations available
- + Powerful SDK for writing apps which are executed directly on the module
- + Firmware update in the field possible
- + On-board 18 kB flash storage, e.g. for storing user accessible non-volatile data
- + Supports transparent data exchange with RFID media
- + CCID and PC/SC 2.01
- + Optimized read/write performance combined with a compact form factor



## TECHNICAL DATA

FREQUENCIES	125 kHz (LF) / 13.56 MHz (HF) / 2.4 GHz (BLE)
ANTENNAS	Integrated
DIMENSIONS (L X W X H)	<p><u>C0 hardware configuration:</u> Approx. 50.00 x 35.00 x 9.50 mm, maximum diameter &lt; 55.00 mm Approx. 1.97 x 1.38 x 0.37 inch, maximum diameter &lt; 2.17 inch</p> <p><u>C1 hardware configuration:</u> Approx. 50.00 x 35.00 x 16.00 mm, maximum diameter &lt; 55.00 mm Approx. 1.97 x 1.38 x 0.63 inch, maximum diameter &lt; 2.17 inch</p> <p><u>C2 hardware configuration:</u> Approx. 50.00 x 35.00 x 12.31 mm, maximum diameter &lt; 55.00 mm Approx. 1.97 x 1.38 x 0.48 inch, maximum diameter &lt; 2.17 inch</p> <p>Refer to the technical drawings below for further information.</p>
POWER	<p>Micro USB (X1): 4.3 V - 5.5 V Generic interface (X2): 3.3 V (pin 19) or 4.3 V - 5.5 V (pin 13) UART (X3): 5 V ES1/PS2 classified power source according to IEC 62368-1, short-circuit current &lt; 8 A</p>
CURRENT CONSUMPTION	RF field on: 120 mA typically + 16 mA (BLE) / Sleep: 500 µA typ.
TEMPERATURE RANGE	<p>Operating: -25 °C up to +80 °C (-13 °F up to +176 °F) Storage: -40 °C up to +85 °C (-40 °F up to +185 °F)</p>
RELATIVE HUMIDITY	5% to 95% non-condensing
READ/WRITE DISTANCE	<p>LF and HF: up to 100 mm / 4 inch, depending on environment and transponder BLE: up to several meters/feet</p>
OPERATING MODES (USB)	USB keyboard emulation – USB virtual COM port – CCID / PC/SC 2.01
BLUETOOTH LOW ENERGY	BLE version 4.1 (upgradable to 4.2)
MTBF	500,000 hours
WEIGHT	Approx. 10 g / 0.35 oz
SUPPORTED OPTIONS AND TRANSPONDERS	Depending on the firmware version and installed options, ELATEC readers and modules can support a wide range of RFID technologies. Please refer to the relevant ELATEC transponder matrix (available at <a href="http://www.elatec-rfid.com/int/transponder-technology">www.elatec-rfid.com/int/transponder-technology</a> ) for more information about the available options and RFID technologies supported by the product.
OS SUPPORT	Windows 7 (32-/64-bit) and higher versions, Linux, Android <sup>1)</sup> , iOS <sup>1)</sup> , MAC OS X <sup>1)</sup>
PERIPHERAL INTERFACES	<p>1 SAM slot (ID-000 card format) X1: micro USB, female X2: generic interface (refer to pin assignment in technical drawings below for more information about the available interfaces) X3: UART connector header 4 pos., 1.25 mm pitch, surface mount, right-angle In the C1 and C2 hardware configurations, the reader modules are equipped with a 24-pin header (no pin header available with the C0 hardware configuration).</p>
SIGNALING	<p>1 two-color LED (red/green) Acoustic loudspeaker</p>
TRANSMISSION SPEED	Host: USB Full speed (12 Mbit/s), RS-232: up to 115,200 baud, HF Air: up to 848 kbit/s, BLE Air: up to 100 kbit/s
CERTIFICATION NAME	TWN4 MultiTech 3 M
CERTIFICATIONS	<p>Non-exhaustive list<sup>2)</sup>: CE/RED, FCC, IC, TAA compliant, REACH and RoHS-III compliant</p>

<sup>1)</sup>On request

<sup>2)</sup>The product has been certified for use in many countries and regions. Contact your Sales representative for detailed information about all certifications and approvals granted to the product.

ORDER CODES	<b>C0 hardware configuration</b>	
	T430-F7C0	Reader module in standard configuration
	T430-F7C0-P	Reader module with P option
	T430-F7C0-PI	Reader module with PI options
	<b>C1 hardware configuration</b>	
	T430-F7C1	Reader module in standard configuration
	T430-F7C1-P	Reader module with P option
	T430-F7C1-PI	Reader module with PI options
	<b>C2 hardware configuration</b>	
	T430-F7C2	Reader module in standard configuration
	T430-F7C2-P	Reader module with P option
	T430-F7C2-PI	Reader module with PI options

## ACCESSORIES

CABLES	ELATEC RFID modules can be delivered with additional cables. Refer to the data sheet <i>Cables for ELATEC devices</i> for detailed information.
--------	---

## TECHNICAL DRAWINGS

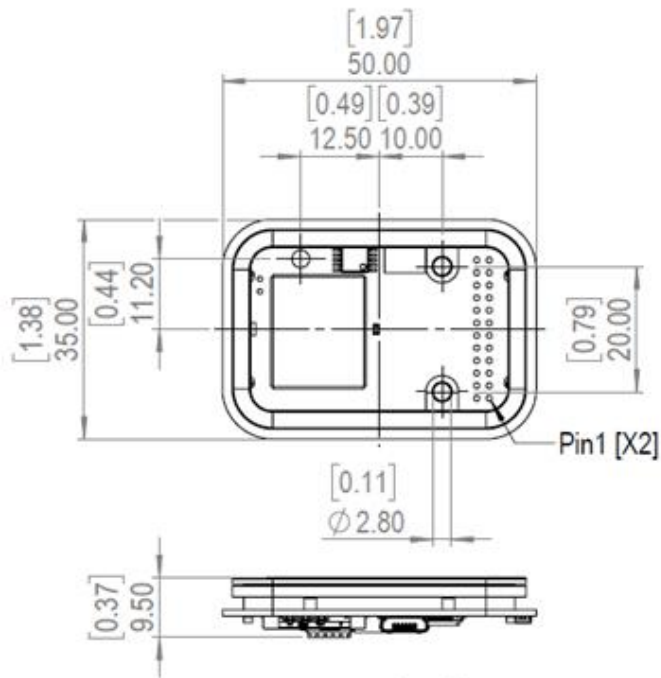

X2			
	Pin		
RESET	24	23	PWRDWN-
GPIO6	22	21	GPIO5
GPIO4	20	19	VCC
COM1_RX	18	17	COM1_TX
USB_DP_P	16	15	UGND
USB_DM_P	14	13	UVCC
GND	12	11	V24_RXD
HOSTENSE	10	9	V24_TXD
SPI_SCK	8	7	SPI_SS-
SPI_MISO	6	5	SPI_MOSI
I2C_SDA	4	3	I2C_SCI
CAN_RX	2	1	CAN_TX

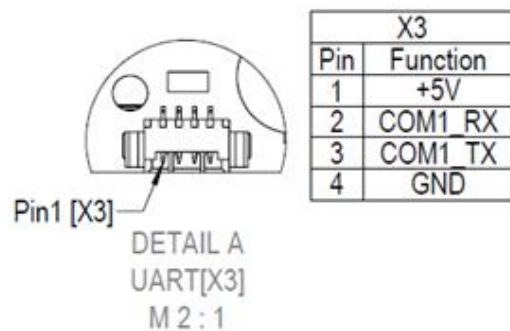
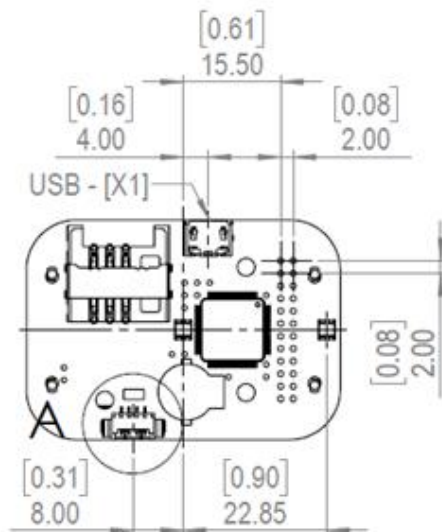

CO hardware configuration

All measures in mm [inch]

## TECHNICAL DRAWINGS

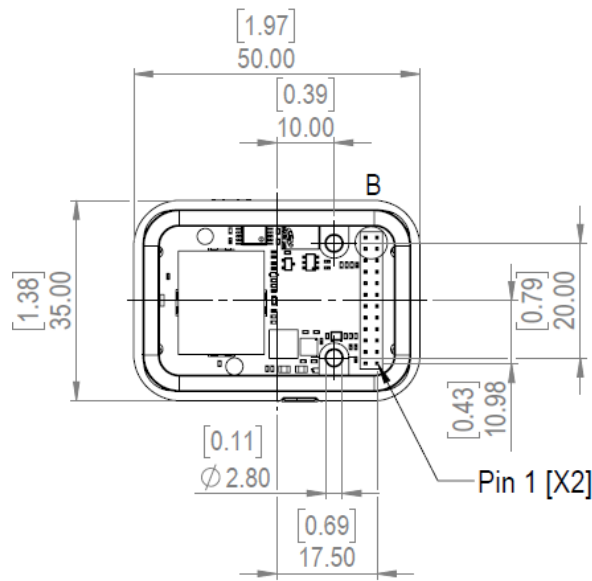

X2			
	Pin		
RESET	24	23	PWRDWN-
GPIO6	22	21	GPIO5
GPIO4	20	19	VCC
COM1_RX	18	17	COM1_TX
USB_DP_P	16	15	UGND
USB_DM_P	14	13	UVCC
GND	12	11	V24_RXD
HOSTENSE	10	9	V24_TXD
SPI_SCK	8	7	SPI_SS-
SPI_MISO	6	5	SPI_MOSI
I2C_SDA	4	3	I2C_SCI
CAN_RX	2	1	CAN_TX

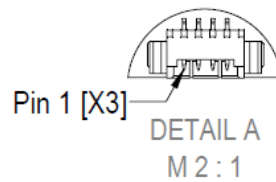
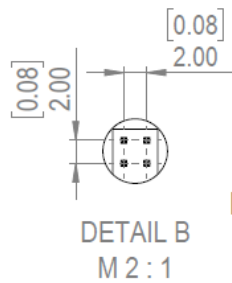
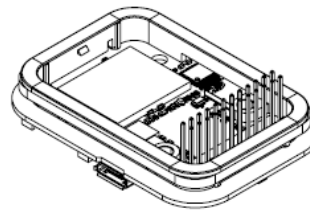
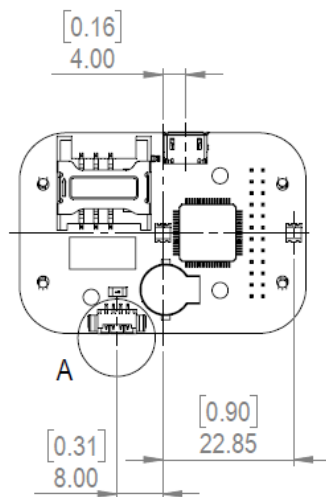
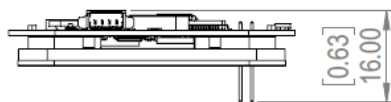

X3	
Pin	Function
1	+5V
2	COM1_RX
3	COM1_TX
4	GND

C1 hardware configuration

All measures in mm [inch]

## TECHNICAL DRAWINGS

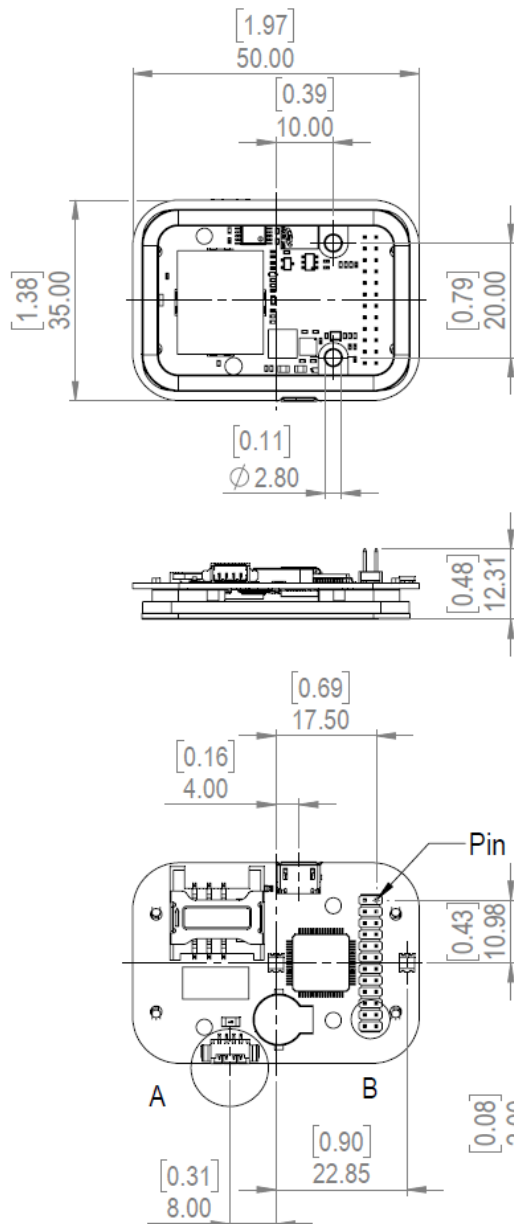

X2		Pin	
RESET	24	23	PWRDWN-
GPIO6	22	21	GPIO5
GPIO4	20	19	VCC
COM1_RX	18	17	COM1_TX
USB_DP_P	16	15	UGND
USB_DM_P	14	13	UVCC
GND	12	11	V24_RXD
HOSTENSE	10	9	V24_TXD
SPI_SCK	8	7	SPI_SS-
SPI_MISO	6	5	SPI_MOSI
I2C_SDA	4	3	I2C_SCI
CAN_RX	2	1	CAN_TX

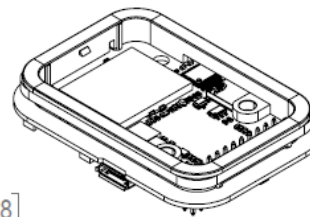

X3		Pin	Function
1			+5V
2			COM1_RX
3			COM1_TX
4			GND

C2 hardware configuration

All measures in mm [inch]

### HQ / EUROPE

ELATEC GmbH  
Zeppelinstraße 1  
82178 Puchheim, Germany  
P +49 89 552 9961 0  
F +49 89 552 9961 129  
info-rfid@elatec.com

### AMERICAS

ELATEC Inc.  
1995 SW Martin Hwy.  
Palm City, FL 34990, USA  
P +1 772 210 2263  
F +1 772 382 3749  
americas-info@elatec.com

### APAC

ELATEC Singapore  
1 Scotts Road #21-10 Shaw  
Centre, Singapore 228208  
P +65 9670 4348  
apac-info@elatec.com

### MIDDLE EAST

ELATEC Middle East  
Trading FZE  
P.O. Box 16868, Dubai, UAE  
P +971 50 9322691  
middle-east-info@elatec.com

[elatec.com](http://elatec.com)

ELATEC reserves the right to change any information or data in this document without prior notice. ELATEC declines all responsibility for the use of this product with any other specification but the one mentioned above. Any additional requirement for a specific customer application has to be validated by the customer themselves at their own responsibility. Where application information is given, it is only advisory and does not form part of the specification. Disclaimer: All names used in this document are registered trademarks of their respective owners.