

SIGNAL CONDITIONING

Op. Amplifier
LM358
LM324

Comparator
LM393
LM339

TVS (ESD PROTECTION)

Bidirectional TVS Diode
HTSD03~36C (SOD PKG)

POWER MANAGEMENT

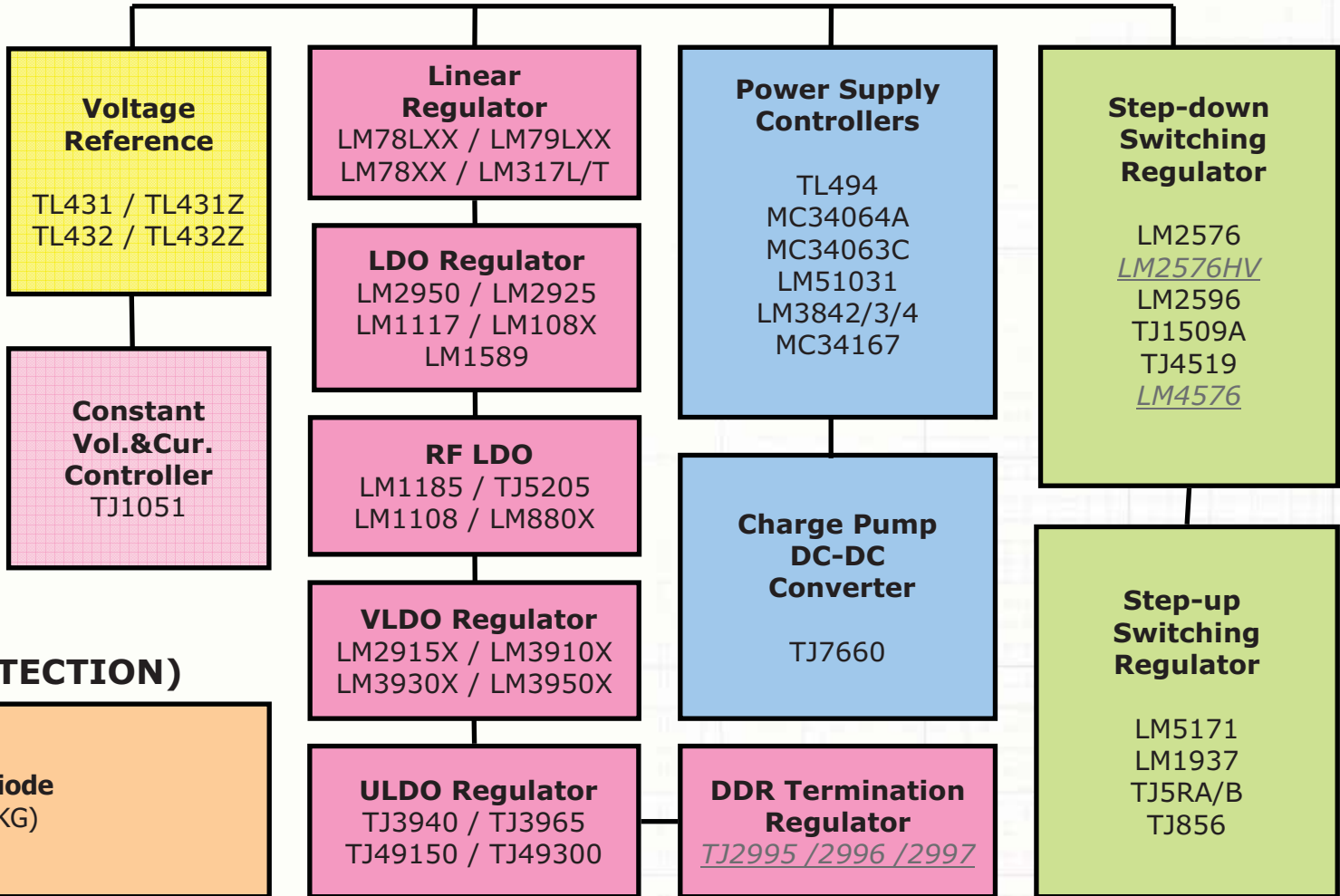

PRODUCT LINEUP

DO NOT MAKE COPY

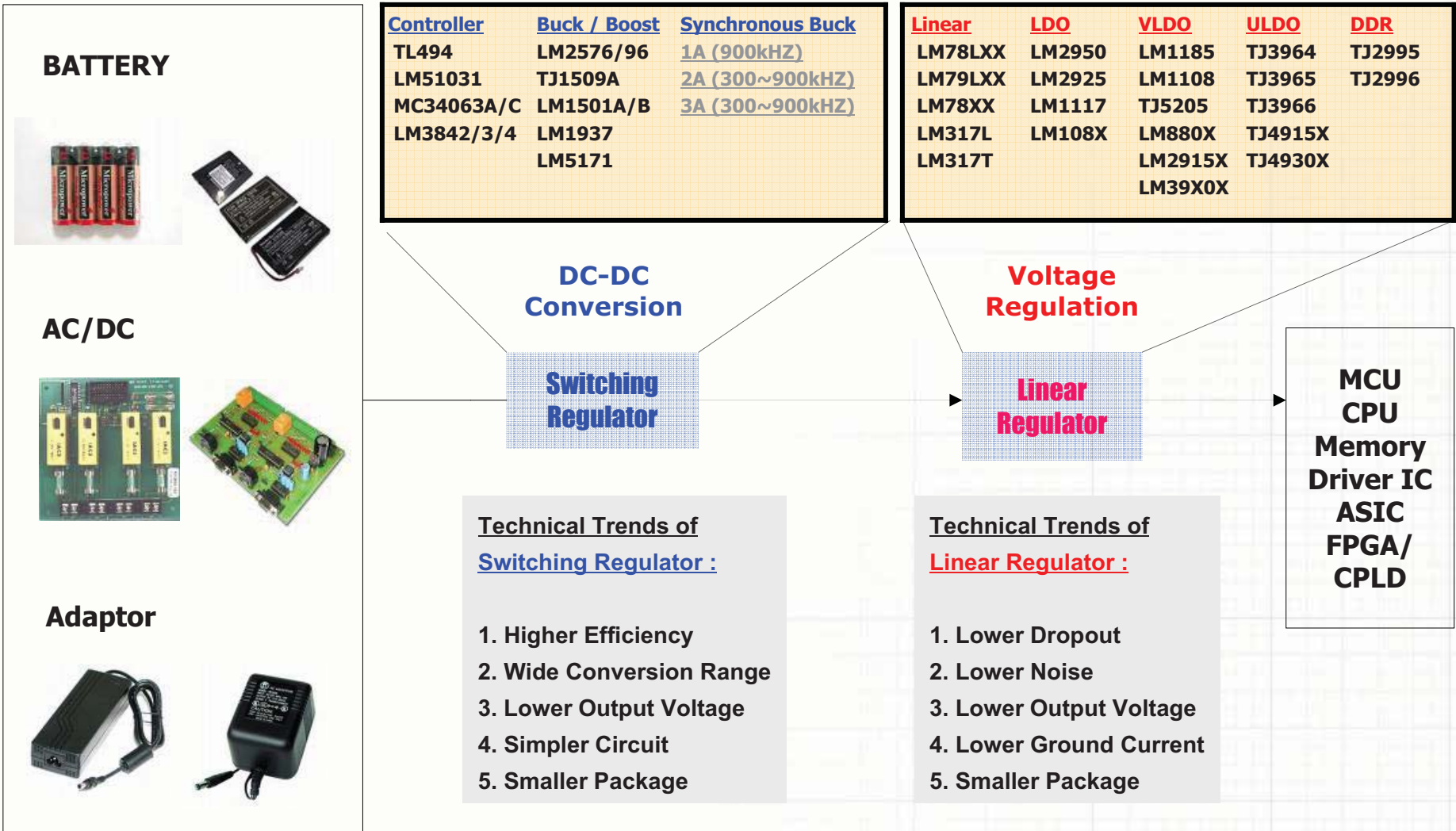

LINEAR REGULATORS

DO NOT MAKE COPY

MAX OUTPUT CURRENT (mA)

5000mA

LM1084

LM3950X

3000mA

LM1085 LM1589

LM3930X

TJ49300
(Low Vol)

TJ3202

1500mA

LM78XX

LM1086

LM2915X

TJ3965

TJ49150
(Low Vol)

TJ2995
TJ2996

1000mA

LM1117

LM3910X

TJ2997

500mA/

LM8805

300mA/

LM317L

LM2925

LM1108

LM8801

100mA

LM78LXX

LM2950

TJ5205

LM1185

2V-Dropout

LDO

RF LDO

VLDO

ULDO

Low Vol
ULDO

Application
Specific

SWITCHING REGULATORS

DO NOT MAKE COPY

MAX OUTPUT CURRENT (mA)

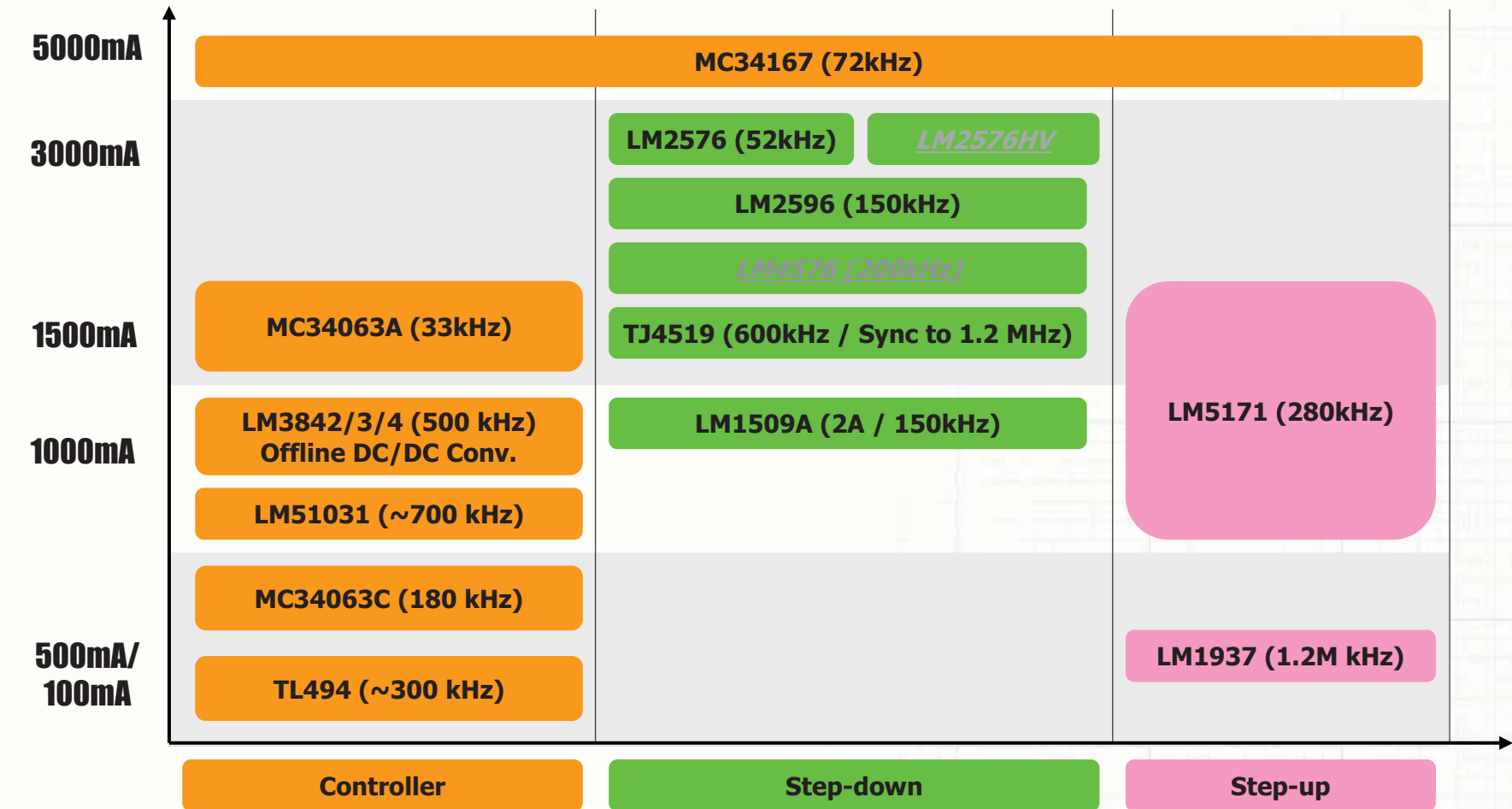

PRODUCT ROADMAP

DO NOT MAKE COPY

